

Sołtys, Jacek

**Conference Paper**

## Spatial conditions for development of activation of peripheral areas: the case of northern Poland

52nd Congress of the European Regional Science Association: "Regions in Motion - Breaking the Path", 21-25 August 2012, Bratislava, Slovakia

**Provided in Cooperation with:**

European Regional Science Association (ERSA)

*Suggested Citation:* Sołtys, Jacek (2012) : Spatial conditions for development of activation of peripheral areas: the case of northern Poland, 52nd Congress of the European Regional Science Association: "Regions in Motion - Breaking the Path", 21-25 August 2012, Bratislava, Slovakia, European Regional Science Association (ERSA), Louvain-la-Neuve

This Version is available at:

<https://hdl.handle.net/10419/120753>

**Standard-Nutzungsbedingungen:**

Die Dokumente auf EconStor dürfen zu eigenen wissenschaftlichen Zwecken und zum Privatgebrauch gespeichert und kopiert werden.

Sie dürfen die Dokumente nicht für öffentliche oder kommerzielle Zwecke vervielfältigen, öffentlich ausstellen, öffentlich zugänglich machen, vertreiben oder anderweitig nutzen.

Sofern die Verfasser die Dokumente unter Open-Content-Lizenzen (insbesondere CC-Lizenzen) zur Verfügung gestellt haben sollten, gelten abweichend von diesen Nutzungsbedingungen die in der dort genannten Lizenz gewährten Nutzungsrechte.

**Terms of use:**

*Documents in EconStor may be saved and copied for your personal and scholarly purposes.*

*You are not to copy documents for public or commercial purposes, to exhibit the documents publicly, to make them publicly available on the internet, or to distribute or otherwise use the documents in public.*

*If the documents have been made available under an Open Content Licence (especially Creative Commons Licences), you may exercise further usage rights as specified in the indicated licence.*

# SPATIAL CONDITION OF ACTIVATION OF PERIPHERAL AREAS – THE CASE OF NORTHERN POLAND

**Jacek Soltys**

Gdansk University of Technology, Faculty of Architecture,

Department of Urban and Regional Planning

jacek.soltys@gmail.com

## **Abstract**

The areas located outside metropolitan areas and also outside areas activated through other big cities are called peripheries. There are big differences between the levels of development of metropolitan and peripheral areas in Poland. There are also great differences in opportunities for development including the location of new investment. Peripheral areas are characterized by features such as: high unemployment, relatively impoverished populations, low productivity, low territorial accessibility, and little development potential. A lack of development factors is the cause of low development level.

Peripheral areas are differential. The author analyses this differentiation, including location of development factors in peripheral areas of northern Poland. Touristic values are such a factor, but tourism is mainly seasonal. The tourist season is short, 2-4 months. The development of this tourism increases the income of people and business, but the increase of permanent workplaces is small. The lack of robust businesses that are able to start constant and stable development is one of the main weaknesses of peripheral areas. Bad transport accessibility is another weakness of peripheral areas. Spatial structure, including the settlement network is one of the factors of socio-economic development considered by the author. In some areas the lack of an appropriately big node could be the weakness of such a network.

Analysis of the case study area is conducted on the basis of the features of poviats (counties), which are described by the following indicators: employees in the industry sector and market service sector per 1000 population of working age, number of entities in national economy between 10-49 and more than 49 workers per 1000 population of working age, investment outlays in enterprises per capita in the years 2008-2010, gross value of fixed assets in enterprises per capita, average monthly gross wages and salaries, unemployment rate, and population of the biggest settlement node. The author researches correlation between the features presented above. In the next part of the paper the author performs a typology of counties. In the last part of the paper regional policy for stimulating growth is proposed.

**Keywords:** peripheral areas, development factors, regional policy, typology, daily urban system

**JEL codes:** E24, O16, R11, R23, R58

## **Introduction**

A common phenomenon is the big difference in levels of development, especially between metropolitan areas and areas beyond, called peripheries. After a slight decrease, these differences are deepening in Poland.

Peripheral areas are characterized by features such as: high unemployment, migrations, relatively impoverished local populations, low productivity and territorial accessibility (Krajowa, 2009). The result is little development potential in peripheral areas as they are limited by these realities. Eventually, they become barriers to development. To overcome these barriers external policy interventions are needed as a part of the regional policy on the national and regional levels.

The term: “peripheral area” refers to the theory of cores and peripheries (J. Friedmann). In this theory, the “cores” are the territorial social subsystems generating innovations, whereas the peripheries are the regions located outside the cores (Domański, 2005).

In this paper, the periphery is examined not only from the state point of view, but also the policy pursued by the regions (voivodeships). Development is concentrated around their capitals, "which are the important growth poles for their regional base, but need not be a pole of development at the national level" (Wojnicka, 2009). Therefore, the peripheral areas were not only space outside the metropolitan areas, but also outside the regions of voivodeship capitals, which are the “national centers for performing some of the metropolitan functions” (Konceptcja, 2011).

Regional policy should include the following paradoxical phenomenon:

- There is negative natural increase of population in big cities, which are the poles of development and growth for the demand for labor.
- Peripherals are characterized by positive natural increase of population, especially in the countryside, on the other hand, where there is a lack of jobs and economic development factors.

The logical consequence of the above should be migration from peripheral areas, especially rural to metropolitan areas. They face at least two barriers in Poland: housing and mentality – the reluctance to emigrate. There are some advantages. Excessive emigration would result in “leaching” development factors: migration of active, better educated people,

which reduces the opportunities for development of peripheral areas. Therefore, there is a need for regional development policy in these areas.

This paper presents the preliminary results of the first phase of studies conducted in the Department of Urban and Regional Planning, Faculty of Architecture, Technical University of Gdansk. The theme of the study is “Cities in the activation of peripheral areas, based on the example of the northern Polish regions”. The research subject was the diversification of the area, including the distribution of developmental factors and the spatial relationships essential to stimulate growth. The research tools were: statistical analysis, including typology.

There were included the author’s experience in work on strategic planning for many municipalities, as well as academic experience, including particular student projects and the results of questionnaires compiled by the local County Office of Labor (Powiatowy Urząd Pracy – PUP) in Kościerzyna in the Pomeranian voivodeship.

## **1. General characteristics of northern Poland**

The case study area included three voivodeships in northern Poland: Pomeranian, Varmian-Masurian and West Pomeranian. There are two metropolitan areas in these voivodeships: Gdansk (also called Tricity) and Szczecin. Olsztyn was also included – the Masurian voivodeship capital city, which did not make up the metropolitan area. Delimitation of the peripheral area was based on the author’s earlier work (Sołtys, 2011), but there are now only entire counties (poviats), therefore the study area includes counties: Gryfiński and Kamieński, and doesn’t include counties: Policki and Goleniowski.

The study area contains 8,4 % of the population of Poland and 17,7 % of its area. Gross domestic product (GDP) is known only in subregions NUTS3. There is 5,3 % Polish GDP in the area of 6 entire subregions containing 7,2 % of the Polish population (tab. 1).

The study area is mostly located in the coastline zone of the Baltic Sea, covering the area of two voivodeships: Pomeranian and West Pomeranian. Seaside location has an impact on the high tourist attraction, but there are also economic problems arising from the protection of the Baltic Sea fish stocks and fishing limits.

Table. 1

## Gross domestic product and population in subregions NUTS3

Subregion NUTS3	Gross domestic product				Popula- tion	Registered unem- ployment rate	
	Per capi- ta	Dynamics 2001 = 100	Poland=100			2010	2010
	2009		2001	2009			
Koszaliński	28058	162	85	80	591969	20,6	20,4
Stargardzki	22232	156	70	63	374565	22,6	22,6
Słupski	27616	168	81	78	480883	19,2	18,9
Starogardzki	27050	174	78	77	493131	17,1	17,9
Elbląski	24807	172	70	70	529716	19,9	20,0
Ełcki	21553	161	66	61	284051	24,5	24,4
<b>Total / average</b>	<b>25710</b>	<b>166</b>	<b>76</b>	<b>73</b>	<b>2754315</b>		

*Source: Central Statistical Office – Local Data Bank and own calculations*

The biggest area is the Lake District of Pomerania and Masuria. It is characterized by diverse land reliefs, lakes, and forests, making the location very attractive for tourism. Lands left there by the German population and settled by the Polish population after WW II are a considerable part of the researched area. Historically, state rural farms were located in these areas; however the transformation to market economy has caused their decay, leading to high unemployment in the countryside and the related problems of social dysfunction (inaction, alcoholism), as well as personal and inherited poverty. Loss of work by entire families has started decreasing the demand for the local service sector.

In the majority of the area there is no big settlement node and the distance to such a node is long. Most of the area is sparsely populated rural area with a sparse settlement pattern: less than 20 villages within 100 km<sup>2</sup> and the average size of villages is below 250 inhabitants (Koncepcja, 2011).

## 2. Factors and mechanism of the development

Analysis of the factors and conditions for development of peripheral areas should begin by analyzing the mechanisms of economic development of regions, taken into account by leading scientists. Causes of peripheral development are described, among others by Miszczuk (2010) on the basis of selected theories of regional development as described by Dawkins (2003). These theories are complementary, and explain why in some regions there

was greater development and why this development becomes fixed. Thus, exogenous growth theory indicates the importance of the development of capital inflows and labor; neoclassical exogenous growth theory suggests the role of external demand and exports; endogenous growth theory indicates the capability and resources for the use of demand, and shows the role of investment in the development of production factors and "learning" the most efficient use of these factors. It follows from theory, that the cause of regional peripheries are:

- The absence or scarcity of spatial assets for the location of external investments.
- The lack of responsiveness to external demand and production of products that can be exported. This lack may be due to lack of capital, management and marketing weakness or lack of product innovations that create new or better, cheaper, better promoted products, compared to the competitors.

In response to the variability of external conditions, including a number of risks, the companies take a new form of organization to respond to constant change through innovation. This new form is a network of cooperation, exchange of knowledge and information. However, this network usually omits the outermost regions (Miszczuk, 2010).

Theories explain the reasons and causes of peripheral development, but only slightly show how to overcome the remoteness of these areas and initiate development. As one of the few, the product cycle theory points to the opportunities for the development of peripheral areas by locating them in the production phase, when the product becomes standardized and costs can be reduced by hiring lower skilled workers. There are threats: the cessation of production when the product becomes old, or possible earlier relocation of production to a region with even lower labor costs. Peripherality should disappear according to the theory of interregional convergence. The factor price differences should decrease. But this is only the free movement of factors between regions. In fact, it is not free. In the dynamic approach it is distinguished by the relative convergence, i.e. economic growth, and absolute, concerning macroeconomic variables. Convergence of rate of growth, however, does not lead to convergence of macroeconomic variables. Moving the beneficial effects from the developed region into a peripheral area is manifested by the growth pole theory and the theory of cumulative causation. Development of peripheral regions could be caused by the development of markets for their products and the diffusion of innovation. However, these benefits are offset by a "leaching" of capital and labor from peripheral regions to the mature ones (Miszczuk, 2010).

According to the economic base theory exogenous activities are the engine of development. Endogenous activities could be developed, if demand for their products grows. Too low demand is a big barrier for the development of a sector. This is a significant issue because most local firms act in this sector and new firms also tend to function in the same way. Development initialized in the endogenous sector by itself is theoretically possible, if production capacity of work grows. From the point of view of slow action or little probability of the process it is not possible to recognize it as an initiation of activation of peripheral areas (Sołtys, 2010). However, the endogenous sector can take part in the process of activation initiated by the exogenous sector. As the exogenous activity will increase the demand for services from companies and institutions will also increase, as well as employment and earnings, and thus the purchasing power of the population and its demand for various services and construction will increase, which will lead to the development of endogenous activities.

An important function of most towns are central ones meaning services to the towns and its surroundings. These functions for individual towns are partly endogenous, partly exogenous, or the so-called standard ones, in contrast to other exogenous – specialized (Dziewoński, 1970). At the regional scale these are endogenous activities, so their development faces a demand barrier. This barrier does not apply to public sector services, but their growth is limited by the modest public budget resources, not only for development, but also for subsequent maintenance of the operations.

A majority of central functions are located in centers creating a hierarchical system, compatible with Christaller's theory, but with more and more services located in ways incompatible to that model. This causes the development of motorization, increasing easy accessibility to these activities. Administrative divisions reinforce this hierarchical model. The county (powiat) level is important in the analyzed scale. Capitals of administrative counties concentrate not only offices, but many others services like upper secondary schools, hospitals, bank agencies, and big commercial stores. Coverage of services depends on free choices of clients, but its size is approximated to the administrative county area. Some towns are acting as support for the capitals of counties, some have an intermediate level between the county and borough (gmina) level, few are subregional centers, intermediate between the county and provincial (voivodeship) levels. These levels are not in the administrative division, so in specific towns they are not always clearly recognizable. The development of the central functions of the towns can activate these towns, but their endogenous role at the regional scale should not be the initial impulse for development. Especially development of public educa-

tional services can't be such an impulse because of a demographic decrease that will cause some weaker schools to fall. Development of exogenous (so-called specialized functions), can initiate the activation. Process of activation in the area can be provided as indicated in the Fig. 1 (Sołtys, 2011).

### **3. Factors and spatial conditions of development**

The study area is diverse. Differentiation relates to development factors as well as development level. The key point to determine the possibilities and conditions of development of the study area, and planning regional policy is to answer the following questions:

- 1) What exogenous development factors occur in the area and where? How are they distributed?
- 2) What is the impact area of development factors?
- 3) Is the distribution of the factors needed to develop throughout the periphery? If not, then what parts of the area are deprived of growth factors?
- 4) Does the distribution of factors ensure completeness for these types of development, and which requires more than one factor?
- 5) Do the factors explain the current level of development? What is the correlation between the factors and the level of development?

There was an attempt to answer questions 1, 3 and 5 in previous studies (for three voivodeships), using commonly available data (Local Data Bank, maps). Answers to question 3 require more detailed study and acquisition of new data.

The impact area of development factors (question 2) is difficult to clearly define. The intensity of commuting to work, which plays a big role in activation, decreases with increasing distance. It is possible to accept for the purpose of this study the coverage of 30 km as a distance to work (refer the research for PUP in Kościerzyna – Report, 2008). This corresponds to the size of many counties. Development of the county town can activate the development of the entire county or a substantial part thereof, as shown from these spatial conditions. A model of such development, taking into account the spatial aspects is shown in Figure 1. The county may therefore be a module in the analysis of opportunities for development of peripheral areas and the planning of regional policy. Therefore, a county was adopted as the unit of reference for the researches presented here.



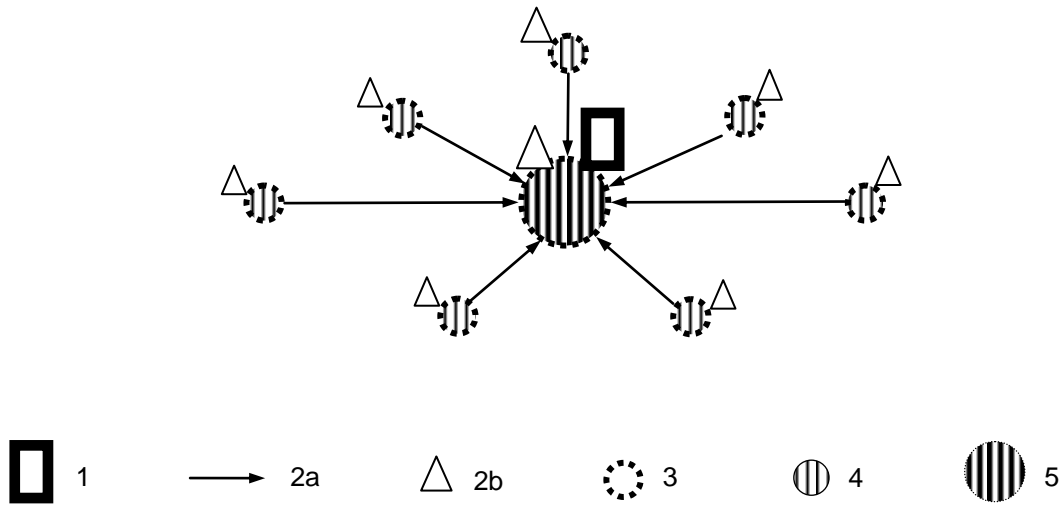

Figure 1. Scenario model of activating the fragment of the peripheral area

Sequence of events: 1 – location of new activities or development of existing exogenous activities and growth of employment, 2 – increase of work trips and in parallel: 2b – increase in revenues of new employees stimulating endogenous demand, 3 – development of endogenous, local and central activities for town and its surroundings boosting employment and revenues of populations, 4 – village, 5 – town.

*Source: Soltys (2011)*

There are not many development factors in the reference area. The most important development factors are natural assets for tourism, but tourism is largely seasonal. The tourist season at the seaside lasts only 2 months, in the lake counties it is 4–5 months. A few facilities and especially the health resorts have a year-long function. The main purpose of these resorts is health care, but their manner of functioning is similar to tourism. The development of tourism is further reinforced by the growth in revenues of related businesses. The population also gains by boosting demand for market services and starting up the new development of them. This model, which takes into account the spatial aspects, is shown in Figure 2. The coverage of development on the basis of income from tourism may include the city nearest individual hierarchical levels, including the nearest county town and to a much lesser extent – the nearest subregional center.

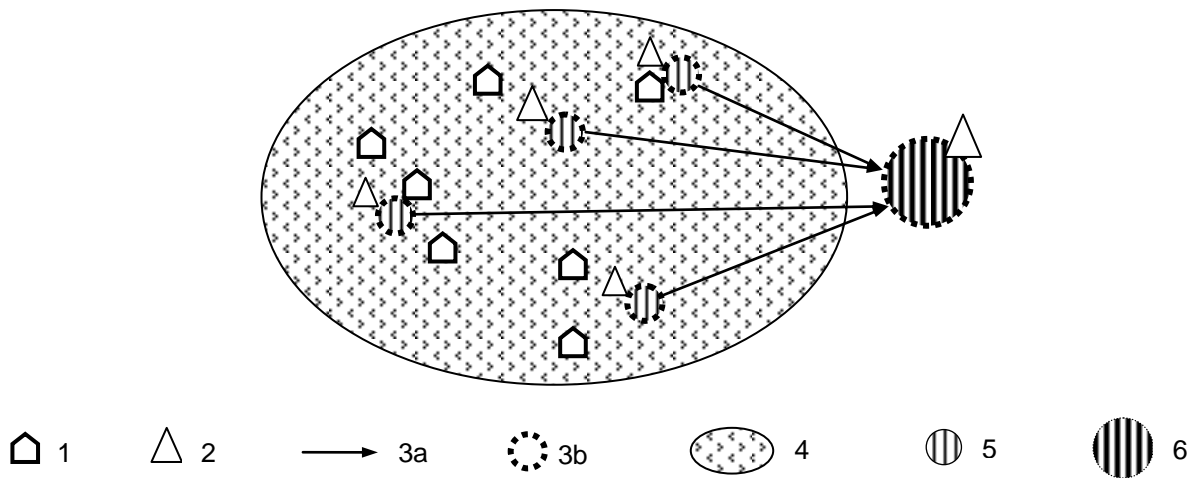

Figure 2. Scenario model of activating a peripheral zone by tourist development  
 Sequence of events: 1 – development of tourism services, 2 – increase in revenues caused by tourism development stimulating endogenous demand, 3a – increase of service trips and in parallel: 3b – development of endogenous, local and central activities boosting employment, 4 – tourist area, 5 – village, 6 – town (especially county capital).

Source: *Own research.*

Sightseeing tourism, especially in some towns, can extend throughout the whole year, but except for a few towns (Malbork, Frombork) the coverage and scale of tourism seems rather small. The role of sightseeing could enhance the development of networking products, such as the “Teutonic Castle Route”. For the development of tourism as a sector of the economy it is necessary to create tourism products that could be sold on the market. This requires adequate human capital (competencies, knowledge, creativity, entrepreneurship) and social capital (trust, cooperation skills).

Therefore, the main way to activate an area to realize the biggest increases not only in revenues, but also employment, would be development of industry and services in the exogenous specialized sector. This can be done through the involvement of new or existing local or external businesses.

Taking into account the above exogenous development, factors that require diagnosis may be:

- Endogenous resources for the development of exogenous;

- Natural and cultural resources for tourism development;
- Human capital, social capital and institutional potential;
- The economic potential of companies operating in the area for industrial development and exogenous services;
- Values for gaining external investments.

The level of human and social capital was not covered by researches which are described here, because it is a comprehensive, complex task.

Natural and cultural resources for tourism were researched by the author. For quantitative analyses they were expressed by points. For presenting natural resources on the map (fig. 4) another source (Narodowy, 1973–1978, p. 6, 7, 124) was used. The level of tourism development as use of tourist values (resources) were researched by the indicators:

- overnight stays (nights spent) in tourist collective accommodation establishments per 1000 capita.
- overnight stays (nights spent) in tourist collective accommodation establishments per 1 km<sup>2</sup>.

It is difficult to extract the economic potential of the companies restricted to the exogenous sector. This sector could be identified as the industry. Therefore, when possible it was isolated using these indicators. The exogenous service is service with indicators significantly higher in some counties in comparison to others. This is only a guess and simplification, but some indicators were also extracted in the case of services.

Counties' town population as an indicator of its size was taken into account as affecting the attractiveness for the external investments (the larger city: the more qualified staff, better business support services, more investment areas).

Transport accessibility should be taken into consideration as a value for the location of the external investments, but it is a distinct and difficult task. Only 4 counties and 11 counties' towns are placed outside national roads. But technical parameters and quality of these roads are diverse. Their improvement is in progress. Motorways and expressways provide the best transport accessibility, though now only 4 counties are connected by these roads to a European motorway network. It is since 2010, so the impact of these connections on development cannot be noticeable in analyzed figures. Planned expressways are important conditions of development, but they will be constructed for more than 15 years. Probably 50% of counties will be outside motorways and expressways in the year 2020 and about 40% of counties will always be outside these roads.

Coverage of the possible activating impact of roads must be taken into account. There is a tendency to locate small and medium plants near local roads with a distance of up to 5 km from the nearest motorway junction. For larger plants this distance is 15 km (Uwarunkowania, 2000). For the expressways, the shorter distance is assumed (10 km). In such conditions, considering the accepted travel distance of 30 km to get to work, it is possible to set up the effective impact of motorways and expressways as shown in figure 3. In this way there can be developed counties located outside, but near existing and planned motorways and expressways.

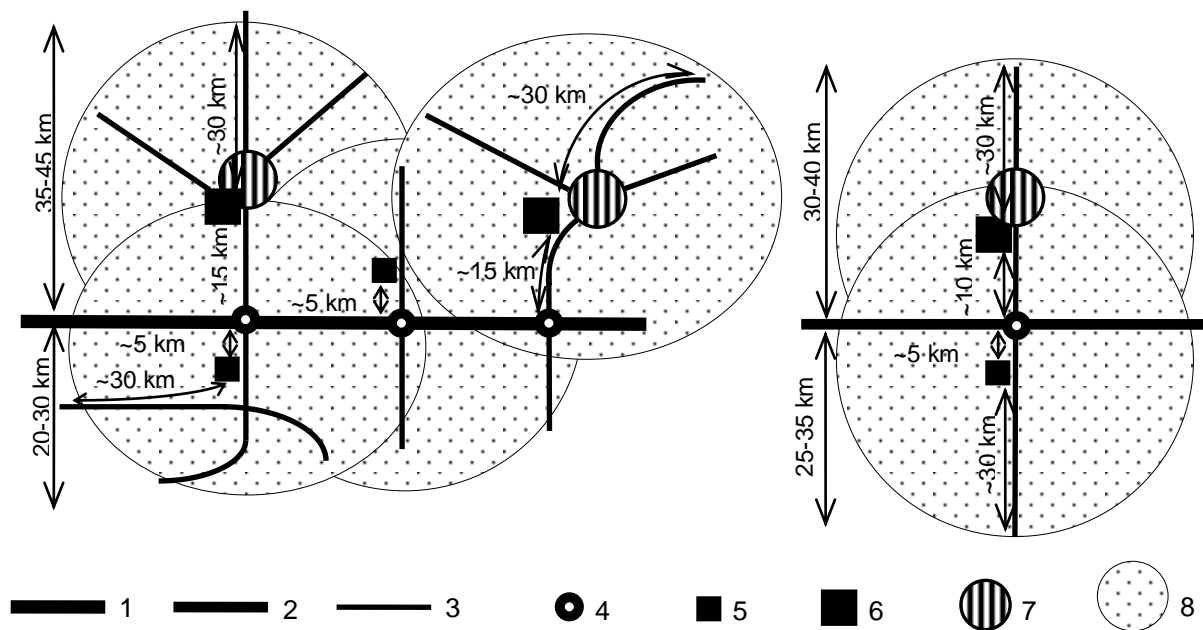

Figure 3. Impact of motorways and expressways

1 – motorway, 2 – expressway, 3 – other roads, 4 – motorway and expressway junction,  
5 – small and medium plants, 6 – larger plants, 7 – towns, 8 – impact area.

Source: *Own research.*

#### 4. Typology of counties

A typology of counties was prepared in order to analyze the diversity of the study area. The first step was to standardize the variables. Then, in order to reduce the number of variables, some of these variables were combined in the following synthetic ones:

- size of enterprises (EN);
- the economic potential of the industrial sector (industry and construction) (IC);
- the economic potential of the service sector (S);

- the level of tourism development (TD).

Variables remaining intact:

- counties' town population (CTP);
- tourism values (TVAL);
- unemployment rate (UR);
- average monthly gross wages and salaries (WS).

The abbreviations of variables used in the tables are in parentheses.

Three urban counties (cities with powiat status) have been combined with the surrounding counties. Otherwise, these counties would be without capitals, and the regional cities without the surrounding counties, so the sizes of these areas would be artificially distorted. The correlations between these eight variables were examined (Pearson's product-moment correlations). The correlation coefficients are shown in table 2.

Table 2

The correlation coefficients

	<b>EN</b>	<b>IC</b>	<b>S</b>	<b>CTP</b>	<b>TVAL</b>	<b>TD</b>	<b>UR</b>	<b>WS</b>
<b>EN</b>	1,000	0,376	0,566	0,462	0,206	0,275	-0,693	0,302
<b>IC</b>	0,376	1,000	0,253	0,366	-0,101	-0,196	-0,523	0,468
<b>S</b>	0,566	0,253	1,000	0,694	0,452	0,586	-0,631	0,491
<b>CTP</b>	0,462	0,366	0,694	1,000	0,267	0,029	-0,525	0,569
<b>TVAL</b>	0,206	-0,101	0,452	0,267	1,000	0,441	-0,242	0,174
<b>TD</b>	0,275	-0,196	0,586	0,029	0,441	1,000	-0,226	0,137
<b>UR</b>	-0,693	-0,523	-0,631	-0,525	-0,242	-0,226	1,000	-0,309
<b>WS</b>	0,302	0,468	0,491	0,569	0,174	0,137	-0,309	1,000

*Source: Own calculations*

The typology was made by data analyst Jarosław Łosiński using the k-means algorithm. The result is shown in table 3 and 4.

Table 3.

## Quantitative characteristic of types

Type	Measure	GDL	EN	IC	S	UR	WS	CTP	TVAL	TD
<b>1</b>	Max.	1,52	1,53	0,43	3,89	-0,50	1,92	3,74	1,66	5,64
	Min.	0,80	1,33	-0,18	0,91	-2,10	0,80	0,57	0,82	-0,36
	SD	0,27	0,08	0,24	1,11	0,63	0,43	1,18	0,33	2,45
	<b>Average</b>	<b>1,25</b>	<b>1,46</b>	<b>0,20</b>	<b>2,32</b>	<b>-1,57</b>	<b>1,25</b>	<b>2,48</b>	<b>1,28</b>	<b>1,41</b>
<b>2</b>	Max.	2,07	1,01	4,39	1,17	0,74	2,23	1,54	0,90	-0,38
	Min.	0,23	-0,27	0,44	-0,86	-1,79	0,94	-0,36	-1,02	-0,42
	SD	0,66	0,43	1,32	0,66	0,88	0,47	0,61	0,66	0,01
	<b>Average</b>	<b>0,81</b>	<b>0,17</b>	<b>1,64</b>	<b>0,25</b>	<b>-0,56</b>	<b>1,50</b>	<b>0,61</b>	<b>-0,46</b>	<b>-0,39</b>
<b>3</b>	Max.	0,85	1,40	1,20	1,07	0,85	0,81	1,08	1,61	1,90
	Min.	-0,29	-0,60	-1,37	-0,47	-2,05	-1,52	-0,83	-0,99	-0,39
	SD	0,31	0,58	0,70	0,43	0,73	0,71	0,47	0,73	0,75
	<b>Average</b>	<b>0,23</b>	<b>0,47</b>	<b>0,02</b>	<b>0,34</b>	<b>-0,33</b>	<b>-0,10</b>	<b>-0,05</b>	<b>0,57</b>	<b>0,19</b>
<b>4</b>	Max.	0,42	1,07	0,34	-0,23	0,72	0,41	-0,37	-0,37	-0,05
	Min.	-0,60	-0,87	-0,59	-1,10	-1,02	-1,95	-0,81	-1,42	-0,46
	SD	0,29	0,57	0,31	0,30	0,50	0,66	0,12	0,35	0,12
	<b>Average</b>	<b>-0,11</b>	<b>0,42</b>	<b>-0,18</b>	<b>-0,68</b>	<b>-0,05</b>	<b>-0,80</b>	<b>-0,63</b>	<b>-0,93</b>	<b>-0,37</b>
<b>5</b>	Max.	-0,40	-0,36	1,01	0,04	1,68	0,58	-0,11	1,32	1,33
	Min.	-1,27	-2,66	-1,56	-1,39	0,04	-1,59	-0,80	-1,56	-0,46
	SD	0,27	0,55	0,62	0,35	0,43	0,64	0,23	1,03	0,50
	<b>Average</b>	<b>-0,85</b>	<b>-1,20</b>	<b>-0,66</b>	<b>-0,65</b>	<b>1,03</b>	<b>-0,39</b>	<b>-0,52</b>	<b>-0,10</b>	<b>-0,17</b>

SD – standard deviation, GDL – general development level

Source: Own calculations

Typologies or classifications of counties prepared in the future should take into consideration expressways that will be built. The most problematic counties will be those outside expressways, which now are in the type 4 and subtype 5c.

Table 4

## Types and subtypes

Number and description of types and subtypes		Counties
Type 1 – the highest level of majority of features, big scale of settlement node and high tourist value as main development factors		Kołobrzegi, Koszaliński with Koszalin city, Słupsk with Słupski, Elbląg with Elbląski
Type 2 – high level of potential of the industrial sector and salaries		Kwidzyński, Tczewski, Szczecinecki, Stargardzki, Gryfiński, Starogardzki
Type 3 – general development level a bit above average; type very diverse (possible division into 3 subtypes)	3a – high tourist value, developed tourism	Lęborski, Kamieński, Gryficki, Mrągowski, Chojnicki
	3b – high tourist value, less developed tourism	Kościerski, Ostródzki, Iławski, Giżycki, Bytowski, Wałecki
	3c – others	Ełcki, Malborski
Type 4 – general development level a bit above average; distinctive features are: low economic potential of the service sector, low counties' town population, lowest salaries, tourism values and tourism development; type little diverse		Działdowski, Myśliborski, Nidzicki, Olecki, Człuchowski, Gołdapski, Sztumski, Lidzbarski, Nowomiejski
Type 5 – the highest level of majority of features (possible division into 3 subtypes)	5a – high tourist value, developed tourism	Sławieński, Nowodworski
	5b – high tourist value, less developed tourism	Piski, Drawski, Braniewski, Węgorzewski, Szczycieński
	5c – others	Bartoszycki, Łobeski, Choszczeński, Białogardzki, Świdwiński, Kętrzyński, Pyrzycki

Source: Own work

## 5. Direction of regional policy

The direction of regional policy supporting tourist products development seems to be obvious, especially in the areas where there are tourist values, and the tourist economy is underdeveloped. Nevertheless, the increase of permanent workplaces as a result of this policy will be small. Creating new jobs can be done by development of the exogenous sector in the towns.

In regional policy key questions are: *which towns should be supported to activate their peripheral areas? Which factors should be supported and where?* There are dilemmas expressed by other, more detailed questions. What is better:

- *Improving the development factors in towns that already have started to activate functions or creation of new centers and new factors in them?*
- *Creating many small activating centers or not many, but at least strong?*
- *Creating new centers or improving access to existing ones?*

Analyses of these dilemmas and proposed answers have been presented (Sołtys, 2011). Included was the statement (which results from spatial conditions), that a daily urban-system, as an area of daily trips to work, can be a module of regional policy. These areas are similar to counties, where the accepted trip distance to work is a maximum of 30 km. This indicates county towns as the base of activation for the peripheral area. In some cases it can be reasonable to specify other centers of activation too, determined by aspects like: distance, the size of the city and transport accessibility (Sołtys, 2010). The best conditions for development are in big cities, but in the study area there are only 3 cities with a population nearly or more than 100 thousand. The direction of regional policy based on towns can be the following:

- 1) Improve the competitiveness of the local exogenous sector (especially small and medium enterprises; a positive outcome can mean small enterprises grow into medium sized ones).
- 2) Improve attractiveness for external investments.

Both directions are possible for one town, but a lack of resources will probably mean that the authorities will have to confront the problem of choosing the actions. Direction 2) can be more effective in towns well connected, but waiting for expressways shown in figure 4 to arise, would be too long. Development of local enterprises can give more sustained effects, because external enterprises (especially transnational corporations) that initially invest will then relocate production to another country where conditions are better. There is a problem concerning the aim of the support. Some businesses achieve great success without supporting



in places, which seems accidental. It is impossible to predict what kinds of support (permitted in the European Union) bring effect, what effect and where.

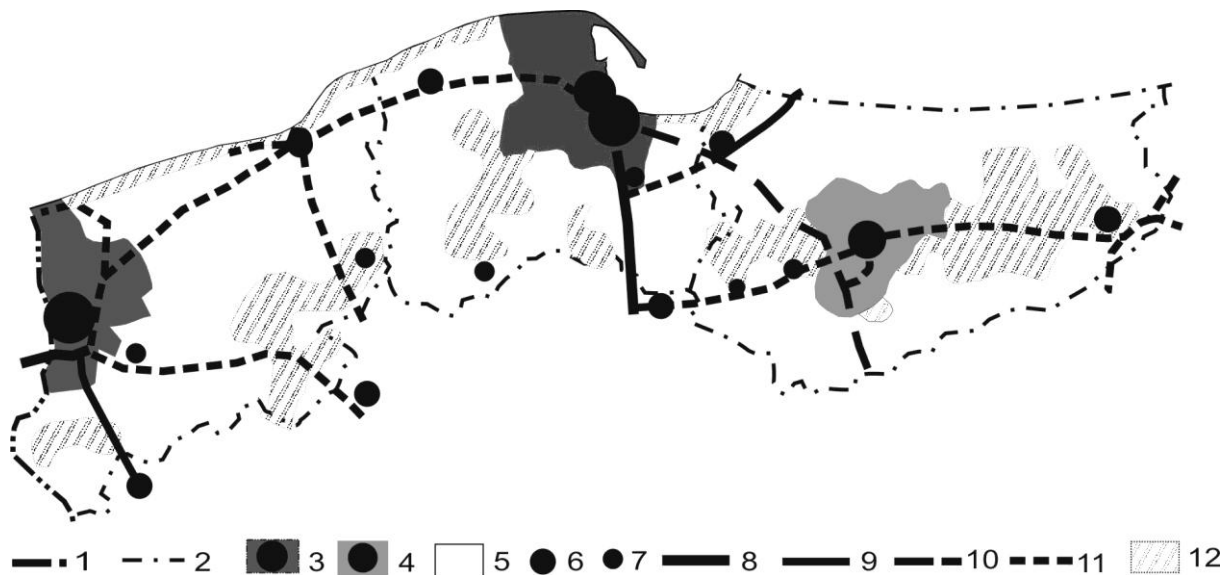

Figure 4. Spatial structure and activation factors of analyzed area

1 – country border, 2 – borders of voivodeship, 3 – metropolitan areas: G- of Gdansk, S- of Szczecin, 4 – other capital of a voivodeship – city of Olsztyn with activated external area, 5 – peripheral areas. Factors of activation: subregional center: 6 – formed, 7 – forming or potential; 8 – existing motorways; expressways: 9 – existing, 10 – in construction, 11- in plans; 12 – natural resources of tourism.

Source: *Koncepcja (2011), Narodowy (1973 – 1978 p. 6, 7, 124) and own work*

In some towns, in parallel with the actions mentioned above, the development of sub-regional services can be supported by development of public services. The support of creation of the new enterprises does not seem to be well grounded economically, despite being the most popular solution. This has previously been explained (Sołtys, 2011).

**Scenario of moderate chances** is quite realistic but with optimism, including directions of policy mentioned above, and can be described in the following way: In some towns enterprises in the exogenous sector give impulse for further development and activation of the surrounding area. Some areas are activated through tourist development. Regional planning manages monitoring, identifies low development areas, defines Strategic Support Areas and indicates among them:

- Subregional Service Centers in which subregional public services will be developed and conditions for location of subregional commercial services will be created,

- Activation Centers for support of the creation and promotion of new investment areas,
- Activation Centers for improvement in the competitiveness of the local exogenous sector.

New investment areas are prepared in steps for investors. It is a reasonably long process. Building of the expressways shown in picture 4 lasts even longer. Only in some areas is it possible to achieve new external investments, in others it is not (they are partially used by local businesses). Only some of the enterprises that gained support achieve greater success. Developing exogenous activities in steps influences the development of towns and their surroundings as shown in figure 1. The activating process is uneven and does not include the whole peripheral areas. Obviously it is impossible to predict in which towns there will be success, and in which there will not.

**Scenario of maximal chances** that all investment areas are used, all Activation Centers are developing and the whole peripheral area is developing is unlikely.

**Scenarios of threats** are more probable as follows:

1. High rate of emigration and regression – resulting in declining development. In this situation active and better-educated people will emigrate. This scenario is likely if barriers to migration have been overcome.
2. Low rate of emigration and stagnation – combined with growing unemployment and other consequences making development of the peripheral area difficult (Sołtys, 2011).

## 6. Conclusions

The exogenous sector can help start the development of peripheral areas. The endogenous sector can be part of a development process that results in the growth of revenues, resident and working populations and businesses that create demand.

An important spatial condition of area activation is 30 km as an accepted distance to work. The daily urban system based on county towns and some other towns can be used as a unit for the regional policy.

Counties are diverse; so various types can be distinguished. Types will be changing as the expressways are being built and transport accessibility is improved. Interventions of the regional policy should also be diverse, taking into consideration the range of impact and the development factors that help to achieve the goal. Spatial analyses in regional planning should facilitate the choice of towns for interventions: Subregional Service Centers and Activation Centers for support in the creation of new investment areas and for improvements in the competitiveness of local exogenous sectors.

There is a great need for research on the efficiency of how different actions impact regional policy in different spatial configurations.

## References

1. *Analiza lokalnego rynku pracy w powiecie kościerskim. Badania wśród osób bezrobotnych. Raport z badań*, Agencja Komunikacji Marketingowej „Interactive”, Kraków 2007.
2. Dawkins C.J., 2003, *Regional Development Theory: Conceptual foundations, classic works and recent developments*, Journal of Planning Literature, 18, 131-172.
3. Domański R., 2005, *Geografia ekonomiczna. Ujęcie dynamiczne*, Wyd. Naukowe PWN Warszawa.
4. Dziewoński K., 1970, *Specialization and urban systems*, Paper in Regional Science vol 24 nr 1, 34–45.
5. *Konceptcja przestrzennego zagospodarowania kraju 2030*, 2011, Ministerstwo Rozwoju Regionalnego, Warszawa.
6. *Krajowa Strategia Rozwoju Regionalnego 2010-2020. Regiony, miasta, obszary wiejskie. Projekt*, 2009, Ministerstwo Rozwoju Regionalnego, Warszawa.
7. *Local Data Bank*, Central Statistical Office, [www.stat.gov.pl](http://www.stat.gov.pl)
8. Miszczuk A., 2010, *Peryferyjność regionów*, [in:] Europejskie wyzwania dla Polski i jej regionów, A. Tucholska (Ed.), Ministerstwo Rozwoju Regionalnego, Warszawa, p. 238-245.
9. *Narodowy Atlas Polski*, 1973 – 1978, Wrocław – Warszawa – Kraków – Gdańsk: Ossolineum, p. 124.
10. *Raport szczegółowy dla powiatu kościerskiego na podstawie badań przeprowadzonych w 2007 r.*, 2008, Human Capital Business, Sopot.
11. Sołtys J., 2010, *Polityka regionalna w aktywizacji obszarów peryferyjnych – wybrane problemy*, [in:] *Oblicza współczesnego kryzysu a polskie regiony*, Z. Strzelecki, P. Legutko-Kobus (Ed.), Ministerstwo Rozwoju Regionalnego, Warszawa, p. 268–279.
12. Sołtys J., 2011, *Towns in the regional policy of activation of peripheral areas – choosing problems – the case of northern Poland*, <http://www-sre.wu.ac.at/ersa/ersaconfs/ersa11/e110830aFinal01688.pdf>

13. *Uwarunkowania kształtowania się strefy rozwojowej*, 2000, Kołodziejcki J., Parteka T., Dutkowski M., Szwankowski S., [in:] *Strefa rozwojowa VI Korytarza TINA*, W. Szydański (Ed.), Urząd Miasta Gdyni, Gdynia.
14. Wojnicka E., 2009, *Metropolie jako bieguny wzrostu*, [in:] *Potencjalne metropolie ze szczególnym uwzględnieniem Polski Wschodniej*, Z. Makiela (Ed.), „Studia KPZK PAN”, vol. CXXV, Warszawa, p. 30-46.