

Sprecher, Arno; Kolisch, Rainer; Drexl, Andreas

Working Paper — Digitized Version

Semi-active, active and non-delay schedules for the resource-constrained project scheduling problem

Manuskripte aus den Instituten für Betriebswirtschaftslehre der Universität Kiel, No. 307

Provided in Cooperation with:

Christian-Albrechts-University of Kiel, Institute of Business Administration

Suggested Citation: Sprecher, Arno; Kolisch, Rainer; Drexl, Andreas (1993) : Semi-active, active and non-delay schedules for the resource-constrained project scheduling problem, Manuskripte aus den Instituten für Betriebswirtschaftslehre der Universität Kiel, No. 307, Universität Kiel, Institut für Betriebswirtschaftslehre, Kiel

This Version is available at:

<https://hdl.handle.net/10419/155398>

Standard-Nutzungsbedingungen:

Die Dokumente auf EconStor dürfen zu eigenen wissenschaftlichen Zwecken und zum Privatgebrauch gespeichert und kopiert werden.

Sie dürfen die Dokumente nicht für öffentliche oder kommerzielle Zwecke vervielfältigen, öffentlich ausstellen, öffentlich zugänglich machen, vertreiben oder anderweitig nutzen.

Sofern die Verfasser die Dokumente unter Open-Content-Lizenzen (insbesondere CC-Lizenzen) zur Verfügung gestellt haben sollten, gelten abweichend von diesen Nutzungsbedingungen die in der dort genannten Lizenz gewährten Nutzungsrechte.

Terms of use:

Documents in EconStor may be saved and copied for your personal and scholarly purposes.

You are not to copy documents for public or commercial purposes, to exhibit the documents publicly, to make them publicly available on the internet, or to distribute or otherwise use the documents in public.

If the documents have been made available under an Open Content Licence (especially Creative Commons Licences), you may exercise further usage rights as specified in the indicated licence.

Nr. 307

**Semi-Active, Active, and Non-Delay Schedules for the
Resource-Constrained Project Scheduling Problem**

Arno Sprecher / Rainer Kolisch / Andreas Drexl

März 1993

Arno Sprecher, Rainer Kolisch, Andreas Drexl, Institut für Betriebswirtschaftslehre,
Christian-Albrechts-Universität zu Kiel, Ohlshausenstr. 40, 2300 Kiel 1, F.R.G.

Abstract: We consider the resource-constrained project scheduling problem (RCPSP). The focus of the paper is on a formal definition of semi-active, active, and non-delay schedules. Traditionally these schedules establish basic concepts within the job shop scheduling literature. There they are usually defined in a rather informal way which does not create any substantial problems. Using these concepts in the more general RCPSP without giving a formal definition may cause serious problems. After providing a formal definition of semi-active, active, and non-delay schedules for the RCPSP we outline some of these problems occurring within the disjunctive arc concept.

Keywords: Resource-constrained project scheduling; semi-active, active, and non-delay schedules; branch-and-bound methods.

1. Introduction

Classification of schedules is the basic work to be done in order to attack scheduling problems. For the case of the Job Shop Problem (JSP) thorough studies have been performed (cf. [Conway et al., 1967], [Baker, 1974], [Rinnoy Kan, 1976], and [French, 1982]). Schedules for the JSP are classified as feasible, semi-active, active, and non-delay schedules. Procedures minimizing a regular measure of performance are usually enumerating semi-active or active schedules (cf. [Rinnoy Kan, 1976]). The latter are known to be the smallest dominant set of schedules (cf. [French, 1982], [Rinnoy Kan, 1976]).

For the resource-constrained project scheduling problem (RCPSP) as a generalization of the JSP the majority of researchers did not make use of any schedule classification (cf. e.g. [Davis/Heidorn, 1971], [Stinson et al., 1978], [Talbot/Patterson, 1978], [Talbot, 1982], and [Patterson et al., 1989]). Some researchers just defined the type of schedule needed. Thereby different definitions have been proposed for the same type of schedules and identical definitions have been used for different kinds of schedules. E.g. Elmaghraby (cf. [Elmaghraby 1977, p. 205]) defines an *eligible schedule* as a schedule where no activity can be started earlier without changing the start times of any other activity and still maintain

feasibility. In Schrage (cf. [Schrage, 1970]) the same type of schedule is called to be an *active schedule*.

Wiest defines a *left-justified schedule* as a "feasible schedule in which ... no job can be started at an earlier date by local left shifting of that job alone" (cf. [Wiest, 1964]) whereas Gonguet calls a schedule left-justified if "each job is scheduled as early as possible" (cf. [Gonguet, 1969]).

Finally other researcher have just taken over the schedule classification of the JSP without modifications (cf. [Radermacher, 1985/86], [Demeulemeester/Herroelen, 1992a], [Herroelen/Demeulemeester, 1992]). This is somewhat reasoned by the way schedule classification is presented in the textbooks for the JSP most oftenly cited (cf. [Baker, 1974], [French, 1982]). There the definitions are more illustrative than formal and thus bear ambiguity in the case of the more general RCPSP.

In order to present a general and precise schedule classification we proceed as follows: Using the schedule classification for the JSP proposed by Baker (cf. [Baker, 1974]) as the stepping stone, we develop more formal and general definitions, that is, schedules for the RCPSP are discriminated to be feasible, semi-active, active, or non-delay schedules. Naturally this classification holds for the JSP as well. Moreover, the (dominance) relations between the different sets of schedules, as known from the JSP, are preserved. This shall help to classify procedures for the RCPSP based on the schedules they examine.

The remainder of the paper is organized as follows: In Section 2 we give a formal description of the RCPSP. The classification of schedules for the RCPSP is dealt with in Section 3. Section 4 then provides examples in order to illustrate the definitions. Furthermore in Section 5 some problems which arise by the adaptation of the disjunctive arc concept (cf. [Balas, 1969]) to the RCPSP (cf. [Radermacher, 1985/86], [Cristofides et al., 1987], [Bell/Park, 1990]) are demonstrated with examples. Finally conclusions are drawn in Section 6.

2. Problem Description

The classical resource-constrained project scheduling problem can be stated as follows: We consider a single project which consists of J activities, $j=1$ ($j=J$) being the unique dummy source (sink). The activities are partially ordered by precedence relations, where P_j is the set of immediate predecessors of activity j . Furthermore the activities are numerically labeled, i.e. a predecessor of j has a smaller number than j . The precedence relations between the activities can be represented by an acyclic activity-on-node network (AON). The set of (renewable) resources is referred to with R . Each $r \in R$ has a limited period availability of K_{rt} units in period t , $t=1, \dots, T$, where T denotes an upper bound on the projects makespan. The activity j , $1 \leq j \leq J$, has a duration of d_j periods ($d_1=d_J=0$) and uses k_{jr} units of resource r , $r \in R$, each period it is in process. All parameters are supposed to be integer valued. Table 1 provides a summary of the symbols and definitions.

$j=1, \dots, J$	activities of a (single) project
$j=1$ ($j=J$)	unique dummy source (unique dummy sink)
d_j	duration of activity j (in periods)
P_j	set of predecessors of activity j
EF_j (LF_j)	earliest (latest) finish time of activity j
ST_j (FT_j)	start (finish) time of activity j
$r \in R$	renewable resource
k_{jr}	job j uses k_{jr} units of resource r each period it is in process
K_{rt}	availability of resource r in period t
T	upper bound on the projects makespan
$t=1, \dots, T$	period

Table 1: Symbols and Definitions

For modelling purposes we use binary variables x_{jt} , $j=1, \dots, J$, $t=EF_j, \dots, LF_j$,

$$x_{jt} = \begin{cases} 1, & \text{if job } j \text{ is finished at time } t, \text{ i.e. at the end of period } t \\ 0, & \text{otherwise} \end{cases}$$

as proposed in [Pritsker et al., 1969]. The earliest finish times, EF_j , and latest finish times, LF_j , are calculated by traditional forward recursion and backward recursion with $LF_j := T$.

$\sum_{t=EF_j}^{LF_j} x_{jt} = 1$	$j=1, \dots, J$	(1)
$\sum_{t=EF_i}^{LF_i} t x_{it} \leq \sum_{t=EF_j}^{LF_j} (t - d_j) x_{jt}$	$j=1, \dots, J, i \in P_j$	(2)
$\sum_{j=1}^J k_{jr} \sum_{\tau=t}^{t+d_j-1} x_{j\tau} \leq K_{rt}$	$r \in R, t=1, \dots, T$	(3)
$x_{jt} \in \{0,1\}$	$j=1, \dots, J, t=EF_j, \dots, LF_j$	(4)

Table 2: Constraints of the RCPSP

The constraints are given in Table 2. (1) ensures that each activity is assigned exactly one finish time within the interval $[EF_j, LF_j]$. (2) secures that precedence relations are maintained and (3) limits the period usage of resources to their availability. With ST_j (FT_j) we denote the start (finish) *time* of activity j , where activity j is scheduled in the *periods* $ST_j+1, \dots, ST_j+d_j=FT_j$. In the example provided by Figure 1 we have $ST_2=0$ ($FT_2=2$) and activity 2 is scheduled in periods one and two.

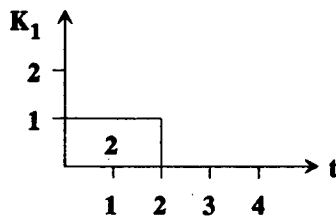

Figure 1: Relationship Between Time and Period

As objective functions we consider only regular measures of performance.

Definition 1 (cf. [Conway et al., 1967], [Rinnooy Kan, 1976])

Let FT_1, \dots, FT_J be the finish times of activities $1, \dots, J$, respectively. A performance measure is a mapping

$$\phi : \mathbf{Z}_{\geq 0}^J \rightarrow \mathbf{R}_{\geq 0}$$

which assigns to each J -tuple (FT_1, \dots, FT_J) of finish times a performance value $\phi(FT_1, \dots, FT_J)$. If ϕ is monotonically increasing with respect to componentwise ordering, that is,

$$\phi(FT_1, \dots, FT_J) > \phi(FT'_1, \dots, FT'_J)$$

implies

$$FT_j \geq FT'_j \quad \forall j, 1 \leq j \leq J,$$

$$FT_j > FT'_j \quad \exists j, 1 \leq j \leq J$$

and in addition minimization is considered, then we call the *performance measure regular*.

The most commonly considered regular performance measure for the RCPSP is the minimization of the makespan:

$$\text{minimize } \sum_{t=EF_j}^{LF_j} t x_{jt} \quad (5)$$

Another one is the minimization of the mean flow time:

$$\text{minimize } \frac{1}{J-2} \sum_{j=2}^{J-1} \sum_{t=EF_j}^{LF_j} t x_{jt} \quad (6)$$

Further regular measures for the RCPSP can be found in e.g. [Slowinski, 1989] and [Patterson et al., 1990].

For ease of notation and the sake of readability we have presented the single-mode version of the RCPSP. In the multi-mode version of the RCPSP (cf. [Talbot,

1982], [Patterson et al., 1990]) basically each activity j , $1 \leq j \leq J$, can be performed in one out of M_j modes. Each mode is characterized by a specific duration d_{jm} and the resource demand k_{jmr} for each $r \in R$. Once each activity j is assigned one of its M_j modes the schedule classification reduces to the single-mode RCPSP.

3. Types of Schedules

To start with we consider the JSP where a number A of jobs have to be processed on M machines. Each job consists of G operations, each of which has to be done on one of the M machines. In the classical JSP the number of operations is equal to the number of machines and each operation of a job has to be processed on a different machine.

It can be easily verified that the JSP corresponds to an RCPSP with $|R|=M$ renewable resources, each of which has an availability of one unit per period (cf. [Schrage, 1970], [Baker, 1974], [Stinson et al., 1978], and [Drexel, 1989]).

As already proposed we proceed as follows: based on the informal definitions given in the JSP context (cf. Baker, [1974]) we extend and formalize them for the RCPSP.

Within the JSP context Baker defines a schedule to be a feasible resolution of resource and logical constraints (cf. [Baker 1974, p. 179]). More precisely we define the following:

Definition 2

A *schedule* S is a J -tuple $S=(ST_1, \dots, ST_J)$, where ST_j denotes the start time of activity j , $1 \leq j \leq J$.

Definition 3

For a given schedule S and a period t , $1 \leq t \leq T$, the set of activities being in progress in period t is $A_t(S)$,

$$A_t(S) := \{ j \mid 1 \leq j \leq J, ST_j+1 \leq t \leq ST_j+d_j \}.$$

Definition 4

A schedule S is called *feasible*, if the precedence relations are maintained, i.e.

$$ST_i + d_i \leq ST_j, \quad j=2, \dots, J, i \in P_j$$

and the resource constraints are met, i.e.

$$\sum_{j \in A_t(S)} k_{jr} \leq K_{rt}, \quad r \in R, t=1, \dots, T.$$

The local or limited left shift for a given schedule S of the JSP is defined as follows (cf. [Baker, 1974, p. 181]): A local or limited left shift is, "moving an operation block to the left on the Gantt chart while preserving the operation sequences". Since the term "operation sequence" is not interpretable within the project scheduling context, we define:

Definition 5 (cf. [Wiest, 1964])

A *left shift* of activity j , $1 \leq j \leq J$, is an operation on a feasible schedule S , which derives a feasible schedule S' , such that $ST'_j < ST_j$ and $ST'_i = ST_i$ for i , $1 \leq i \leq J$, $i \neq j$.

Remark

If a regular measure of performance ϕ is considered and a schedule S' is obtainable from S by a left shift of an activity j , $1 \leq j \leq J$, then S is dominated by S' w.r.t. ϕ .

Definition 6

A left shift of activity j , $1 \leq j \leq J$, is called a *one-period left shift*, if we have $ST_j - ST'_j = 1$.

Definition 7

A *local left shift* of activity j is a left shift of activity j which is obtainable by one or more successively applied one-period left shifts of activity j .

Remark

Within a local left shift each intermediate derived schedule has to be feasible by definition.

Regarding a schedule where no further local left-shifts are possible Baker defines a global left shift, as to start an operation earlier without delaying any other operation (cf. [Baker, 1974, p. 183]). Instead we state:

Definition 8

A *global left shift* of activity j is a left shift of activity j , which is not obtainable by a local left shift.

Remarks

- (a) A global left shift of activity j induces $ST_j - ST'_j > 1$.
- (b) If a feasible schedule S' is derived from the feasible schedule S by a global left shift, then S' is not obtainable from S by a local left shift, since at least one intermediate schedule is not feasible with respect to the resource constraints.

Based on the notion of a local left shift Baker defines the set of semi-active schedules, to be those schedules in which no local left shift is possible (cf. [Baker, 1974, p. 181]). By employing our definition of a local left shift (Definition 7), we define:

Definition 9

A *semi-active schedule* is a feasible schedule, where none of the activities j , $1 \leq j \leq J$, can be locally left shifted.

Remark

A feasible schedule can be transformed into a semi-active schedule by a series of local left shifts. Note that the derived semi-active schedule is in general not unique.

Obviously our definition coincides with the definition given by Baker. The remark "In a semi-active schedule the start time of a particular operation is constrained by the processing of a different job on the same machine or by the processing of the directly preceding operation on a different machine" (cf. [Baker, 1974, p. 183]) has to be generalized in the following way:

Remark

In a semi-active schedule S the start time ST_j of any activity j , $1 \leq j \leq J$, cannot be reduced by one period, because there is at least one resource r , $r \in R$, for which

the left over capacity in period ST_{j-1} is exceeded by the requirements of activity j or at least one predecessor of activity j is not finished up to the end of period ST_{j-1} .

For the JSP the set of active schedules is defined as "the set of all schedules in which no global left shift can be made" (cf. [Baker, 1974, p. 183]). For the RCPSP we use the following generalization:

Definition 10

An *active schedule* is a feasible schedule, where none of the activities j , $1 \leq j \leq J$, can be locally or globally left shifted.

Finally, in the JSP context (cf. [Baker, 1974, p. 185]), a non-delay schedule is a schedule where "no machine is kept idle at a time when it could begin processing some operation". Employing the following remark we can give the more general definition of a non-delay schedule.

Remark

Each RCPSP can be uniquely transformed into a unit-time-duration RCPSP (UTDRCPSP) where each activity j , $1 < j < J$, is split into d_j activities, each of which with duration one (cf. [Davis/Heidorn, 1971], [Demeulemeester/Herroelen, 1992b]). Thus a feasible schedule S of the RCPSP uniquely corresponds to a feasible schedule UTDS of the UTDRCPSP.

Definition 11

A feasible schedule S for the RCPSP is called a *non-delay schedule*, if the corresponding schedule UTDS is active.

By definition we can state the following theorem:

Theorem

Let S denote the set of schedules, FS the set of feasible schedules, SAS the set of semi-active schedules, AS the set of active schedules, and NDS the set of non-delay schedules, then the following holds:

$$NDS \subseteq AS \subseteq SAS \subseteq FS \subseteq S.$$

4. Examples and Illustrations

In order to illustrate the given definitions we consider the example provided in Figure 2 with $|R|=1$.

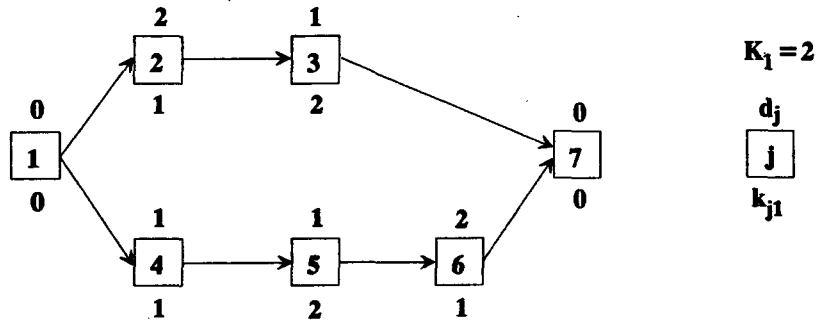

Figure 2: An Example for the RCPSP

A feasible schedule of the above problem is depicted by a Gantt-chart in Figure 3.

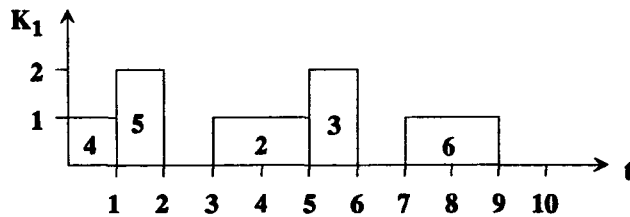

Figure 3: Feasible Schedule for the Example Problem

By performing a local left shift (constituting of a one-period left shift) of activities 2 and 3, respectively, and a local left shift (constituting of two one-period left shifts) of activity 6, the semi-active schedule displayed in Figure 4 is derived. Note that after the first one-period shift of activity 6 the intermediate schedule $S=(0,2,4,0,1,6,8)$ is feasible.

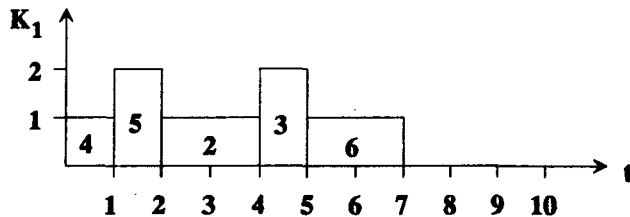

Figure 4: Semi-Active Schedule for the Example Problem

Regarding the semi-active schedule, clearly none of the activities can be locally left shifted anymore. Nevertheless activity 6 can be globally left shifted by performing a three-period left shift. Doing so one achieves the active schedule displayed in Figure 5.

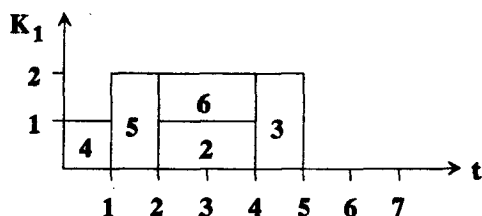

Figure 5: Active (and Unique Optimal) Schedule for the Example Problem

Again, note that the two intermediate schedules $S'=(0,2,4,0,1,4,6)$ and $S''=(0,2,4,0,1,3,5)$ are not feasible and thus we have not performed a local left shift. Since none of the activities can be locally or globally left shifted, the schedule is active. Furthermore the schedule is the unique optimal schedule of the example problem. Optimality can easily be verified by applying the resource-based lower bound as presented in [Stinson et al., 1978], the uniqueness can be shown by performing an explicit enumeration with one of the schemes presented in [Stinson et al., 1978], [Demeulemeester/Herroelen, 1992a].

In order to see, whether the optimal solution is a non-delay schedule or not, we transform the example problem into the corresponding UTDRCPSP, where each activity j , $1 \leq j \leq J$, of the RCPSPP is transformed into the activities j_1, \dots, j_d_j (cf. Figure 6).

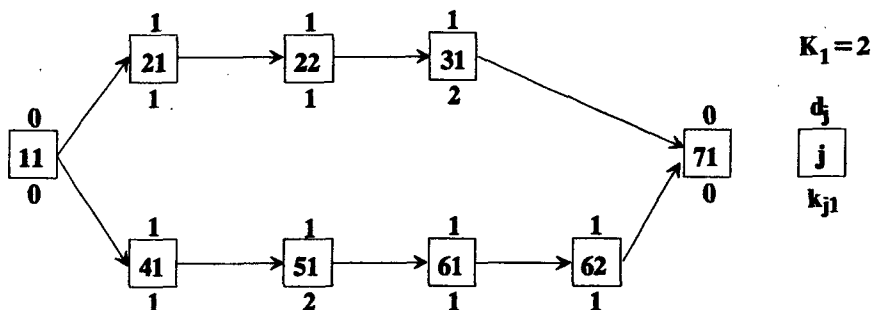

Figure 6: Corresponding UTDRCPSP

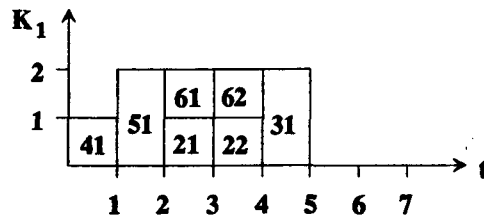

Figure 7: Corresponding Solution for the UTDRCPSP

The corresponding solution is displayed in Figure 7. For this schedule activity 21 can be globally left shifted ($ST_{21}=2 \rightarrow ST'_{21}=0$), therefore the schedule for the RCPSP does not belong to the set of non-delay schedules.

Since the optimal schedule is unique, we can state the following:

When considering a regular measure of performance, the set of non-delay schedules might not contain an optimal schedule.

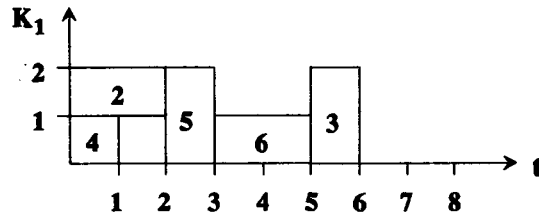

Figure 8: Non-Delay Schedule for the Example Problem

The schedule presented in Figure 8 is the schedule we obtain by assigning activity 2 the start time of 0, which alters the start times of the activities 3, 5 and 6. Again by applying Definition 11, it can be shown that this is a non-delay schedule. Note, since the optimal solution is unique and not a non-delay schedule, we have an empty intersection between the set of optimal solutions and the set of non-delay schedules.

5. Implications for Disjunctive Arc Based Algorithms

As an illustration of the problems encountered by applying the former schedule classification of the JSP (to the RCPSP) the following examples are given:

A well known extension of the disjunctive arc concept (cf. [Balas, 1969]) within the JSP context is the approach via partially ordered sets (posets) (cf. [Radermacher, 1985/86], [Bartusch et al., 1988]) which will now be briefly introduced: An RCPSP is described by the tuple (A, O_0, x, N, κ) with the following meaning:

$A = \{\alpha_1, \dots, \alpha_n\}$: set of activities
O_0	: precedence relations
$x = (x_1, \dots, x_n) \in \mathbb{R}_>^n$: duration vector
$N = \{N_1, \dots, N_k\}$: is a set of \subseteq -incomparable (i.e. $\forall N_i, N_j \in N, i \neq j$, it is $N_i \not\subseteq N_j$) and O_0 -independent (i.e. $\forall N_i \in N$ and $\alpha, \beta \in N_i$ is $(\alpha, \beta) \notin O_0$) subsets of A , which represent those minimal sets of technologically independent activities that are not allowed w.r.t. to resource constraints to be scheduled as a whole at any time.
κ	: regular measure of performance

Using Definition 12 the earliest start schedule $ES_{(A,O)}$ of a feasible poset O can be derived.

Definition 12 (cf. [Radermacher, 1985/86])

Let (A, O_0, x, N, κ) be a scheduling problem. Call a poset (A, O) feasible if $O_0 \subseteq O$ and no $N_i \in N$ is O -independent, i.e. for each $N_i \in N$ there are $\alpha, \beta \in N_i, \alpha \neq \beta$, such that $(\alpha, \beta) \in O$.

Due to the minimality of the sets of N and the feasibility of the extensions of the partial order we now have a scheduling problem $(A, O, x, \{\}, \kappa)$ where the earliest start schedule $ES_{(A,O)}$ calculated by traditional forward recursion is feasible (with respect to resource availabilities). Nevertheless, after the introduction of the

disjunctive arcs the obtained network has to be checked for cycles of positive length in order to meet acyclicity of posets (cf. the JSP-example). For the latter, the resulting earliest start schedule cannot be calculated.

Radermacher (cf. [Radermacher, 1985/1986, p. 233]) states that each earliest start schedule of $ES_{(A,O)}$ with (A,O) feasible belongs to the set of semi-active schedules and that the earliest start schedules of \subseteq -minimal posets (\subseteq -minimal w.r.t. the set of all feasible posets) belong to the set of active schedules. Based on two counterexamples we will show that this generally does not hold for the RCPSP as well as for the JSP.

Consider the RCPSP-example provided in Figure 9 with $A=\{1,2,3,4,5\}$, $x=(0,1,2,3,0)$, O_0 as given by the AON and $N=\{N_1=\{2,3,4\}\}$. Note that the zero duration of dummy source and sink is for convenience of presentation only and is w.l.o.g. not critical w.r.t. the assumptions of the order theoretical approach.

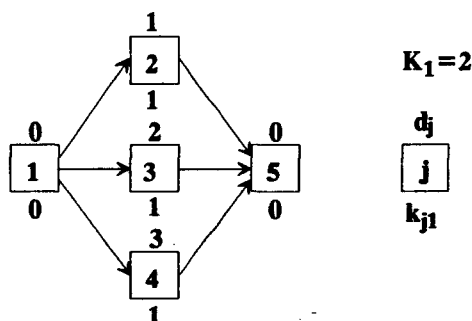

Figure 9: RCPSP-Counterexample

There are 6 \subseteq -minimal feasible posets, $O_1=O_0 \cup \{(2,3)\}$, $O_2=O_0 \cup \{(3,2)\}$, $O_3=O_0 \cup \{(2,4)\}$, $O_4=O_0 \cup \{(4,2)\}$, $O_5=O_0 \cup \{(3,4)\}$, and $O_6=O_0 \cup \{(4,3)\}$. Just the earliest start schedules of the first 3 \subseteq -minimal feasible posets belong to the set of active schedules. Each of the earliest start schedules for the 3 remaining \subseteq -minimal feasible posets will yield a feasible schedule only. Figure 10 shows the feasible schedule resulting for the earliest start schedule of (A,O_6) .

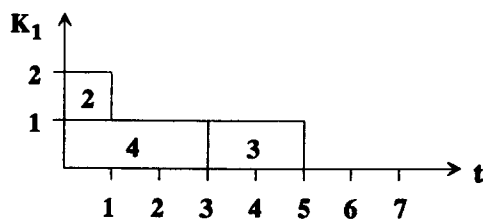

Figure 10: Earliest Start Schedule of (A, O_6) for the RCPSP-Counterexample

Let us further consider the JSP-example provided in figure 11 with $A=\{1,2,3,4,5,6\}$, $x=(0,1,1,1,1,0)$, O_0 as given by the AON and $N=\{\{2,5\}, \{3,4\}\}$.

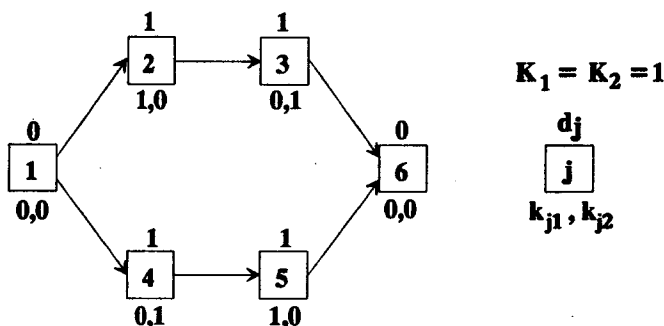

Figure 11: JSP-Counterexample

There are 4 \subseteq -minimal feasible posets $O_1=O_0 \cup \{(2,5), (3,4)\}$, $O_2=O_0 \cup \{(5,2), (3,4)\}$, $O_3=O_0 \cup \{(2,5), (4,3)\}$, and $O_4=O_0 \cup \{(5,2), (4,3)\}$. Just the earliest start schedule of (A, O_3) yields an active schedule, while the earliest start schedule of (A, O_1) (cf. Figure 12) and (A, O_4) will yield a feasible schedule only. Finally the early start schedule associated with (A, O_2) is not feasible because it contains a cycle.

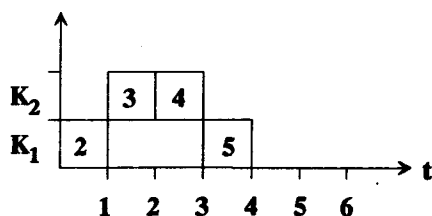

Figure 12: Earliest Start Schedule of (A, O_1) for the JSP-Counterexample

6. Conclusions

The paper provides a formal definition of semi-active, active, and non-delay schedules for the RCPSP. These schedules establish basic concepts within the job shop scheduling literature. There they are usually defined in a rather informal way. Using these concepts in the more general RCPSP without giving a formal definition may cause serious problems. Therefore we formally define semi-active, active, and non-delay schedules for the RCPSP. In addition, we outline some of these problems occurring within the disjunctive arc concept.

Note that currently in several papers, where branch-and-bound methods for the RCPSP are presented, the reader may not find any useful information regarding on which set of schedules the enumeration is performed. Based on the definitions presented above this information can now be given and should be provided in papers to come.

Acknowledgement: The authors are indebted to Rolf Möhring, Technical University of Berlin, for helpful suggestions and comments.

References

- Balas, E. (1969): "Machine sequencing via disjunctive graphs: An implicit enumeration algorithm", *Operations Research*, Vol. 17, pp. 941-957.
- Baker, K.R. (1974): "Introduction to sequencing and scheduling", Wiley, New York.
- Bartusch, M., R.H. Möhring and F.J. Radermacher (1988): "Scheduling project networks with resource constraints and time windows", *Annals of Operations Research*, Vol. 16, pp. 201-240.
- Bell, C.E. and K. Park (1990): "Solving resource-constrained project scheduling problems by A* search", *Naval Research Logistics*, Vol. 37, pp. 61-84.
- Christofides, N., R. Alvarez-Valdes and J.M. Tamarit (1987): "Project scheduling with resource constraints: A branch and bound approach", *European Journal of Operational Research*, Vol. 29, pp. 262-273.
- Conway, R.W., W.L. Maxwell and L.W. Miller (1967): "Theory of scheduling", Addison-Wesley, Reading, Massachusetts.
- Davis, E.W. and G.E. Heidorn (1971): "An algorithm for optimal project scheduling under multiple resource constraints", *Management Science*, Vol. 17, pp. 803-816.
- Demeulemeester, E. and W.S. Herroelen (1992a): "A branch-and-bound procedure for the multiple resource-constrained project scheduling problem", *Management Science*, Vol. 38, pp. 1803-1818.
- Demeulemeester, E. and W.S. Herroelen (1992b): "An efficient optimal solution procedure for the preemptive resource-constrained project scheduling problem", Working Paper, Department of Applied Economic Sciences, Katholieke Universiteit Leuven, Belgium.
- Drexl, A. (1990): "Fließbandaustaktung, Maschinenbelegung und Kapazitätsplanung in Netzwerken", *Zeitschrift für Betriebswirtschaft*, Jg. 60, pp. 53-70.
- Elmaghraby, S.E. (1977): "Project planning and control by network models", Wiley, New York.
- French, S. (1982): "Sequencing and scheduling: An Introduction to the mathematics of the job-shop", Wiley, New York.

- Gonguet, L. (1969): "Comparison of three heuristic procedures for allocating resources and producing schedule", in: Lombaers, H.J.M. (Ed.): "Project planning by network analysis", North-Holland, Amsterdam, pp. 249-255.
- Herroelen, W.S. and E. Demeulemeester (1992): "Recent advances in branch-and bound procedures for resource-constrained project scheduling problems", Working Paper, Departement of Applied Economic Sciences, Katholieke Universiteit Leuven, Belgium.
- Patterson, J.H., R. Slowinski, F.B. Talbot and J. Weglarz (1989): "An algorithm for a general class of precedence and resource constrained scheduling problems", in: Slowinski, R. and J. Weglarz (Eds.): "Advances in project scheduling", Elsevier, Amsterdam, pp. 3-28.
- Patterson, J.H., R. Slowinski, F.B. Talbot and J. Weglarz (1990): "Computational experience with a backtracking algorithm for solving a general class of precedence and resource-constrained scheduling problems", European Journal of Operational Research, Vol. 49, pp. 68-79.
- Pritsker, A.A.B., L.J. Watters and P.M. Wolfe (1969): "Multiproject scheduling with limited resources: A zero-one programming approach", Management Science, Vol. 16, pp. 93-107.
- Radermacher, F.J. (1985/86): "Scheduling of project networks", Annals of Operations Research, Vol. 4, pp. 227-252.
- Rinnooy Kan, A.H.G. (1976): "Maschine scheduling problems: Classification, complexity and computations, Nijhoff, The Hague, The Netherlands.
- Schrage, L. (1970): "Solving resource-constrained network problems by implicit enumeration - nonpreemptive case", Operations Research, Vol. 18, pp. 263-278.
- Slowinski, R. (1989): "Multiobjective project scheduling under multiple-category resource constraints, in: Slowinski, R. and J. Weglarz (Eds.): "Advances in project scheduling", Elsevier, Amsterdam, pp. 151-167.
- Stinson, J.P., E.W. Davis and B.M. Khumawala (1978): "Multiple resource-constrained scheduling using branch and bound", AIIE Transactions, Vol. 10, pp. 252-259.
- Talbot, B. (1982): "Resource-constrained project scheduling with time-resource tradeoffs: The nonpreemptive case", Management Science, Vol. 28, pp. 1197-1210.

Talbot, B. and J.H. Patterson (1978): "An efficient integer programming algorithm with network cuts for solving resource-constrained scheduling problems", *Management Science*, Vol. 24, pp. 1163-1174.

Wiest, J.D. (1964): "Some properties of schedules for large projects with limited resources", *Operations Research*, Vol. 12, pp. 395-418.