

Alba, Isabelita Z.; Reyes, Celia M.

**Working Paper**

## Assessment of Community-Based Systems Monitoring Household Welfare

PIDS Discussion Paper Series, No. 1994-07

**Provided in Cooperation with:**

Philippine Institute for Development Studies (PIDS), Philippines

*Suggested Citation:* Alba, Isabelita Z.; Reyes, Celia M. (1994) : Assessment of Community-Based Systems Monitoring Household Welfare, PIDS Discussion Paper Series, No. 1994-07, Philippine Institute for Development Studies (PIDS), Makati City

This Version is available at:

<https://hdl.handle.net/10419/187257>

**Standard-Nutzungsbedingungen:**

Die Dokumente auf EconStor dürfen zu eigenen wissenschaftlichen Zwecken und zum Privatgebrauch gespeichert und kopiert werden.

Sie dürfen die Dokumente nicht für öffentliche oder kommerzielle Zwecke vervielfältigen, öffentlich ausstellen, öffentlich zugänglich machen, vertreiben oder anderweitig nutzen.

Sofern die Verfasser die Dokumente unter Open-Content-Lizenzen (insbesondere CC-Lizenzen) zur Verfügung gestellt haben sollten, gelten abweichend von diesen Nutzungsbedingungen die in der dort genannten Lizenz gewährten Nutzungsrechte.

**Terms of use:**

*Documents in EconStor may be saved and copied for your personal and scholarly purposes.*

*You are not to copy documents for public or commercial purposes, to exhibit the documents publicly, to make them publicly available on the internet, or to distribute or otherwise use the documents in public.*

*If the documents have been made available under an Open Content Licence (especially Creative Commons Licences), you may exercise further usage rights as specified in the indicated licence.*

## Assessment of Community-Based Systems Monitoring Household Welfare

*Celia M. Reyes and Isabelita Z. Alba*

DISCUSSION PAPER SERIES NO. 94-07

The *PIDS Discussion Paper Series* constitutes studies that are preliminary and subject to further revisions. They are being circulated in a limited number of copies only for purposes of soliciting comments and suggestions for further refinements. The studies under the *Series* are unedited and unreviewed.

The views and opinions expressed are those of the author(s) and do not necessarily reflect those of the Institute.

Not for quotation without permission from the author(s) and the Institute.

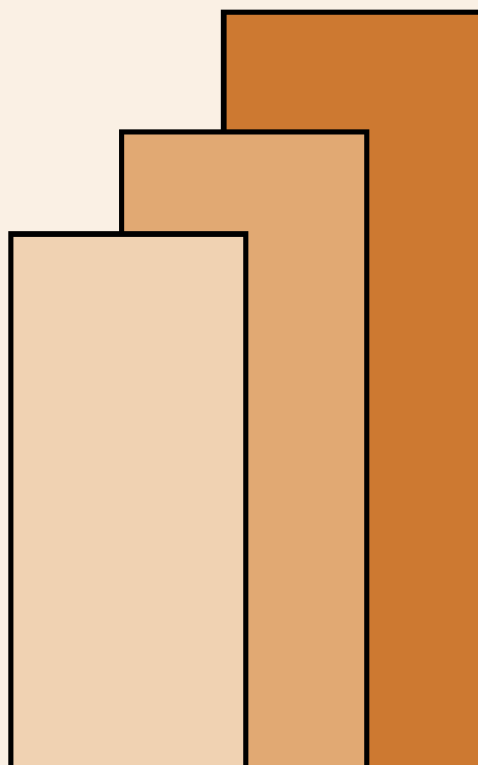

July 1994

For comments, suggestions or further inquiries please contact:

**The Research Information Staff**, Philippine Institute for Development Studies  
3rd Floor, NEDA sa Makati Building, 106 Amorsolo Street, Legaspi Village, Makati City, Philippines  
Tel Nos: 8924059 and 8935705; Fax No: 8939589; E-mail: [publications@pidsnet.pids.gov.ph](mailto:publications@pidsnet.pids.gov.ph)  
Or visit our website at <http://www.pids.gov.ph>

Philippine Institute for Development Studies

**Assessment of Community-Based  
Systems Monitoring Household Welfare**

*Celia M. Reyes and Isabelita Z. Alba*

DISCUSSION PAPER SERIES NO. 94-07

The *PIDS Discussion Paper Series* constitutes studies that are preliminary and subject to further revisions. They are being circulated in a limited number of copies only for purposes of soliciting comments and suggestions for further refinements. The studies under the *Series* are unedited and unreviewed.

The views and opinions expressed are those of the author(s) and do not necessarily reflect those of the Institute.

Not for quotation without permission from the author(s) and the Institute.

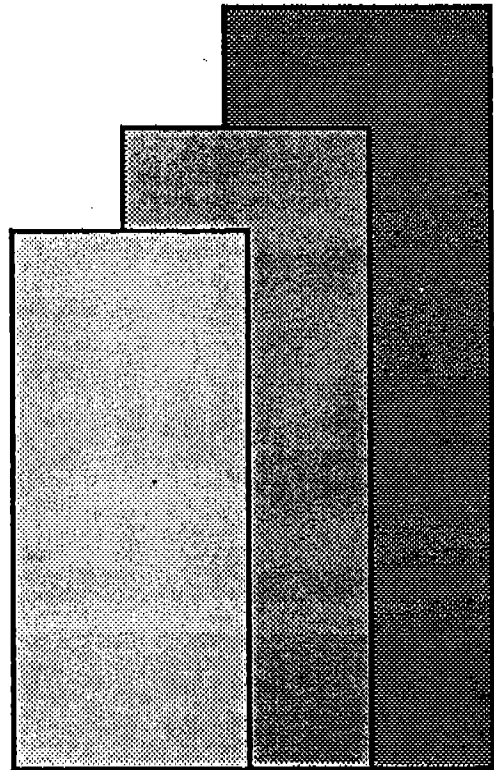

July 1994

For comments, suggestions or further inquiries please contact:

Dr. Cella M. Reyes, Philippine Institute for Development Studies

3rd Floor, NEDA sa Makati Building, 106 Amorsolo Street, Legaspi Village, Makati 1229, Metro Manila, Philippines

Tel No: 8927385; Fax No: (632) 8927385

## TABLE OF CONTENTS

<b>1.</b>	<b>Introduction</b>	<b>1</b>
1.1	Impact of Macroeconomic Adjustment Policies	1
1.2	State of Monitoring of Welfare of the Vulnerable Groups	2
1.3	Objectives of the Paper	3
<b>2.</b>	<b>Inventory and Review of Existing Monitoring Systems</b>	<b>4</b>
2.1	Barangay Integrated Development Approach for Nutrition Improvement of the Rural Poor (BIDANI)	4
2.2	Community-Based Child Monitoring System (CBCMS)	9
2.3	Integrated Rural Accessibility Planning (IRAP) Project	15
2.4	Review of Existing NGO Monitoring Systems	17
2.4.1	Community Information and Planning System	18
2.4.2	The Community Health through Integrated Local Development Project in Region XI	21
2.4.3	Partnership Mechanisms in the Management of Basic Health Care Programs and Services	25
2.4.4	Community-Based Monitoring under the Urban Basic Services Programme	29
<b>3.</b>	<b>Inventory and Review of Proposed Monitoring Systems</b>	<b>32</b>
3.1	Social Welfare and Community Development Indicator System (SWCDIS)	32
3.2	Community-Based Information System (CBIS) and Local Information System (LIS) for Monitoring and Evaluating the Philippine Plan of Action for Children (PPAC)	36
3.3	District-Based Statistical and Information System with Community Sentinels	39
<b>4.</b>	<b>The Proposed MIMAP Monitoring System</b>	<b>42</b>
<b>5.</b>	<b>Conclusion</b>	<b>51</b>
	<b>References</b>	<b>56</b>

## **LIST OF TABLES**

Table	1	Minimum Basic Needs (MBN) Indicators
	2	Geographical Coverage of Various Monitoring Systems
	3	Indicators Generated by Various Monitoring Systems, By Area of Concern
	4	Monitors Utilized By Various Monitoring Systems

## **LIST OF FIGURES**

Figure	1	Flow of Report Submission: BIDANI
	2	Vertical Flow of Information: CBCMS
	3	Community-Based Monitoring System under UBSP
	4	SWCDIS Information Flow
	5	SWCDIS Monitoring Activities, by Agency
	6	MIMAP Monitoring System: Flow of Information

## **ANNEXES**

- Annex A      Tanauan Indicator System, 1990**
- B      Duties and Responsibilities of Persons/Groups Involved in the  
            Installation and Maintenance of the BIDANI Databank**
- C      The Barangay Health Data Board**
- D      SWCDIS List of Indicators**
- E      Agencies/Offices Involved in Social Welfare and Community  
            Development**
- F      Minimum Basic Needs for the Philippine Plan of Action for  
            Children**
- G      Duties and Responsibilities: Local Planning and Development  
            Coordinator**
- H      Duties and Responsibilities: Local Information Officer**
- I      Duties and Responsibilities: Municipal Government Operations Officer**

**ASSESSMENT OF COMMUNITY-BASED SYSTEMS  
MONITORING HOUSEHOLD WELFARE\***  
*by Celia M. Reyes\*\* and Isabelita Z. Alba\*\*\**

**1. INTRODUCTION**

**1.1 Impact of Macroeconomic Adjustment Policies**

The analysis of the micro impacts of macroeconomic adjustment policies is quite new. It developed out of the concern that adjustment policies adopted by governments to correct macroeconomic imbalances have affected various groups in the economy differently. The experience of several countries who have undertaken adjustment policies have indicated that these policies tended to be deflationary and that most of the adjustment costs have been borne by the more vulnerable groups. The predominantly deflationary nature of adjustment policies led to depressed employment and real income resulting to higher poverty incidence. Moreover, some macro policies have direct negative effects on the welfare of these vulnerable groups (Cornia, Jolly and Stewart, 1987).

In response to the search for alternative adjustment paths that would minimize the social costs, the Micro Impacts of Macroeconomic Adjustment Policies (MIMAP) Project was conceived. Under Phase I of the MIMAP Project, Lamberte et al (1991) developed a general framework for analyzing the micro impacts of macroeconomic adjustment policies. Their main finding was there were many studies looking at the impacts of macroeconomic adjustment policies on macro aggregates and also several studies examining the proximate determinants of household or individual welfare. However, there was very little research linking the two sets of studies together.

The MIMAP Phase II Project was able to identify the links between macroeconomic adjustments policies and households/firms. Moreover, a set of indicators were identified that would monitor the welfare status of the households. Unfortunately, empirical testing of these hypothesized relationships and monitoring of these indicators were not undertaken because of the inadequacy of the existing data systems and quantitative models in the Philippines. Hence, MIMAP Phase III was developed.

---

\*Paper presented at the First MIMAP Technical Workshop held at Caylabne Bay Resort, Ternate, Cavite on February 17-18, 1994. Revised 31 May 1994.

\*\*Research Fellow, PIDS and Project Director, MIMAP Project.

\*\*\*Research Associate, MIMAP Project.

The authors are grateful to Mr. Tomas P. Africa, the members of the Policy and Research Advisory Councils of the MIMAP Project, and the other participants of the technical workshop for their helpful comments, and to Ms. Vanessa Ann H. Mina for her invaluable research assistance.

The overall goal of the MIMAP Phase III Project is to provide policy makers with a good information base on the possible impacts of macroeconomic adjustment policies at the firm, household and individual levels, particularly those belonging to the vulnerable groups. This will be achieved by developing and institutionalizing a monitoring system consisting of a set of macro and micro level indicators.

## **1.2 State of Monitoring of Welfare of the Vulnerable Groups**

The review of Lamberte et al (1991) points out the lack of a monitoring, information and feedback system to assess the impact of macroeconomic adjustment policies on the micro level. While there are regular and timely data on macro variables such as inflation rate, exchange rate, and trade balance, there is no systematic and regular collection of information on the "human dimension".

Data on household/individual welfare can be obtained from censuses, surveys and administrative reporting systems of various national agencies. These are insufficient, however, to meet the requirements of a MIMAP monitoring system which calls for regular and frequent monitoring of the welfare conditions of the vulnerable groups. Florentino and Pedro (1992) proposes a community-based monitoring system for MIMAP which will tap the capability of the communities for data generation and utilization.

Presently there is no known established statistical system at the barangay level where information is regularly collected for the use of the local leaders. Government agencies, such as the Department of Agriculture, Department of Agrarian Reform, Department of Health and the Department of Local Government undertake some data collection for their own needs. In some barangays, some data collection is undertaken on an ad hoc basis to satisfy their requirements for reporting and planning.

Gironella et al (1993) cites several reasons why statistical information has not been produced nor effectively utilized at the village level. One is the lack, if not the absence, of training of the villagers on the production or use of these statistical information for planning and decision-making. Second is the statistical information provided is at a higher level of disaggregation for it to be useful at the village level. Third is the statistical information may not have reached the community due to poor communication/transportation services in the area. Fourth is the environment for objective planning and decision-making at the village level has not been given the attention and support it needs.



### **1.3 Objectives of the Paper**

This paper takes off from the work of Florentino and Pedro under MIMAP Phase II. In their paper, Florentino and Pedro reviewed the existing censuses, surveys, and administrative reporting systems of various government agencies focusing on the indicators that can be obtained from them. They also proposed a MIMAP Monitoring System. This paper aims to augment the previous review by focusing on community-based monitoring systems, including those that are not part of the regular statistical system. The different systems are evaluated not just in terms of the data that they generate but more in terms of the viability of the system. The paper also aims to finalize the design of a community-based monitoring system based on the system proposed by Florentino and Pedro by modifying some of the original features and providing details on the other components. In particular, this paper seeks:

- (a) to make an inventory of existing and proposed community-based monitoring systems;
- (b) to evaluate these monitoring systems as a source of regular data on the welfare status of the target population;
- (c) to come up with a list of MIMAP indicators;
- (d) to identify potential monitors at the barangay and municipal levels;
- (e) to identify potential linkages with existing monitoring systems; and
- (f) to specify a scheme to institutionalize the monitoring system.

Chapter 2 is devoted to a review and assessment of existing community-based monitoring systems while Chapter 3 focuses on proposed community-based systems. Chapter 4 presents the proposed MIMAP monitoring system. Chapter 5 presents a summary and conclusion of the paper.

## 2. INVENTORY AND REVIEW OF EXISTING MONITORING SYSTEMS

The following chapter covers an assessment of existing special systems monitoring household welfare, namely: the Barangay Integrated Development Approach for Nutrition Improvement of the Rural Poor; the Community-Based Child Monitoring System; and the Integrated Rural Accessibility Planning Project. This essentially involves: (a) a review of the objectives, coverage, indicators, and the mechanism by which data are collected, processed, and analyzed; and (b) an evaluation of the strengths and limitations of the monitoring system. A summary of the review of the monitoring systems of selected non-governmental agencies (NGOs) is also included in this chapter.

### 2.1 Barangay Integrated Development Approach for Nutrition Improvement of the Rural Poor (BIDANI)

*Objectives.* The BIDANI, initially called the Nutrition Improvement Model, was conceived in early 1978 at the University of the Philippines at Los Banos to address the problem of malnutrition through an integrated development approach that complements traditional nutrition interventions. BIDANI specifically aims to:

- (a) establish practical models of improving nutrition of the rural poor at the local level;
- (b) develop practical training courses for barangay leaders and trainers;
- (c) develop packages of participatory services at the village level;
- (d) institutionalize the models for speedy, sustained and wider implementation at the municipal and barangay levels; and
- (e) sustain the implementation of BIDANI through the assistance of state colleges and universities (SCUs) in the Philippines as a complementary effort to the *Lalakas ang Katawang Sapat sa Sustansiya (LAKASS)* Program of the National Nutrition Council.

*Coverage.* The BIDANI Program focused on model development and testing in its first few years. Six pilot barangays in Laguna and Batangas were initially chosen based on the type of agricultural pursuit. Over the years, BIDANI has expanded as it covered more barangays. Currently, it consists of a network of BIDANI model projects in seven regions spearheaded by key regional SCUs. U.P. at Los Banos serves as the trainer and overall

coordinator of the Program. In the next five years, the BIDANI Network is envisioned to be expanded and institutionalized to cover 683 villages in 75 municipalities in seven regions.

**Indicators.** Although BIDANI focuses on health and nutrition, it also touches on other areas of concern such as food production and utilization, income generation and employment, infrastructure development, education and training, institutional support development, sports development, peace and order, and spiritual development. The basic tool used in identifying and selecting relevant indicators is the Hypothetical-Input-Process-Output-Outcome (HIPPOPOC) table. This table particularly enables one to isolate output from outcome. An examination of the indicator system devised for the municipality of Tanauan, Batangas used for the evaluation of its Integrated Development Plan in 1990 shows that its indicators on health, nutrition and sanitation closely correspond to the Minimum Basic Needs (MBN) indicators. The other BIDANI indicators, however, basically monitor the effectivity of development programs and projects. (See Annex A for the list of indicators).

**Monitoring System.** The BIDANI approach involves the formulation of the Barangay Integrated Development Plan (BDIP) designed by the community members themselves. This BDIP embodies the situational analysis or the socio-economic profile of the community, the prioritized needs and problems, and the operational plan for the projects and activities of the barangay. The situational analysis is based on a survey conducted by the Barangay Nutrition Scholar-Development Worker (BNS-DW). Thus, relevant data are collected on an annual basis as inputs to the development planning process at the barangay level. Moreover, these data are used in monitoring and evaluating the development program. Evaluation, both internal and external, normally consists of process and impact assessment.

The BNS-DW plays a very important role as the monitor at the barangay level. Among his responsibilities are to:

- (a) gather program related data in the barangay;
- (b) plan, implement and evaluate the BIDP together with the Planning and Implementing Committee (PPIC);
- (c) act as liaison officer between barangay people and other entities;
- (d) act as trainer at the local level;
- (e) serve as member of the technical staff of the Barangay Captain, Barangay Development Council, and the PPIC; and
- (f) act as a Barangay Action Officer.

In every barangay, the residents and the barangay officials select and recommend a potential BNS-DW based on the following criteria:

- (a) at least a high school graduate;
- (b) preferably 25 years old or older;
- (c) possesses leadership qualities or is a recognized/respectable person;
- (d) shows deep concern for the welfare of the barangay;
- (e) has more or less established credibility in the barangay;
- (f) available and willing to perform the task assigned to him/her; and
- (g) preferably a current indigenous local agency worker e.g., BNS, Barangay Service Point Officer (BSPO), Barangay Health Worker (BHW).

A major step in the evaluation stage of the Development Plan is the installation and maintenance of a data bank at the municipal level. Data collected by the BNS-DW are submitted to the Supervisory Team consisting of field technicians for validation. The Supervisory Teams provide copies of the reports to the Management Staff composed of the heads of various line agencies for further appraisal of data quality. Reports are then forwarded to the City/Municipal Planning and Development Coordinator (C/MPDC) or the City/Municipal Nutrition Action Officer (C/MNAO). The C/MPDC or the C/MNAO cooperates with non-governmental organizations (NGOs) towards sharing information. Reports from the Management Staff/NGOs are coded and organized. These reports serve as inputs in the evaluation and reprogramming of the City/Municipal Integrated Development Plan (C/MIDP). (See Figure 1 for the flow of report submission). Annex B summarizes the duties and responsibilities of persons/groups involved in the installation and maintenance of the data bank.

***Evaluation.*** The BIDANI approach provides evidence that a community-based monitoring system is viable. The system demonstrates that with adequate training, the barangay councils can generate enough information necessary to formulate a basic development plan. Among its strengths are: (a) implementation and sustainability of the Program on a wider scale is facilitated through institutionalization at the municipal/city level; (b) puts to practice the local government code of decentralization; (c) provides academic institutions an important role in the technical aspect of the Program such as training and research; and (d) provides linkages among the local government, NGOs, academic institutions, and community organizations.

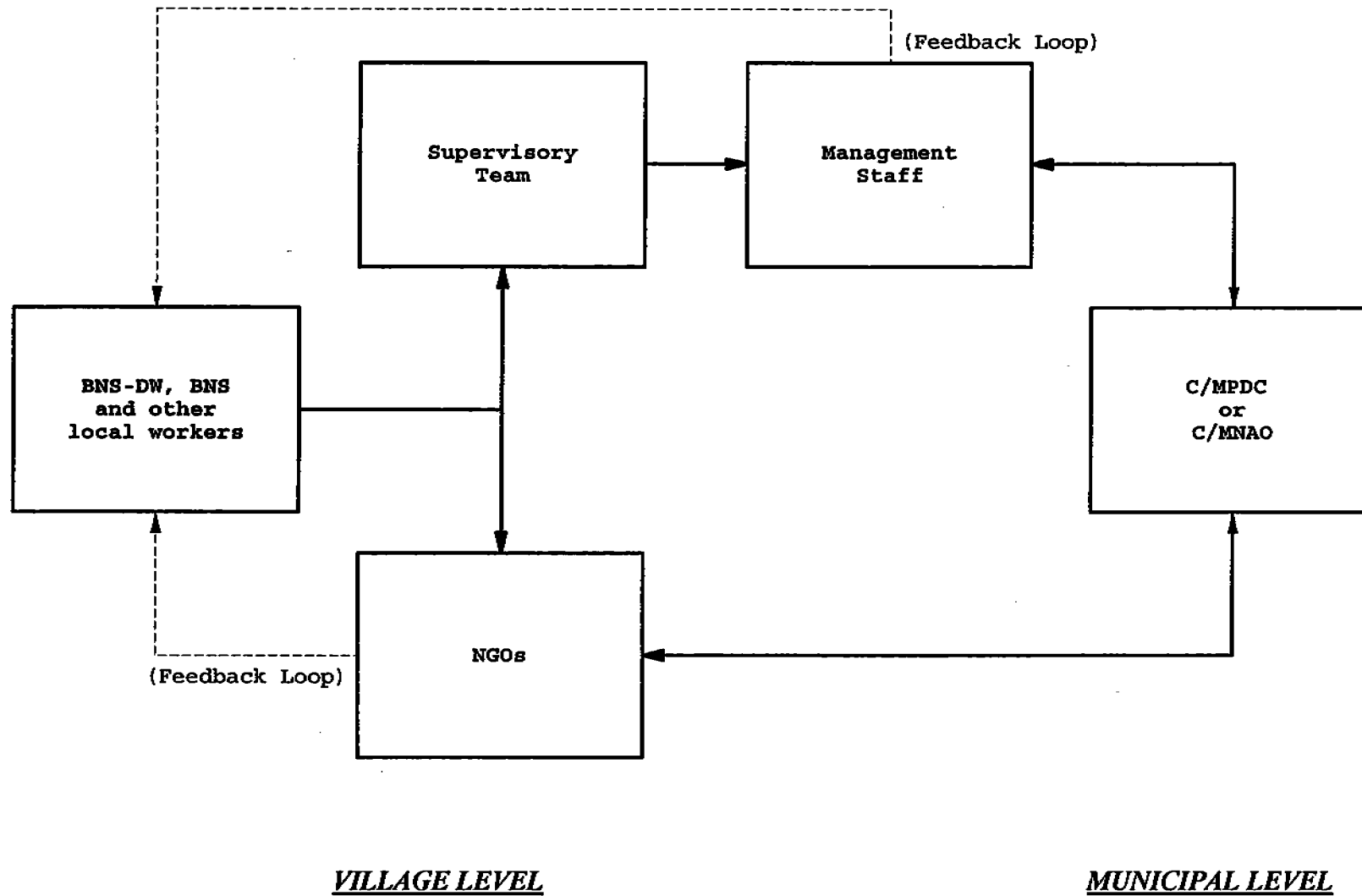

**Figure 1**  
**FLOW OF REPORT SUBMISSION: BIDANI**

Despite its success, there are still some aspects that could be improved. Currently, there are only approximately 14,500 BNS out of 45,000 barangays due to the slow pace of implementation of the BNS Project towards having at least one BNS per barangay. In addition, too many BNS are supervised by only one C/MPDC. Furthermore, a core set of indicators that would facilitate monitoring across time and across barangays has not been identified.

Moreover, based on the information gathered by the MIMAP Project Management Office during a visit to a BIDANI municipality in Laguna, data files are not properly stored in the barangay. Thus, no time series of the data collected exists. The BNS practically "owns" the data files and disposes of them whenever and however they want to. It appears, too, that the information submitted to the municipal level are usually lost and on the other hand, processed information at the municipal level are not fed back to the barangay.

## 2.2 Community-Based Child Monitoring System (CBCMS)

**Background.** The National Statistical Coordination Board (NSCB) initiated in 1988 the Development of a Data System for Monitoring the Situation of Children and Women, which is otherwise known as the Child Monitoring Project (CMP). The main objective of CMP is to operationalize the information system on children and women by establishing a Child Monitoring System at the national and provincial/city levels. The CMP is currently being implemented in seven provinces of the Area-Based Child Survival and Development Programme (ABCSDP), namely: Ifugao, Negros Occidental, Basilan, Maguindanao, Lanao del Sur, Sulu, and Tawi-tawi; and four cities of the Urban Basic Services Programme (UBSP), namely: Cebu, Bacolod, Cadiz, and Cotabato. From the CMP experience, however, emerged the problem of the lack of information at the barangay level which could be used for focused targeting and for assessing the impact of program intervention on the direct beneficiaries. Thus, in response to the need for local level data, the CBCMS was conceived as a sub-component of the CMP.

**Objectives.** The CBCMS seeks to attain the following general objectives:

- (a) to develop and institutionalize the capability of the community to generate and use periodic data about the situation of children and women;
- (b) to provide early warning information on impending problems affecting children and women, in particular, and the community, in general, and to identify the appropriate quick response mechanisms in addressing these problems; and
- (c) to enhance linkages and support mechanisms from existing delivery systems at the barangay level in the short-term, and the municipal and provincial levels in the long-term.

More specifically, the CBCMS aims to achieve the following:

- (a) to provide the community with up-to-date information on the changing conditions of women and children at regular intervals;
- (b) to help improve services in the community related to the situation of women and children;
- (c) to train CBCMS monitors on information gathering, analysis, and sharing; and

- (d) to assist the community in deciding what to monitor regarding the situation of women and children.

**Coverage.** The CBCMS was pilot tested for a period of one year starting June 1991 in four of the seven provinces of the ABCSPD. These provinces were: Ifugao, Negros Occidental, Maguindanao, and Tawi-tawi. For each province, two municipalities were chosen as field test sites, and for each municipality, two barangays were selected. A total of sixteen (16) barangays were selected. All households within the barangays were covered in the field test.

The following criteria were used for selecting the field test sites:

- (a) High malnutrition rate
- (b) Low income
- (c) Additional criteria agreed upon in provincial consultations such as accessibility, peace and order situation, geographic representation, etc.

NGOs and local research institutes (LRIs) were the implementors of the CBCMS field tests. The CBCMS is currently being implemented, installed, and institutionalized in the Project Areas.

**Indicators.** Statistics generation was rationalized and prioritized within a conceptual framework developed for effectively monitoring child survival and development. This framework consists of the following components:

- (a) the status of women and children -- prevailing situation of women and children, the overall improvement of which is the object of programme interventions;
- (b) the care of women and children -- actual interventions effected by the delivery system at the barangay level in order to improve the status of women and children;
- (c) the socio-economic and environmental context -- social, economic, and environmental condition in which children and women thrive;
- (d) the socio-political and community participation -- mobilization activities taking place at the grassroots level; and



- (e) programme management and partnership -- joint endeavors of the Philippine government and UNICEF towards improving and monitoring changes in the overall situation of women and children.

The specific indicators to be measured within these five components are identified by the community members themselves based on their needs. During the CBCMS field test, however, the following core indicators were identified as needed in a typical Philippine barangay:

Core Indicators to be Monitored on an Annual Basis:

- (a) Percentage of infants to total number of children
- (b) Percentage of women to total population
- (c) Annual family income
- (d) Percentage of households with access to safe water supply
- (e) Percentage of households with access to sanitary toilet facilities

Core Indicators to be Monitored on a Quarterly Basis:

- (a) Total number of births
- (b) Total number of infant deaths
- (c) Percentage of underweight preschoolers to total children 0-6 years old
- (d) Percentage of infants fully-immunized
- (e) Total number of maternal deaths
- (f) Percentage of pregnant women immunized with Tetanus Toxoid 2 (TT2)

These core indicators need to be supplemented with area-specific indicators which are of particular importance to the community. The variables needed are then added to the monitoring forms.

The core indicators are significantly fewer than the MBN indicators, and are, obviously concerned only with the situation of women and children in the areas of health, nutrition and sanitation.

**Monitoring System.** The CBCMS is basically an approach whereby the community members themselves monitor the situation of their own women and children. Data gathering and processing is undertaken at the barangay level through a network of volunteer monitors. It has a built-in quick response mechanism in which the villagers are encouraged to act upon existing problems and needs identified during the monitoring period.

The following strategies are employed to achieve the objectives of the CBCMS:

- (a) the conduct of a sustained public information campaign in the community about the goals of the CBCMS;
- (b) the utilization of the Community Organization (CO) Approach for village social mobilizations;
- (c) the establishment of a social network of monitors from the household clusters to the sitio and barangay levels;
- (d) the development of the skills of the community members in information gathering, analysis, and sharing; and
- (e) working hand-in-hand with the local government in the implementation of the CBCMS.

Volunteer monitors (VMs) are solicited during the village general assembly when the CBCMS is explained to the residents. Criteria used for selecting the VMs are as follows:

- (a) Knows how to read and write
- (b) Willing to work on a voluntary basis
- (c) An actual resident of the cluster of households where he/she will be assigned to monitor
- (d) Acceptable to other community members to act as a monitor.

The VMs choose from among themselves the *sitio*, *purok*, and barangay coordinators. These monitors are not only responsible for receiving accomplished monitoring forms from households and coordinating CBCMS activities but also for collecting data which are already available at the *sitio/purok* and barangay levels such as malnutrition data from the local health center.

Data collection is simultaneously done by the VMs on a designated day within the quarter. Once a year, the baseline information are also updated. A day after the monitoring period, the VM processes the information that he/she gathered and submits his report to the barangay monitor on the third day. The barangay monitor is responsible for tallying the results for the whole barangay. Preliminary analysis of the data is performed by the VMs at their respective levels which are presented to the community in a general assembly. The villagers validate the monitoring results, reflect on the situation of their women and children, and make necessary recommendations.

CBCMS data are valuable in formulating the Barangay Development Plan. The results of each monitoring period is submitted officially by the Barangay Monitor to the Barangay Development Council (BDC) through the

Barangay Captain.

The flow of information does not end at the barangay level. CBCMS is expected to be submitted by the Barangay Captain to the Municipal Planning and Development Coordinator (MPDC). The MPDC, in turn, submits the municipal CBCMS results to the Provincial Planning and Development Coordinator (PPDC). Through this vertical flow of information, CBCMS shall provide each administrative level with the necessary data that could form the basis for local development planning, particularly in matters affecting children and women. (See Figure 2 for the CBCMS vertical flow of information).

***Evaluation.*** This monitoring system has the following advantages: (a) caters to the entire barangay population, thus covering both programme beneficiaries and non-beneficiaries; (b) taps existing village associations and indigenous common structures; (c) aims to establish a link between the NGO-initiated information systems and those of government agencies because data already available from these sources are also collected and validated; and (d) puts to practice the local government code of decentralization.

On the other hand, the system has the following limitations: (a) volunteer system may be difficult to sustain because of the non-provision of cash incentives; (b) the process of setting up CBCMS and eventual institutionalization might be difficult or might take longer in communities with less organized POs, and even more so in barangays without POs; (c) political affiliations of volunteer monitors may affect success of the system; and (d) focuses only on the situation of women and children.

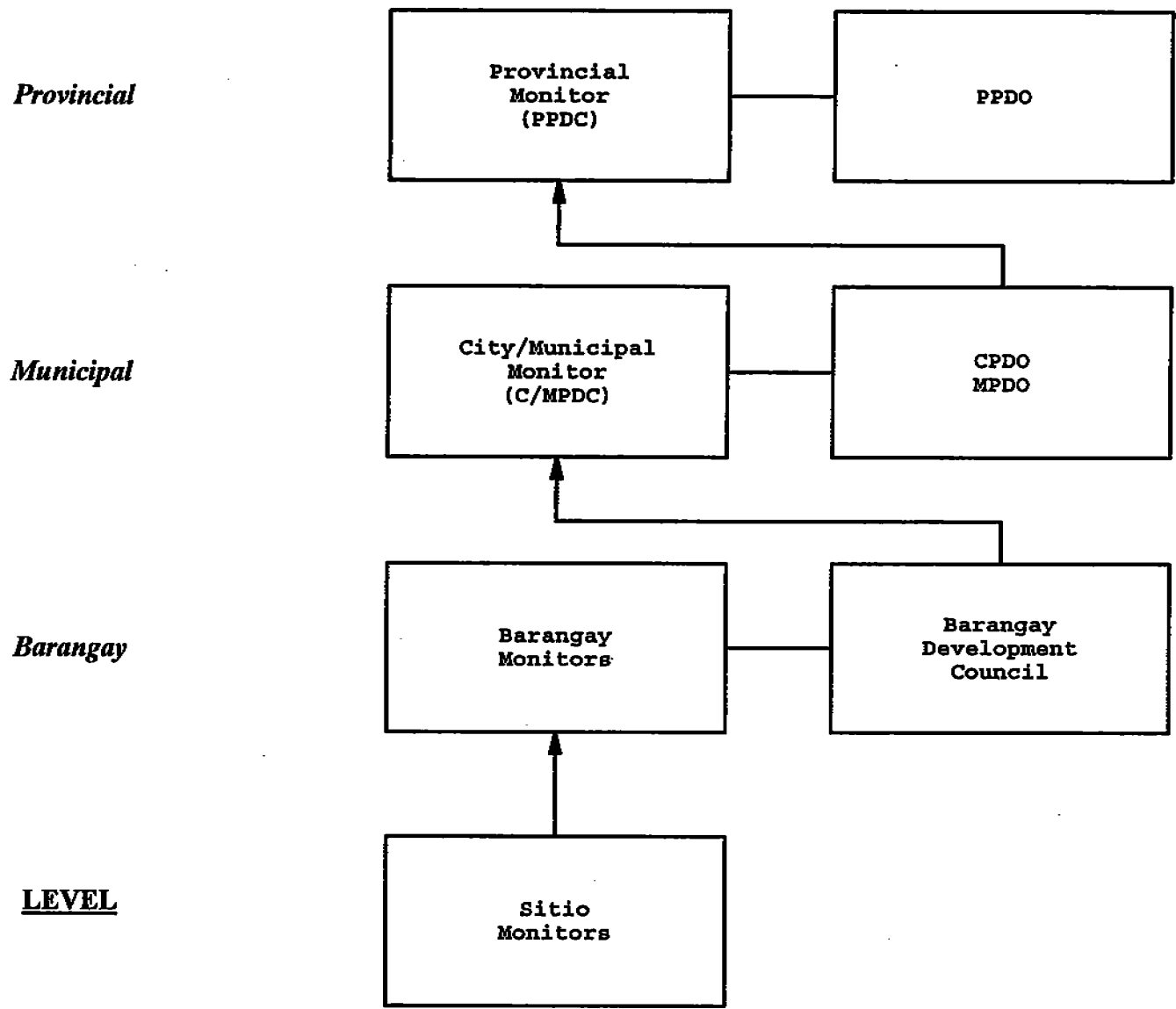

Figure 2

**VERTICAL FLOW OF INFORMATION: CBCMS**

### 2.3 Integrated Rural Accessibility Planning Project (IRAP)

**Background.** The Integrated Rural Accessibility Planning (IRAP) Project, which is a collaborative undertaking between the Department of Interior and Local Government (DILG) and the International Labour Organization (ILO), was initiated in October 1992 to address the problem of poverty as characterized by the isolation of the rural population from the mainstream of economic activity and their lack of access to essential economic and social goods and services. Two problems concerning the conventional approaches to improving accessibility have been identified:

- (a) Assessment of people's needs is based on standards specified by the central government, which do not necessarily reflect people's wishes.
- (b) Planning tends to be based on secondary data, thus reinforcing the remoteness of the planning process from the needs of the rural people.

**Objectives.** The IRAP approach aims to identify interventions and projects toward improving the living conditions in rural communities through an assessment of the rural households' access to basic goods and services. It also involves the selection and prioritization of the locations for the needed interventions and provides guidelines on the costing of the interventions.

**Coverage.** IRAP has already been pilot tested in seven provinces, and will cover a total of 18 provinces by October 1994. So far, Regions 6, 8, 10 and 11 have been covered.

**Indicators.** IRAP uses primary data to define the ease or difficulty of rural people in obtaining basic, social and economic services. Data are then aggregated to the next level to come up with Accessibility Indicators (AIs) that are used for prioritizing interventions in the sectors that IRAP covers. The indicators can be derived at four levels: barangay, municipal, provincial and national.

The data collected at the barangay level deals with eight basic services: (a) water; (b) fuel; (c) education; (d) agricultural inputs and outputs; (e) roads; (f) transport services; (g) markets; and (h) health.

The data relates to the number of households who need access to these services and the distance/travel time that it takes them to obtain the services. These are then translated into a composite AI relating to a specific sector and area.

**Monitoring System.** The IRAP approach is a month-long process that starts from the definition of the study area, training, data collection, data analysis, to the project identification phase. The total cost (excluding that for the technical personnel) for the entire province amounts to P250,000.00.

Data is collected at the barangay level from key informants such as teachers, elders and barangay council members. Data collection takes about half a day. From these data, the composite AI is derived.

The following outputs are generated by the system:

- (a) complete accessibility database for all barangays;
- (b) scale maps showing distribution of physical infrastructure and service facilities, population concentration, and natural endowments;
- (c) trained personnel at the MPDO and PPDO; and
- (d) prioritized access, disaggregated by barangay, municipality, and province.

**Evaluation.** The following are the strengths of the system: (a) considers all aspects of household access needs, i.e., subsistence, economic, and social; (b) simple and inexpensive to apply; (c) easily identifies interventions/projects at the local level; and (d) accessibility indicators are derived at all levels: barangay, municipal, provincial, and national.

On the other hand, the IRAP approach may generate inaccurate results. Data collection is done only for half a day during a meeting with key informants of the barangay. Moreover, the approach is unable to identify potential beneficiary households since individual household data are not collected. Furthermore, the focus is on "input" indicators and not "impact" indicators.

## 2.4 Review of Existing NGO Monitoring Systems

The following review of existing monitoring systems is based on information gathered for a number of NGOs based in Metro Manila, namely: (a) ABS-CBN Foundation; (b) Andres Soriano Foundation; (c) Ayala Foundation; (d) Council for People's Development; (e) Economic Development Foundation; (f) National Conference of Cooperatives; (g) National Council of Churches; (h) National Secretariat for Social Action; (i) Partnership for Philippine Support Services Agencies; (j) Philippines-Canada Human Resources Development Program; (k) Philippine Business for Social Progress; (l) Philippine Rural Reconstruction Movement; (m) Pilipinas Shell Foundation; (n) San Miguel Foundation; (o) Small Enterprise Research and Development Foundation; (p) *Tulay sa Pag-unlad*; and (q) UCPB Foundation. Initial findings indicate that, in general:

- Existing databases of NGOs cannot be used to test MIMAP hypotheses because of the absence of time series data on socio-economic variables. Only time series data on financial variables are usually available.
- Monitoring systems are project-oriented, i.e., mainly concerned with monitoring the status and success of their own programs and projects. Thus, the collection of data is coterminous with the lifetime of a specific program/project.
- Some NGOs are mandated by their sponsors to assist only specific groups, which are not necessarily disadvantaged groups.
- Most NGOs do not maintain their presence at the lower administrative levels, i.e., barangay and municipal.
- Data collected are usually used by project proponents only as feedback and for project planning.

During this initial assessment, focus was given to: (a) the Philippine Rural Reconstruction Movement (PRRM), because of its project that seeks to pilot-test a proposed model for a district-based information system with community sentinels; and (b) the Philippine Business for Social Progress (PBSP), because of the relevance of its objectives and target groups to MIMAP. The former will be discussed further in the succeeding chapter. The PBSP monitoring system merits a closer evaluation inasmuch as it seeks to view social development from a provincial and poverty-group perspective. Moreover, its target beneficiaries include marginal upland farmers, lowland

small farmers, small fishermen, landless rural workers, urban slum dwellers and cultural communities. Compared to other NGOs, it has a more sophisticated monitoring system and a larger database, particularly on its Provincial Development Strategy Project. Data is collected by provincial project officers through regular surveys or by regional research offices through special studies. Indicators on the following are gathered: (a) access to productive assets; (b) value formation/awareness; (c) economic activities; (d) access to basic social services; (e) access to strategic connections; and (f) infrastructure support. Annual project summaries are generated from these. Nevertheless, the monitoring system does not extend deeper than the provincial level which is a potential problem when institutionalization of the system is considered.

To supplement the review of existing monitoring systems initiated by NGOs based in Metro Manila, the MIMAP Project Management Office (PMO) visited a number of community-based monitoring areas outside of Metro Manila which are being implemented by NGOs. These project site visits included the following areas which are spin-offs of past projects that sought to establish community-based information systems: (a) New Bataan, Davao del Norte where the Grassroots Organization for the Welfare of New Bataan (GROW-New Bataan) Federation is implementing a Community Information and Planning System (CIPS) approach; (b) Barangay Tuban, Sta. Cruz, Davao del Sur where the barangay health data board, which was initially part of an effort to establish a Management Information System under the Community Health through Integrated Local Development (CHILD) Project in Region XI, is currently being maintained. In addition to these areas, the MIMAP PMO visited a project area in Gordon Heights, Olongapo City which is implementing a community-based monitoring system under the Olongapo Urban Basic Services Programme (UBSP). A section is also devoted to a discussion of a recent project entitled *Partnership Mechanism in the Management of Basic Health Care Programs and Services* under the Local Development Assistance Program (LDAP) which developed a community health information and monitoring system.

#### **2.4.1 Community Information and Planning System (CIPS)**

***Background.*** In 1983, an NGO study of selected villages in Southeast Asia was launched as a joint programme on rural community participation by the Center for Integrated Rural Development for Asia and the Pacific (CIRDAP) and the Asia NGO Coalition (ANGOC). The main objective of the programme was to obtain village-level data on the socio-economic conditions of the villages surveyed in six Asian countries, which included the Philippines. One of the main features of



this CIRDAP-ANGOC survey was that the data gathered by the local researchers were reported back to the villagers during community consultations, a practice that was seen lacking in conventional research. This became the beginning of the consciousness-building process as well as community planning using participatory research.

Based on the results of the initial study, another project called the Community Information and Planning System (CIPS) Phase I was initiated in 1984 covering 10 countries including the Philippines. The CIPS Program was implemented in 1984-86 in two pilot villages in the Philippines, simultaneously with 18 other villages in all participating countries.

The pilot test experience resulted in a modification and refinement of the CIPS model that became the basis for the expansion of CIPS to 22 communities in a project called "Participatory Research for Community Education Using the CIPS Methodology" which was supported by the International Development Research Centre. This Project, which was implemented in 1987-89, was assisted by various NGOs, namely: the Appropriate Technology Center (ATC); the Muslim-Christian Agency for Rural Development (MuCARD); the Institute of Primary Health Care (IPHC) of the Davao Medical School Foundation; the Visayas Cooperative Development Center, Inc. (VICTO); the Center for Community Services (CCS); and the Agency for Community Education and Services (ACES).

*Objectives.* The main objectives of the CIPS Project were to assist various kinds of communities to solve specific self-identified problems through the use of a participatory research and planning system and to provide the NGO community an opportunity to develop appropriate participatory research models. Specific objectives at the community level were to:

- (a) Establish a community information and planning system (CIPS) to identify and solve specific community problems;
- (b) Investigate the causes and consequences of the problems identified through the collection and analysis of data;
- (c) Organize and operate community planning and implementation committees and processes to follow-up on research recommendations; and

- (d) Monitor and evaluate the projects and activities with respect to the degree participation of the community members, the benefits derived and the equity of distribution of benefits and responsibilities.

**Coverage.** In this network project, six different NGOs affiliated with the Philippine Partnership for the Development of Human Resources in Rural Areas (PHILDHARRA) coordinated the implementation of the CIPS model in various communities. ACES covered 4 communities in Central Luzon; CCS, 2 urban communities (Camarines, Novaliches); VICTO, 6 communities and 2 cooperatives in Cebu; ATC, 4 communities in Mindanao; MuCARD, 2 communities in Mindanao; and IPHC, 3 communities in Davao. A total of 21 communities were covered by the Project.

**Indicators.** The communities involved did not collect a prescribed set of indicators but rather decided on specific indicators that need to be collected to address its needs.

**Monitoring System.** The NGOs defined what constituted a community for the purposes of research. They assisted the communities in organizing village committees that will oversee the Project and elect the fieldworker who will act as the community catalyst. They facilitated the formation of a local research group, known as the "core group," which were trained in simple data collection and analysis techniques. Data collection by the core group generally involved such tools as mapping, local histories, price monitoring, sociogram construction, and record/journal keeping. Data were posted in public places and presented using graphics and percentage calculation. The core group presented the results to the community through a community consultation. During this consultation, the community members examined the data critically. At that point, a planning committee was constituted. After receiving training in planning techniques, this committee formulated the details of an implementation plan. After review at another community consultation, the plan was turned over to an implementation committee which would execute a plan. Project planning and implementation activities were monitored by the core group. The committees, with the help of the proponent NGO and fieldworker, did the evaluation.

**Evaluation.** CIPS has been endorsed as a development approach but the core of CIPS is that it is a village-level information system. The main feature of this type of information system is that through participatory research, the community generates the information that

they need for decision-making, planning, and plan implementation. It relies on some community members to gather information and make preliminary analysis and recommendations but the village consultations provide the mechanism for the community to "clean" the data. The community documents its experiences through research and progress reports and displays their data on bulletin boards or flip charts that show the actual community situation.

One of the problems concerning the introduction of CIPS into the community is to make the villagers realize that they have to work hard to reap the benefits, not necessarily material, that CIPS will bring to them. Sometimes, it may also be frustrating for the community, and even the NGOs, when feedback on action on their project proposals takes a long time. Furthermore, since the CIPS approach requires community organizing methodologies, its success depends largely on the NGOs and POs that act as community catalysts.

The MIMAP PMO recently visited a project area in New Bataan, Davao del Norte. The monitoring system, which is currently being implemented by the Grassroots Organization for the Welfare of New Bataan (GROW-New Bataan) Federation, is a spin-off of the original CIPS Project. The Federation consists of 5 peoples' organizations (POs). The sustainability of this system over the past few years is mostly due to the presence of these NGOs that employed community organizing/participatory action research techniques. However, local researchers work voluntarily so that appreciation of the significance of the work is critical and possibly some form of incentives to these researchers must be provided to ensure its sustainability.

#### **2.4.2 The Community Health through Integrated Local Development (CHILD) Project in Region XI**

*Background.* The CHILD Project was conceived in 1985 during one of the meetings of the Health Subcommittee of the Regional Development Council (RDC). The Subcommittee then was composed of government and NGOs involved in health services delivery. The group expressed the need for a regional health monitoring system that is accurate, reliable, effective and efficient. The rationale behind this concern was that health information was badly needed to plan and develop health programmes responsive to the needs of the majority. Some of the data problems cited were parallel but conflicting sets of data from several agencies and double counting. Thus, the initial

concept paper of a simple community health information development project written by the Davao Medical School Foundation-Institute of Primary Health Care (DMSF-IPHC) which was to be implemented in a small number of communities developed into a bigger project covering the whole region and included other major components.

**Objectives.** The main goal of the CHILD Project was to reduce infant and young child mortality in selected communities in Southern Mindanao (Region XI). The attainment of this goal was viewed as dependent on the success of three component sub-projects, namely: Health Services Delivery, Local Development, and Community Participation. The Project started in August 1986 and ended in August 1990 and was funded by the USAID.

**Coverage.** The CHILD Project initially covered 286 project communities in 188 barangays in 30 municipalities in 5 provinces and in 2 cities of Region XI. A community with 150 households was considered one project community. 31 project communities dropped out due to problems of inaccessibility as a result of the worsening condition of the road network, and the worsening peace and order situation. The programme covered 46,573 families with a total population of 240,317.

**Indicators.** The following are the components of the MIS:

(a) Baseline/annual health information report

This report captures the following data of the families covered by the Project: number of births and distribution by sex, number of deaths and distribution by age-group and cause, type of human waste disposal, type of garbage disposal, type of sewage disposal, quality of the source of drinking water, nutritional status of children under five, immunization status of children under one, immunization status of pregnant women, methods of birth spacing used by MCRAs, and utilization of prenatal services.

(b) Quarterly health information report

The following information are derived from this report: type of human waste disposal, quality of the source of drinking water, nutritional status of children under five, immunization status of pregnant women and

utilization of prenatal services, and method of birth spacing used by the MCRAs.

(c) Under-six masterlist

The BHWs maintained this masterlist of children under six years of age. This contains information on the immunization and nutritional status of the children.

(d) Community data board

The community data board shows the map of the community with all the landmarks such as roads and rivers, churches and school buildings. The information contained in the data board is the same as those captured in the quarterly health record. The data board facilitated the identification of at-risk families on a map, the prioritization of targets for health delivery services, and the rapid assessment of the delivery of basic health services by simply looking at the predominant color of a specific indicator. This tool was also adopted in the establishment of a community health information and monitoring system under the LDAP Project discussed in the succeeding section.

The type of indicators monitored quarterly were not consistent. It varied from year to year or from community to community, depending on the prioritized problems of the community.

**Monitoring System.** The relevant monitoring system was subsumed under sub-project 3 or the Community Participation component in which the principal implementor was the IPHC. The objective of this sub-project were: to organize and enable project communities to identify and prioritize their problems/needs; to plan and implement projects to answer these problems/needs; and to monitor and evaluate changes in the status of these problems/needs as a result of the intervention.

To attain these objectives, the following activities were undertaken: CHILD Project orientation; training of barangay health workers and barangay secretaries on the Management Information System (MIS); training of barangay health workers (BHWs) and other members of the cluster planning team on community diagnosis;

presentation of the results of the baseline survey or community diagnosis to the cluster members; training of BHWs and other members of the cluster planning team on project planning, implementation, monitoring and evaluation, and project proposal writing; community and resource mobilization; establishing linkage with at least two agencies; project monitoring and community reflection; evaluation of the health status of the community based on the results of the quarterly and annual surveys; re-planning, implementation, monitoring and evaluation; and continuing education of BHWs and barangay leaders based on identified training needs.

The MIS is a system of continuous data gathering and analysis for the identification and prioritization of community problem, effective and efficient planning, and for the monitoring and evaluation of programmes/projects. This served as a tool for increasing people's awareness of their own situation and their capability to improve the quality of their own lives.

About 3,113 BHWs were recruited under the Project. In most project communities, BHWs were elected by their cluster members during the purok/sitio level orientation. The average ratio of BHW-to-number of families in June 1990 was 1:17 (ranging from 1:5 to 1:42). These BHWs were responsible for the installation and the regular updating of the MIS in their areas. They received two-to-three days training from the Project Officers, with the assistance of the Rural Health Midwife (RHM) and the Rural Sanitary Inspector (RSI).

*Evaluation.* The CHILD MIS underwent several changes during its project life. The original purpose of the MIS was to generate accurate information for the use of social development agencies as basis for their programme planning and evaluation. Towards the second year of the Project, there was a gradual shift in the intention of the MIS from agency-use to community-use. The MIS was then marketed as a tool for increasing the social awareness of cluster members on their health status and what they can do to improve it, and as a basis for project planning and evaluation.

There were very apparent effects of the MIS. In many instances, it motivated the households to change the red (or negative) indicators reflected on the house-cut-outs of the community data board to green (or positive). To a certain degree, it eliminated duplication of services being covered by various agencies, e.g. provision of supplementary feeding by the DOH, DSWD and the Catholic Relief Services. Furthermore, identification of at-risk families by service

providers was made easier.

However, the problem of inconsistent data among various agencies could not easily be resolved. In some cases, the BHWs could not cover the whole barangay so that the data did not match those of other agencies. Moreover, institutionalization of the system depended highly on the appreciation of the BHWs, barangay officials, as well as the general public of the use of the system in community planning and evaluation.

In a recent visit by the MIMAP PMO to Barangay Tuban in Davao del Sur, where a community health data board is being maintained, it was observed that community members were very enthusiastic in showing off the information system. However, the attitude that the MIS, particularly the community data board, is for agencies and visitors has to be overcome. Furthermore, the present system of updating the data board results in the loss of information concerning the previous periods. Thus, no time series data are maintained. In addition, the data collected are not stored centrally and instead are recorded in notebooks kept by the monitors.

#### **2.4.3 Partnership Mechanisms in the Management of Basic Health Care Programs and Services**

*Background.* In 1992, more than 30 NGOs/POs received a grant from the USAID thru the Local Development Assistance Program (LDAP) of the Philippine Business for Social Progress (PBSP). The fund was intended to support the different NGO/PO initiatives in line with the implementation of the Local Government Code. The Institute of Primary Health Care (IPHC), being the service arm and one of the operating units of the Davao Medical School Foundation which implements health and other social service projects in selected areas in Region XI in coordination with various government agencies, was one of the recipients of the said grant.

*Objectives.* The LDAP-IPHC project, "Partnership Mechanism in the Management of Basic Health Care Programs and Services" was implemented by the IPHC in collaboration with the NGOs and LGUs, particularly the Municipal Health Office (MHO). The Project aimed at improving the health delivery system especially in marginalized communities. Specifically, the Project sought to:

- (a) Facilitate the active participation of the private sector,

particularly NGOs which are involved in health-related services, in the basic health care delivery system;

- (b) Reactivate and strengthen the Local Health Board and Health Development Councils;
- (c) Establish a health care monitoring system and draw a health profile of the target areas;
- (d) Devise self-sustaining health financing schemes that can complement the LGU/MHO medical subsidies;
- (e) Increase the target beneficiaries' awareness on health and sanitation through information, education, communication, and motivation (IECM); and
- (f) Activate the Barangay/Municipal Health Stations and mobilize the Barangay Health Workers.

**Coverage.** The Project was pilot tested in one municipality in Davao del Norte, and another in Davao del Sur, initially covering 10 barangays in each municipality. However, the Project benefited not only these barangays but the entire municipalities as representatives from non-LDAP barangays were also invited to attend the trainings and participate in the project implementation.

**Indicators.** The indicators used in the community health information and monitoring system cover the following areas of concern: (a) nutrition; (b) immunization; (c) family planning; (d) pregnancy; (e) water source; (f) toilet; (g) drainage; and (h) garbage disposal.

**Monitoring System.** One important scheme that has been developed in the course of the project implementation, which follows the approach of participatory-action-research (PAR), is the community health information and monitoring system. This may be described as the process and the procedures and guidelines which a certain community follows as it generates its own health data and monitors its own health conditions.

The process flow is as follows:

- (a) Decision of the BHWs and barangay officials to assess and improve the health status of their barangay;
- (b) Formulation of the health survey questionnaire;



- (c) Actual conduct of the survey by the BHWs;
- (d) Presentation of the survey results to the community through an assembly meeting and through the barangay health data board;
- (e) Health planning;
- (f) Formulation of the monitoring and evaluation tools based on the health plan;
- (g) Conduct of the Quarterly survey to assess the health situation;
- (h) Updating the health data board; and
- (i) Health plan assessment and action planning.

The following are the guidelines and procedures:

- (a) The community health data board must be installed in strategic places in the barangay, such as in the barangay hall, purok center, health station or other meeting places.
- (b) Standard color codes are used for each health variable/indicator.
- (c) If possible, a standard health survey form should be formulated for the use of all barangays.
- (d) Health monitoring should be done quarterly.
- (e) Monitoring teams should be formed which should not be composed only of BHWs and barangay officials but also of representatives from the Local Health Board, MHO or the Sangguniang Bayan.
- (f) A year-end health assessment may be conducted to evaluate the overall implementation of health programs/projects. The result of this activity may be used as basis in preparing the annual health plan and budget.

The following monitoring tools are used: (a) the barangay health data board; the health survey form; and the health monitoring and evaluation form.

The community (or barangay) data board shows the map of the community with all the landmarks such as roads and rivers, churches and school buildings. The central focus of the map are the houses of the residents. These cut-out houses contain symbolic drawings signifying such data as morbidity, the social and political status of the family head or his wife, and key health indicators. The data board facilitates the identification of at-risk families on a map, the

prioritization of targets for health delivery services, and the rapid assessment of the delivery of basic health services by simply looking at the predominant color of a specific indicator. Annex C shows how the data/indicators are presented and color-coded in the community data board as lifted from *A Manual: DMSF/IPHC-LDAP Experience (1993)*.

The health survey form is designed to allow the quarterly entries of health data. Only one survey form can be used repeatedly for a family for one whole year. Updated once every three months, the data on the survey form become the basis for all entries in the barangay data board.

The health monitoring and evaluation form is used in monitoring and assessing the extent to which the barangay health plans have been implemented. It contains comparative data between targets and actual accomplishments and may be used as basis for annual health planning and re-programming.

The role of the BHWs is to monitor the health status, inspect the sanitary condition of their respective areas and to gather, collate, summarize and analyze health data, before submitting their monthly and quarterly reports to the Barangay Development Councils (BDCs) and to the BHW Federation. The BDCs, on the other hand, see to it that the BHWs are provided with the necessary support so that the latter can work effectively. When the required financial assistance cannot be met satisfactorily using the barangay funds, it is the role of the BDCs to ask for financial aid from the Municipal Development Council or from the NGOs.

***Evaluation.*** In support of the Local Government Code, the Project provided the mechanism for the cooperation of the LGUs with NGOs and POs in local governance as well as in the delivery of basic health services. It reactivated and mobilized the mass-based BHW associations/groups which are considered vital in improving the health care delivery system. Prior to the implementation of the Project, the monitoring and assessment of the health condition of the locality was solely the task of midwives and sanitary inspectors.

On the other hand, some problems were experienced in the implementation of the Project. One, some LGUs had difficulties realigning/allocating funds for the implementation of the Health Plan generated by the LDAP Project. Two, there was lack of support of some LGUs to BHWs. Three, there were insufficient training funds for non-LDAP barangays. Finally, sustainability of the BHW

groups/associations and of the established health information and monitoring schemes was difficult especially in areas where there is lesser cooperation and support from the Barangay Councils concerned.

#### **2.4.4 Community-Based Monitoring under the Urban Basic Services Programme**

**Background.** One of the major programmes under the Programme of Cooperation for Children, 1994-1998, which is jointly being undertaken by the UNICEF and the Government of the Philippines, is the Integrated Rural and Urban Basic Services (IRUBS). Through IRUBS, it is expected that disparities within and among provinces and cities will be reduced. This is composed of three projects: building the capability of LGUs for Child Survival, Protection and Development (CSPD) toward meeting the goals of the Philippine Plan of Action for Children; rural integrated services aimed at reducing disparities; and urban basic services.

**Objectives.** The UBSP strategy is strongly rooted in the government's overall approach to reducing poverty. UBSP, for 1994 to 1998, seeks to promote convergence of services to poor children, women, families and communities. UBSP aims to promote, for all children, universal coverage of key services including health, nutrition, water and sanitation, child development, child protection for street children, working children, disabled children, children in situations of armed conflict, child victims of natural disasters and other categories of children in especially difficult circumstances. UBSP will sharpen its focus on empowering the poor to participate in their own development through support activities such as community organizing, training, and capacity-building, advocacy, social and resource mobilization and networking, research, monitoring and evaluation.

**Coverage.** UBSP, for 1994 to 1998, shall cover 14 cities and 13 municipalities with a combined population of approximately 11.4 million or 39% of the total urban population.

**Indicators.** The CBM, in general, collects data on the situation of the community, particularly that of women and children, and on community services including inputs and outputs of community-initiated projects and activities. Indicators collected, however, are community-specific and may cover the following areas of concern: (a) health and nutrition; (b) water and environmental sanitation; (c) education; (d) livelihood; (e) family planning; (f) housing and land tenure; and

(g) services for street children.

**Monitoring System.** In the process of implementing the UBSP, particularly in Olongapo City, which the MIMAP PMO visited, a community-based monitoring (CBM) system has been established. Prior to the actual implementation of the CBM, the community undergoes an organizing process. This includes: the community-specific design of the CBM; the orientation of the community on the CBM; the orientation of the community leaders on the CBM; the selection of monitors; the identification of indicators; the training of monitors; the clustering of families; spot mapping; and the selection of cluster leaders. Actual monitoring includes the activities presented in Figure 3. Three forms are used, namely: Form A, where the raw data is entered as the community monitors interview respondents; Form B, where the data in Form A is summarized; and Form C, which summarizes the Form B submitted by monitors to the overall community monitor.

**Evaluation.** The CBM system provides for the development of the capability at the community-level to generate the relevant information and use these for development planning. However, it was observed by the MIMAP PMO during its visit to a project area in Gordon Heights, Olongapo City, that problems emerge because the clustering of families into project areas does not coincide with the barangay. Thus, the concerns of the community may run into conflict with the interests of the barangay. Furthermore, although the monitoring system is very useful for the community in identifying the needed projects, the community still relies on the help of the NGOs to secure resources from the government and international donors.

Figure 3  
COMMUNITY-BASED  
MONITORING SYSTEM  
UNDER UBSP

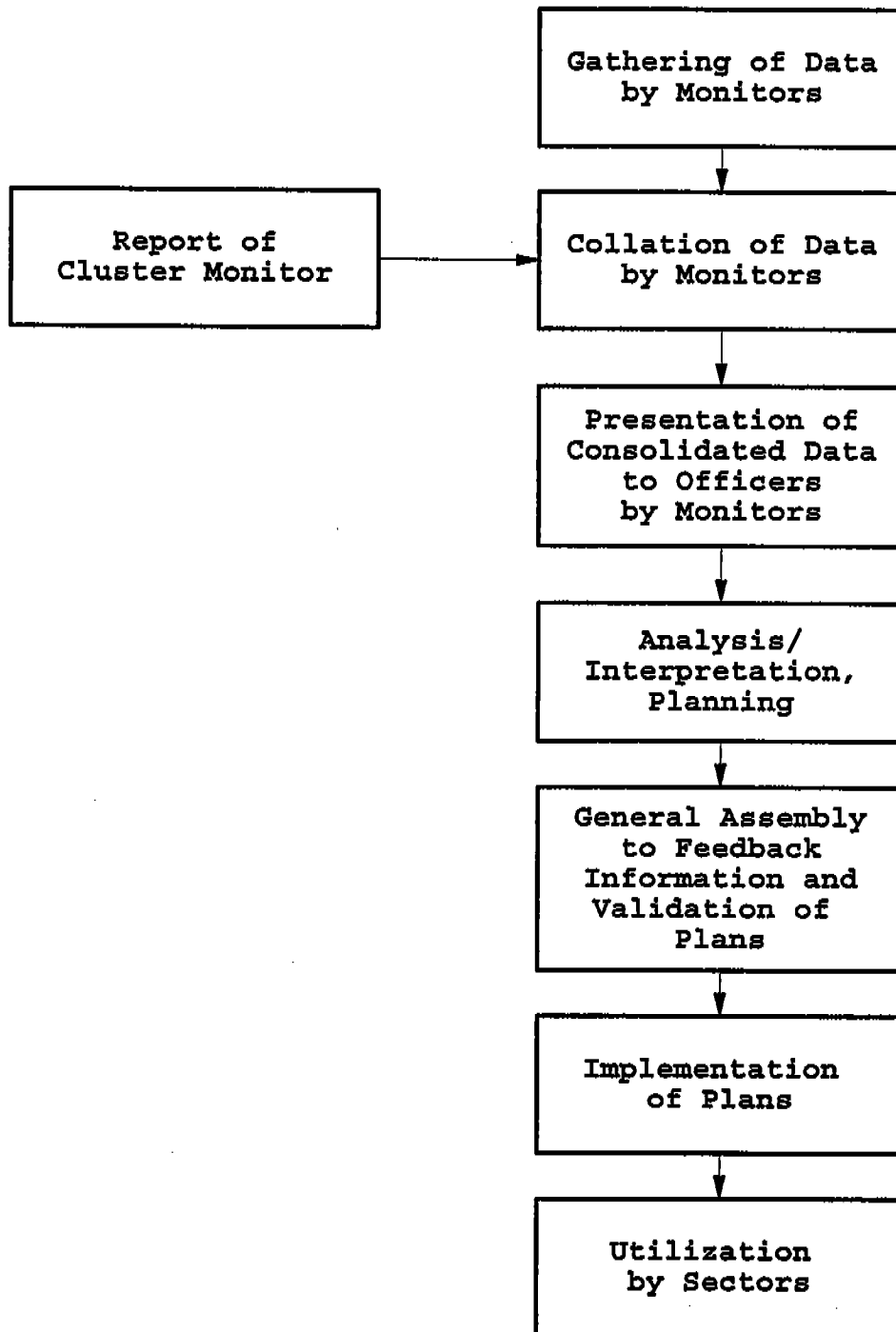

### 3. INVENTORY AND REVIEW OF PROPOSED MONITORING SYSTEMS

This chapter covers an assessment of proposed monitoring systems, namely: the Social Welfare and Community Development Indicator System; the Community-Based Information System to be used for monitoring and evaluating the Philippine Plan of Action for Children; and the District-Based Statistical and Information System with Community Sentinels. As in the previous chapter, this assessment involves: (a) a review of the objectives, coverage, indicators, and the mechanism by which data are proposed to be collected, processed and analyzed; and (b) an evaluation of the strengths and limitations of each monitoring system.

#### 3.1 Social Welfare and Community Development Indicator System (SWCDIS)

**Objectives.** The SWCDIS Project was jointly initiated in 1991 by the NSCB and the Department of Social Welfare and Development (DSWD) to address the need for a statistical system for the Social Welfare and Community Development sector. The SWCDIS is an integrated data system intended to monitor the changes in the quality of life of the economically and socially disadvantaged population. The Project specifically aims to:

- (a) develop a framework necessary for assessing and monitoring the situation/conditions of the poor at the national and local levels;
- (b) assess data availability, data sources, and data gaps;
- (c) recommend a feasible system of regular provisions of database and production of statistics and indicators; and
- (d) develop an operations manual to guide implementors in the operationalization of the SWCDIS.

**Coverage.** SWCDIS shall seek to monitor the economically and socially disadvantaged population. The criterion to be used for selecting the sample would be households falling below the poverty (food) threshold. DSWD is initially planning to undertake a poverty mapping covering 27 provinces.

**Indicators.** The identification of the indicators for the monitoring system was generally guided by the conceptual framework that consists of four major components, namely: (a) status and conditions; (b) programs and services; (c) resources; and (d) environment. These components are further sub-classified into ten factors. These comprise the statistical framework of the Indicator System, namely: (a) income and livelihood; (b) health; (c) food and nutrition; (d) clothing; (e) water and sanitation; (f) housing and shelter;

- (g) peace and order / public safety; (h) basic education and literacy;
- (i) psycho-social/family care; (j) participation and community life.

The Indicator System consists of a total of 30 indicators classified under the factors mentioned above. The SWCDIS covers all the areas of concern of the MBN Indicators, and further includes psycho-social and family life. (See Annex D for the list of indicators).

**Monitoring System.** The operational framework for the SWCDIS consists of a network of agencies and institutions at the national, regional, provincial/city, municipal, and barangay levels which are involved in the provision of social welfare and development services and in the monitoring of the changes in the quality of life of the disadvantaged population.

Figure 4 presents the SWCDIS information flow while Figure 5 presents the monitoring activities and the respective agencies responsible for such activities. As these figures show, the local government offices (municipal, city, and provincial levels) play a major role in data collection, data processing, data analysis, consolidation of reports, maintenance of the data bank, and information dissemination. (See Annex E for the list of agencies involved in the social welfare and community development sector).

The SWCDIS is expected to generate: (a) annual situational reports; and (b) databases at the various administrative levels.

**Evaluation.** This monitoring system has two major advantages: (a) the design of the system is a product of an inter-agency effort; and (b) the operational framework consists of agencies that are actually involved in the delivery of social services and the monitoring of the poor.

However, the proposed system has not been pretested yet. The reliance on administrative reports as data source for some of the indicators will mean uneven time period coverages. Some indicators will be up-to-date while others may have a lag of two to three years. Moreover, the establishment of the database does not go down to the barangay level.

SWCDIS acknowledges the multi-dimensional nature of welfare status by using 30 indicators covering various areas of concern. And yet, it chooses its sample households based on income alone. This drastically alters the definition of "economically and socially disadvantaged" population.

**Figure 4**  
**SWCDIS INFORMATION FLOW**

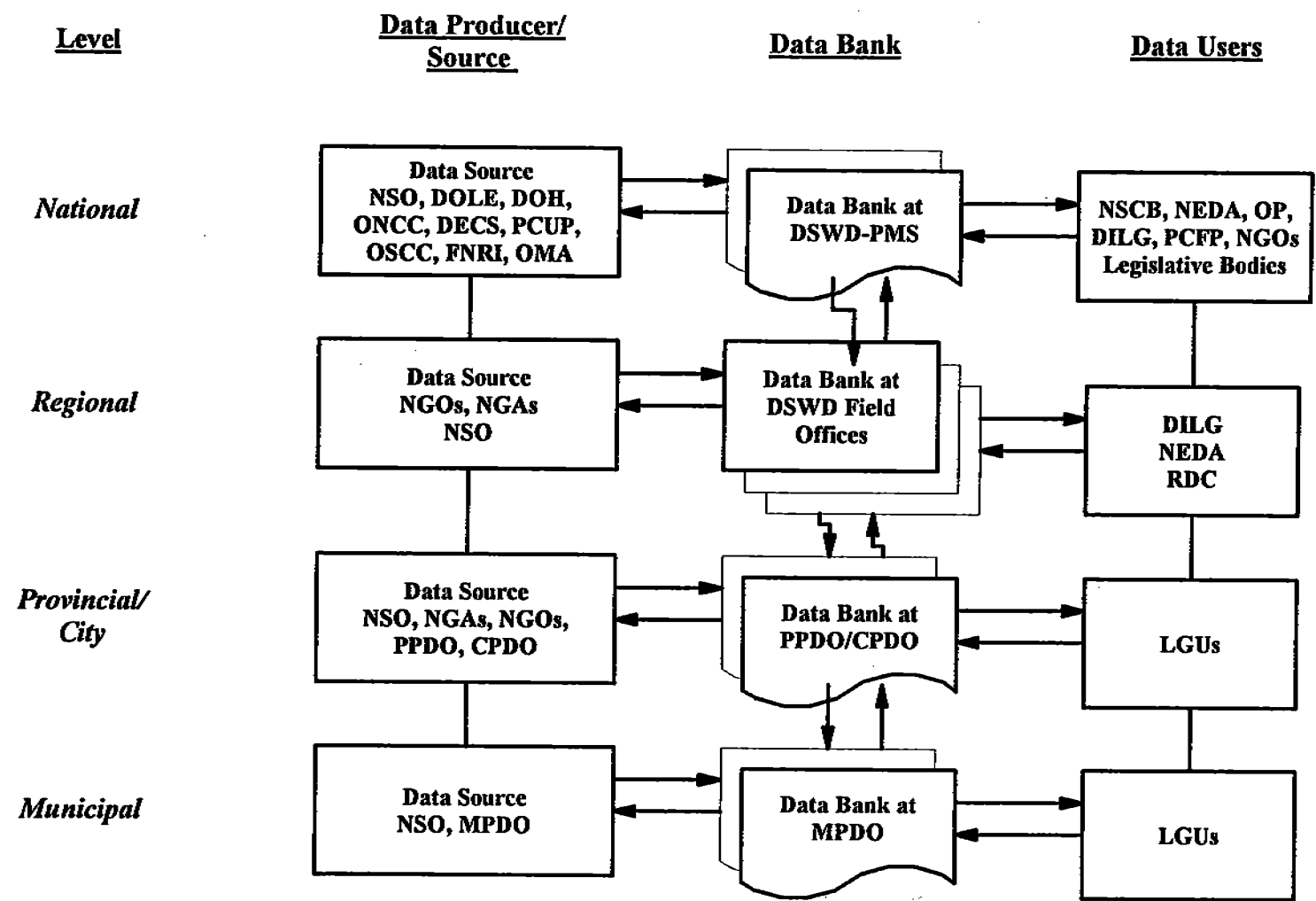

**Legend:**

- ==== Coordination
- ====> Data/Information Flow
- ====< Feedback



Figure 5

**SWCDIS MONITORING ACTIVITIES, BY AGENCY**

<u>LEVEL</u>	<u>DATA COLLECTION AND PROCESSING</u>	<u>INDICATOR COMPUTATION/ ANALYSIS</u>	<u>DATA CONSOLIDATION/ DATA BANK/ DISSEMINATION</u>
<i>Municipal</i>	MPDO	MPDO	MPDO
<i>Provincial/ City</i>	PPDO CPDO	PPDO CPDO	PPDO CPDO
<i>Regional</i>	NGA Field Monitoring Offices	NGA Field Monitoring Offices	DSWD Field Offices
<i>National</i>	NGAs	DSWD Planning & Monitoring Service	DSWD Planning & Monitoring Service

### 3.2 Community-Based Information System (CBIS) and Local Information System (LIS) for Monitoring and Evaluating the Philippine Plan of Action for Children (PPAC) Goals

**Background.** The Philippine Plan of Action for Children (PPAC) was formulated in 1993 in response to the World Summit Declaration and Plan of Action for Children, which the Philippine government committed to in 1990. PPAC identifies specific goals and targets for sustaining and promoting the well-being of Filipino Children. Serving as catalyst for PPAC is the Programme of Cooperation for Children (CPC) between the Government of the Philippines and UNICEF. This Programme outlines specific objectives relating to the areas of child survival, protection, and development (CSPD) and the promotion and monitoring of PPAC and CPC. One of these objectives is to establish and implement barangay, municipal, and provincial systems for monitoring PPAC goals and stimulating community, NGO, and private sector support for these goals. To help achieve this objective, the Center for Policy and Administrative Development of the U.P. College of Public Administration has designed CBIS, which is basically supported by LIS. The proposed CBIS is a module of the *Handbook for Local Government Units on the Integrated Approach to Local Development Management (IALDM) for PPAC* which is to be implemented within the context of the Local Government Code.

**Objectives.** The CBIS is an information system installed and maintained at the barangay level by representatives of people's organizations (POs). It specifically aims to:

- (a) generate information needed for effective management of programs/projects undertaken by POs;
- (b) promptly inform the people of the situation in their community and thereby encourage them to take corresponding actions;
- (c) ensure that the information needed in the different management processes for the IALDM are reliable, accurate, relevant and timely; and
- (d) promote sharing of information among various sectors not only at the barangay level but also at higher levels of local government.

The LIS, on the other hand, is an information system for the various PPAC services, and other local development programs established and maintained by the LGUs at the municipal, city, and provincial levels, and by the regional government in the case of autonomous regions. It seeks to:

- (a) ensure that reliable, accurate and relevant information are available in a form and at a time needed by local officials for decision-making;
- (b) provide information on the situation of women and children on services being delivered or availed of, and their impact;
- (c) encourage planners, implementors, monitors and evaluators to be more rational and realistic in performing their respective program functions; and
- (d) generate, among beneficiaries, an awareness of their situation and encourage them to avail of services or take actions to improve their status.

**Indicators.** The CBIS and the LIS are expected to provide information on the status of community residents in terms of MBN standards, and other important information about the community. The IALDM has identified the MBN for PPAC. These cover the areas of (a) survival--maternal health, child health, adequate nutrition, water and sanitation; (b) protection --security and safety, and housing; and (c) enabling activities--education, livelihood/income, and participation. The MBN are translated into 19 goals or desired outcomes. Except for the peace and order sector, the MBN for PPAC closely corresponds to the MBN as drawn up by the inter-agency group for the Presidential Commission to Fight Poverty (PCFP). (See Annex F for the list of indicators).

**Monitoring System.** The CBIS is expected to be established and maintained by representatives of POs with the help of GO and NGO frontline workers in the barangay. Thus, a prerequisite for the installation of the CBIS is community organization. For community-based barangays, i.e., those with active POs, focus should be on establishing a CBIS group composed of PO representatives. For community-oriented barangays, i.e., those without active POs, emphasis should be on tapping the program-based volunteers, community leaders and residents for the establishment of a multisectoral databank which will eventually form part of the CBIS.

On the other hand, the first step in the installation and maintenance of LIS for PPAC is to appoint or designate a Local Information Officer. The Local Government Code stipulates that an information officer may be appointed for the provincial, city, and municipal governments. If the LGU does not intend or cannot afford to hire one, it may designate the Local Planning and Development Coordinator to concurrently serve as the information officer since one of his regular functions is to monitor and

evaluate the implementation of local development programs, projects and activities. The LIS should utilize the existing information systems of other LGUs and sectors at various levels, including the CBIS or the multi-sectoral databank at the barangay level, and in turn, allow other LGUs and sectors to use the information that the LIS generates.

*Evaluation.* The strengths of the system include the following: (a) puts to practice the local government code of decentralization; (b) uses the MBN concept; and (c) utilizes existing information systems and will, in turn, allow other LGUs and sectors to use the information that CBIS and LIS generate.

The system, however, focuses only on women and children. It might take some time to institutionalize it because the proposed system has not been pretested and it requires organized POs for the success of the approach.

### **3.3 District-Based Statistical and Information System with Community Sentinels.**

*Background.* In response to the need for comprehensive, updated, and accessible information for local development planning and policy-making, a three-phased project, Decentralization and the Philippine Statistical System, was sponsored by the Congressional Planning and Budget Office, in cooperation with the NSO and the Philippine Rural Reconstruction Movement (PRRM). The main goal of the Project is to formulate a set of recommendations for improvement in the PSS to make it more responsive to the requirements of decentralized development planning, policymaking and decision-making. Specifically, the Project aims to:

- (a) determine the optimal structural option for the PSS so that it can provide information in support of development planning, policy formulation, and decision making in the national and local governments;
- (b) review the statistical production system at the regional and provincial levels and pilot a system for data processing and dissemination at the provincial level; and
- (c) pilot-test a proposed model for district-based statistical and information system with community sentinels for local use and its linkages with the PSS.

*Objectives.* The third specific objective above corresponds to Phase III of the Project, which is being implemented by PRRM. This Phase involves the development and installation of a district-based but community-anchored (through community sentinels) statistical system which will be capable of generating needed information and regularly monitoring change for input to the decision-making and planning activities of the community and other information users. The specific objectives of Phase III are to:

- (a) develop the framework for a community-ran data generation, processing, and retrieval system which will provide residents with a mechanism for accessing needed internal and external information;
- (b) install the data base management system in three pilot villages representing a district in each of the three provinces;
- (c) train the residents of the pilot villages in data gathering, processing, analysis and dissemination;

- (d) develop an efficient, viable and practical system for integrating data at a higher level of consolidation and for communicating processed and externally-generated data to the villages;
- (e) determine conceptual and operational considerations which will affect nationwide implementation of the Project, through the piloting of the system in the three provinces; and
- (f) generate inputs for the development of a framework for a nationwide information/networking system.

**Coverage.** The system was pilot-tested in three barangays in each of the following provinces with PRRM branches: Nueva Ecija, Negros Occidental, and North Cotabato, for a total of nine villages. Each group of pilot villages is expected to represent a district level distribution within the province. The selection of the provinces was based on the following considerations:

- (a) a representative site from each of the three main island groupings; and
- (b) diversity and representativeness of the various socio-economic systems and geographic characteristics prevailing in these areas.

**Indicators.** The needs of the communities will be given top priority, which include: credit sources, technology, land utilization patterns and options, prices of inputs and produce, markets for produce, work opportunities, and health facilities. These are primarily for short-term decision making.

PRRM likewise conducts social investigations to develop profiles of the intervention areas. The information blocks developed for the areas cover various aspects ranging from physical and demographic characteristics to its economic and social profile. Since most of these data can be generated from secondary sources, data gathering under the Project will focus on the people's perceived community problems, and consequently, the information needed to solve these problems. Thus, the priority variables will vary from one community to another. These priority information needs will be identified in the needs assessment stage.

**Monitoring System.** The district-based statistical and information system will contain both internally-generated and external information. Data generation will be done by the village residents themselves for concerns which need rapid assessment and early warning. Basic sectoral units (BSUs) or "self-help groups", composed of 15-30 members with representatives from each household, will be organized by PRRM. These people will be tapped as enumerators. In addition, the system shall have access to other data from

censuses and other surveys from the traditional sources that the community may need for planning and project formulation.

Two levels of statistical system are expected to be established: (a) community-ran data generation system, with PRRM's community organizers acting as catalysts inside the community; and (b) system linking the communities, the PRRM branch, and the Central Office units and the NSO municipal and provincial units.

Data shall be processed manually at the community level, while computerized processing will be utilized at the higher level. To allow the provincial offices of the NSO to have access to the information, the computers at the PRRM branches shall be linked to the NSO. Biweekly reports will be generated by the community organizers and discussed at a biweekly fora.

*Evaluation.* As in the other monitoring systems, this district-based system puts to practice the local government code of decentralization. It involves community participation and organization in all aspects of the system. The Project is ensuring the viability of the system through pilot testing before its eventual installation. One other advantage is that it shall link the entire system within PRRM, and with NSO. Furthermore, expansion of the Project will eventually lead to the establishment of a nationwide network of NGOs and the NSO local units.

On the other hand, the success of the system will depend largely on the degree of community organization and the presence of NGOs in the community. Moreover, the system has not specifically identified the monitor to be utilized.

#### 4. THE PROPOSED MIMAP COMMUNITY-BASED MONITORING SYSTEM

This chapter suggests some modifications in the monitoring system proposed by Florentino and Pedro under the MIMAP Phase II Project. Some issues related to the design of the monitoring system are also discussed.

Florentino and Pedro identifies the following as the basic elements of the MIMAP Monitoring System:

- Focuses on poor households and disadvantaged population groups.
- Disaggregates the collected information into functional groups.
- Adopts the concept of mobilizing and developing the capability of communities for data generation and utilization.
- Reports the data collected to the next higher geopolitical level for immediate intervention to address welfare gaps among the vulnerable groups, and ultimately reaching macroeconomic planners in order to influence adjustment programs.
- Creates and maintains the MIMAP data banks at each geopolitical level.
- Utilizes the information generated by monitoring systems already in place as support indicator system.

#### Issues

While the basic features of the MIMAP Monitoring System have been outlined by Florentino and Pedro, there are still some issues that have to be resolved.

*What kind of data should be collected?* The data collected should be able to provide reliable information on the welfare conditions of the vulnerable groups.

There are issues related to the measurement of welfare status. One, there is no single index of welfare status that one can use. UNICEF recommends the "Under 5 Mortality Rate (U5MR) as the best available single indicator of overall social development since most of the factors that define it comprise the essential needs of all human beings" (Florentino and Pedro, 1992). The U5MR reflects not only the nutritional and health status of children but also such determinants as nutritional and health status of children but also such factors as nutritional and health knowledge and practices of mothers, level of immunization, available maternal and child health



services, income and food available to the family, the availability of clean water, the state of environmental sanitation. Nevertheless, its broad coverage also highlights the need to supplement it with other indicators to be able to interpret its meaning. One needs to consider several measures or indicators to gauge the conditions of a household or individual. The use of several indicators is needed to capture the multi-dimensional character of poverty.

A related issue is how sensitive these indicators are to changes in macro policies. Since we would like to be able to modify current policies that inflict great costs on the vulnerable groups, we would like to know immediately its impacts on these groups. Therefore, indicators that are sensitive to policy changes are preferred even if they measure only one facet of human welfare.

Having identified a suitable set of indicators, there are problems ranging from lack of data or inconsistency in the definitions or estimation methodologies. Srinivasan (1992) points out the difference in coverage, the biases, and measurement errors in national accounts and survey data related to income distribution.

There is also the issue regarding the merits of "self-rating" versus "objective rating". In the former, the individual rates himself and this rating is used to distinguish the status of the individual. The Social Weather Station for instance, uses this approach in its regular surveys to distinguish between the "poor" and the "non-poor". The objective rating, on the other hand, distinguishes the status of the individual based on some criterion, or poverty line. Mangahas (1992) points out that the latter is also subjective like the former. The main difference is whose norm is being used in the classification. In the latter, some person or institution exercises its subjectivity by choosing the criteria for classifying everyone while in the former, the people themselves exercise the subjectivity to classify themselves.

For the monitoring system to be institutionalized at the barangay level, it should meet the data requirements of the barangay for making its development plan. It should also facilitate the identification of problem and possible solutions to the problems faced by the community.

Moreover, the data collected should be those that are quite easy to collect. Thus, it is envisioned that the monitoring system will revolve around the 19 minimum basic needs (MBN) indicators and supplemented by other data relevant to that particular community. The MBN indicators were drawn up by an inter-agency group for the use of Presidential Commission to Fight Poverty in identifying the "poor" groups.

***Who will be the community-based monitors?*** One of the basic issues to be addressed in the design of the MIMAP monitoring system is the choice of monitor to be utilized. The monitor is expected to do the following: (1) collect primary data; (2) process the

data; (3) collect secondary data; (4) consolidate the data available at the municipal/barangay level and; (5) maintain the databank at his level. This should be examined both at the barangay and municipal/city levels.

At the barangay level, there are also many potential monitors. Gironella, in an effort to develop a community-level statistical system that is responsive to the needs of the community, assessed the effectiveness of different barangay-level monitors. She identifies five groups of potential "Tagapangalap ng Inpormasyong Lokal" (TIL) for the barangay: (a) the councilmen; (b) barangay teachers; (c) educated youth; (d) adult volunteers; and (e) Barangay Nutrition Scholar.

The results of Gironella's study indicate that barangay teachers, the BNS, adult volunteers and the educated youth can be tapped to provide the necessary manpower for the generation of grassroots statistics. The performance of barangay teachers was consistently better than the other enumerators. The educated youth and the adult volunteers, however, require special qualification. The educated youth must be at least an elementary school graduate while the adult volunteer must be able to cope, physically and mentally, with the demands of the work.

Based on the findings of Gironella and the experiences of existing monitoring systems, we have identified the following monitors at the barangay level:

- (a) Barangay Nutrition Scholar (BNS)
- (b) Barangay council member

The Barangay Nutrition Scholar Project, started in 1977, aims to provide each barangay with a trained community worker called Barangay Nutrition Scholar, to deliver or facilitate the delivery of basic nutrition and health services. Based on a review of the program in 1984, there were 12,807 BNS trained with deployment coverage of almost 9,000 barangays. The Project was institutionalized through the issuance of Presidential Decree No. 1569 which provides for a BNS in every barangay. The inclusion of the BNSP in the National Priority Plan and the extension of civil service eligibility to deserving BNS who have served satisfactorily for at least two consecutive years further strengthened the BNS system. Presently, there are about 14,500 barangays out of the 45,000 barangays in the country who have BNS. The Project targets an additional 1,000 BNS every year.

According to this 1984 review, "the Project has demonstrated the viability of a community-based worker able to closely monitor the nutritional status of children and to bring program services closer to program targets through direct service delivery and referrals." The viability of the BNS as a community-based monitor is further supported by the experience of BIDANI.

Using the BNS as the local monitor offers many advantages: (a) there is an existing structure that provides for a BNS in every barangay; (b) the salaries are provided by the local government so there is minimal cost involved; and (c) among the MBN indicators the nutrition indicators are the only indicators that require some level of expertise, which the BNS has.

Since there is a barangay council in every barangay, the barangay council member is a likely monitor. As Gironella (1993) explained "the councilmen were among those identified (as potential *Tagapangalap ng Inpormasyong Lokal*) because they have direct contact with their constituents and therefore were perceived to be in the best position to collect data from the villagers without antagonizing them". Moreover, the barangay council members are directly benefitted because they can use the data as inputs in the preparation of the annual development plan for the barangay.

The barangay teachers, on the other hand, generally have better educational background and therefore are better data enumerators. It will be outside their regular responsibilities to be the barangay monitor. Moreover, not all barangays have barangay teachers. They also have no direct need for the data collected. Nevertheless, they could be tapped to collect some of the data.

At the municipal/city level, the following have been identified as potential MIMAP monitors:

- (a) the Municipal (City) Planning and Development Coordinator;
- (b) the Local Information Officer;
- (c) the Local Government Operations Officer; and
- (d) NSO personnel.

The Municipal (City) Planning and Development Coordinator is the most likely choice as MIMAP monitor. In fact, the MPDC (CPDC) has been used in the BIDANI system and is being proposed to be used in such monitoring systems as CBCMS, SWCDIS, and the CBIS and LIS for the evaluation of PPAC. An evaluation of these monitoring systems show that he is quite capable of performing this task. More importantly, he exists in all municipalities and his duties include the monitoring and evaluation of the implementation of the different development programs, projects, and activities in the local government unit concerned in accordance with the approved development plan. Attached as Annex G is the list of responsibilities of the Local Planning and Development Coordinator. However, the system still has to be improved. The most important component of the new system would be training the MPDC (CPDC) in the planning process. He has to be made aware of the uses of such a database in planning new programs and projects as well as evaluating impact of these

programs and projects. He also has to be trained on how to process the data sent to him from the barangays in such a way that he will be able to generate the needed information.

For bigger municipalities and cities, it is also possible to appoint a local information officer who will also serve as the MIMAP monitor. Among the responsibilities of the information officer is to "formulate measures for the consideration of the *sanggunian* and provide technical assistance and support to the governor or mayor, as the case may be, in providing the information and research data required for the delivery of basic services and provision of adequate facilities so that the public becomes aware of said services and may fully avail of the same." (See Annex H for the complete list of responsibilities).

Section 18 of the Local Government Code of 1991 provides that "local government units shall have the power and authority to establish an organization that shall be responsible for the efficient and effective implementation of their development plans, program objectives and priorities". This implies that the LGU can establish a small unit that can respond to its need for a local database that will provide inputs in its preparation of development plans. A potential MIMAP monitor therefore is the Local Government Operations Officer (LGOO), who is a field personnel of DILG. It would relatively be easy to institutionalize this because all that is required would be for the Secretary of DILG to amend the duties and responsibilities of the LGOO. Aside from establishing and maintaining the database on all barangay officials, his duties may be expanded to include the database on the MBN indicators. (See Annex I for the list of responsibilities).

Another option in the choice of the monitor is a personnel from NSO. However, the NSO does not have field offices in all municipalities. Instead, the NSO has district offices which may likewise be tapped for MIMAP monitoring as in the PRRM Project on the development of a district-based statistical and information system. The advantage of using the NSO personnel is that minimal training in data collection and processing will be required. On the other hand, some other institution or office will have to do the data analysis.

*Who has access to the data?* Gironella et al (1993) noted that "since the grassroots live practically as "one big family", the information that will be collected must be those that can be shared with everyone: that is, confidentiality of responses while a must in statistical systems may be difficult in an environment of mutual sharing."

Aside from income and expenditure data, the rest of the MBN indicators are not the type of information the individuals would be unwilling to share with others. While it is true that one may be less willing to share one's income and expenditures with someone from the same community, there is also the advantage that the monitor,

being from the same village, can "validate" the responses of the individuals. It becomes important then, that the monitor is someone who is respected in the community. The general public should have access only to the processed data while the program implementors and other relevant personnel are given the household/individual data to determine the target population for their programs. For instance, information on who the malnourished children are in the community should be made available to health workers.

*How should the system be implemented?* The proposed MIMAP monitoring system will be pilot tested in selected areas to be determined by the sampling design. The feasibility of tapping the identified monitors at the barangay and municipal levels to collect the MBN indicators will be pretested.

If there is an existing (or planned) monitoring system in the barangay, the strategy is to collaborate with the government agency or NGO who initiated the information system. If the proponent is willing, the existing monitoring system can either be adapted to the MIMAP system. This implies that the MBN indicators will be incorporated in the existing indicator system. This will not be too difficult considering that the various monitoring systems already include some of the MBN indicators. Alternatively, the MIMAP monitoring system will be installed to generate data not sufficiently covered by the existing monitoring system. MIMAP monitors will then rely on the government agency or NGO for the data on the other indicators.

Based on the assessment of existing and proposed community-based monitoring systems and the related studies, we are proposing a community-based monitoring system with the following features:

### **Proposed MIMAP Community-Based Monitoring System**

*Objective.* The MIMAP Monitoring System seeks to provide policymakers with regular and frequent information on the possible impacts of macroeconomic adjustment policies on the households and individuals, particularly those belonging to the vulnerable groups. This will be achieved by developing and institutionalizing a monitoring system consisting of a set of macro and micro level indicators.

*Coverage.* Poor households and disadvantaged groups will be the focus of the MIMAP Monitoring System. The Strategy Paper of the Presidential Commission to Fight Poverty identifies the following as some of the vulnerable groups: (1) lowland landless agricultural workers; (2) lowland small farm owners and cultivators; (3) upland farmers; (4) artisanal fisherfolk and; (5) urban poor. The proposed monitoring system will be installed in sentinel or index areas. A sampling design is being developed that will enable us to select barangays where the poor abounds. details of the design are in the paper of Maligalig (forthcoming).

**Indicators.** The indicators have been chosen based on the multi-dimensional character of poverty and have largely been confined to output and impact indicators. The set of indicators presented in Table 1 closely resemble the Minimum Basic Needs indicators of the Presidential Commission to Fight Poverty. The 18 indicators correspond to the minimum basic needs covering: (a) health; (b) nutrition; (c) water and sanitation; (d) income; (e) shelter; (f) peace and order; (g) basic education; and (h) political participation.

This core set of indicators may be supplemented by other indicators which are relevant to that particular community.

To be able to explain the observed trends in welfare status, these indicators have to be supplemented by barangay, municipality and provincial profiles and secondary data. The profiles would provide data on resources/facilities in the area available to the households. For example, the presence or absence of barangay health stations, while not an indicator of the welfare status of the household, would be an important variable in trying to explain the health status of the households in the area.

**Monitors.** The monitor is expected to supervise the collection of primary data, collect primary data, consolidate the data available at the provincial/municipal/barangay level, and maintain the databank at his level.

At the barangay level, the proposed community-based monitors are the barangay health workers (BHW) and the barangay nutrition scholars (BNS), barangay council members, and some community volunteers. A barangay council member, preferably the barangay chairman or the secretary, will be the coordinator.

At the municipality level, the MIMAP monitor will be the Municipal (City) Planning and Development Coordinator.

The Provincial Planning and Development Coordinator (PPDC) will consolidate the reports of the MPDCs and CPDCs in his province and forward the same to the National Statistics Office.

**Frequency of Collection.** Primary data collection is undertaken every quarter by the barangay monitors. Data that do not vary quickly over time may be collected less frequently, e.g., annually. Secondary data, if available, are used to supplement the primary data.

**Processing of Data.** Preliminary processing of the data is done by the barangay monitor to meet the information needs of the barangay in its preparation of its development plan. The original household data is kept at the barangay hall for the use of the program implementors. This serves as the databank at the barangay level.

## **Table 1**

### **MIMAP Indicators**

#### **HEALTH**

1. Infant Mortality Rate
2. Child Mortality Rate

#### **NUTRITION**

3. Prevalence of moderate and severe underweight
4. Prevalence of acute and chronic malnutrition
5. Prevalence of micronutrient deficiencies  
(anemia, endemic goiter, xerophthalmia)
6. Proportion of households with income greater than the food threshold

#### **WATER and SANITATION**

7. Proportion of households with sanitary toilet facilities
8. Proportion of households with access to safe water

#### **INCOME**

9. Proportion of households with income greater than the poverty threshold
10. Employment/Underemployment

#### **SHELTER**

11. Proportion of households in makeshift housing

#### **PEACE and ORDER**

12. Crime Incidence
13. Incidence of armed encounters

#### **BASIC EDUCATION and LITERACY**

14. Elementary enrollment
15. Completion Rate
16. Basic and functional literacy

#### **PARTICIPATION**

17. Proportion of households involved in at least one community organization
18. Proportion of households who participated in formal electoral processes

A copy of the household data as well as the initial tables prepared by the barangay monitor is sent to the city/municipal coordinator. The latter processes further the barangay data (n-way classification tables) and consolidates the data from the different barangays. He also supplements this with data from other government agencies and institutions. This will serve as the databank at the municipal level. The additional tables generated from the barangay data and other sources of information will be fed back to the barangay.

The information generated by the city/municipal monitor are submitted to the provincial monitor. The latter consolidates the data from the different municipalities and produces summary tables. These are then inputted into the provincial MIMAP databank.

The provincial monitor submits the provincial data to the national monitor, preferably the National Statistics Office, which does the consolidation. These are then made available to the macroeconomic planners to serve as inputs in their design of adjustment policies and other measures. (See Figure 6 for the flow of information of the MIMAP Monitoring System).

***Strategy for Implementation.*** The proposed MIMAP monitoring system will be pilot tested in selected areas to be determined by the sampling design. The viability of a monitoring system at the barangay level will be tested. In particular, the feasibility of tapping the identified monitors at the barangay and municipal levels to collect the MBN indicators will be tested.

If the collection, processing, analysis, and utilization of data at the barangay and municipal level can be handled adequately by the local government units, then it will be recommended to be made a regular function of the local government units.

If there is an existing monitoring system in the barangay, the strategy is to collaborate with the government agency or NGO who initiated the information system.

As these different monitoring systems become institutionalized, they could be linked together to form a wider base of information. This could be the key to the establishment of a nationwide statistical system at the grassroots level.

***Dissemination of Information.*** The information collected will be made available to the planning bodies, program implementors, and other interested organizations. The intention is for this to be a crucial input in the policy-making and planning process.



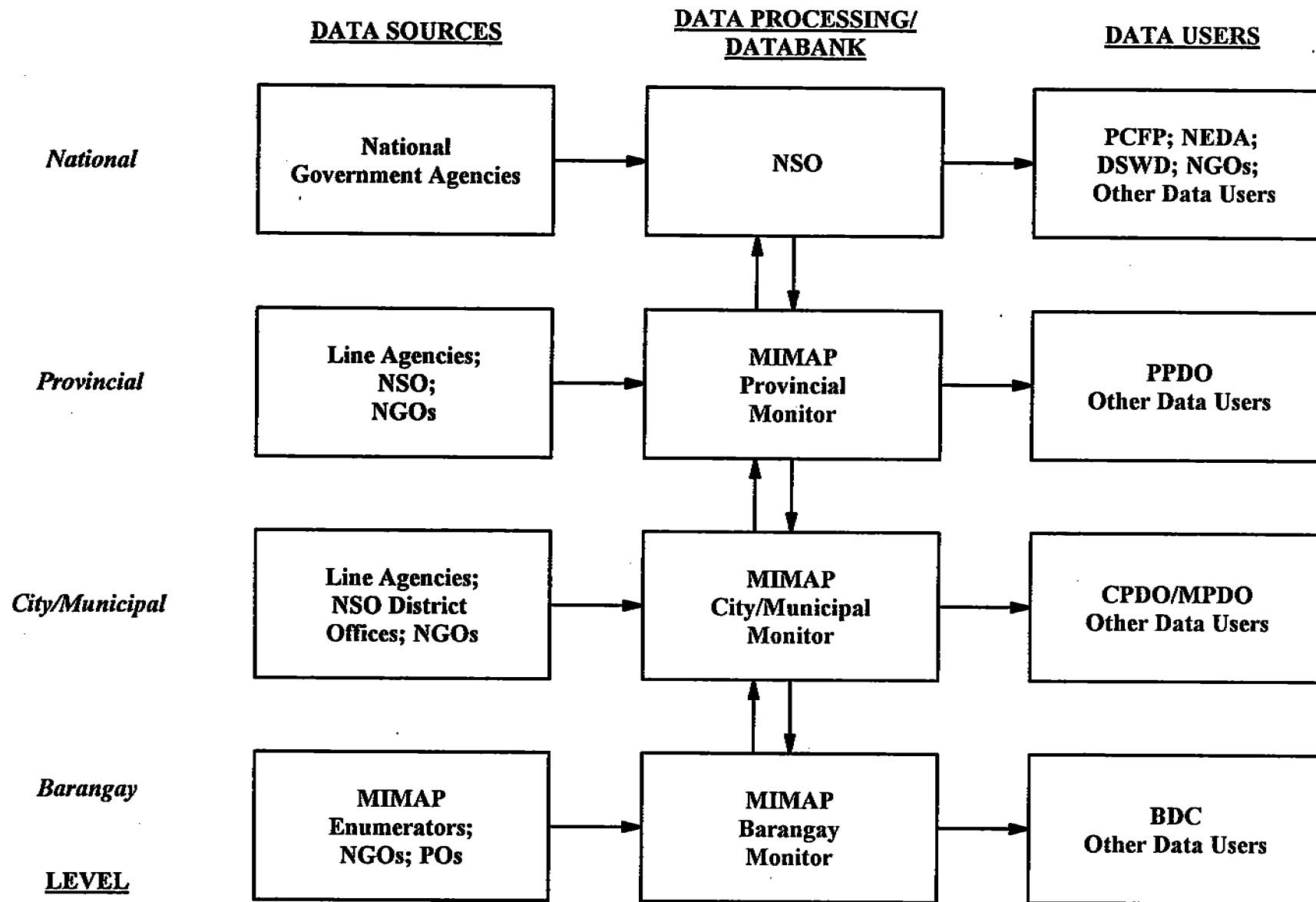

**Figure 6**  
**MIMAP MONITORING SYSTEM**  
**FLOW OF INFORMATION**

## 5. SUMMARY AND CONCLUSION

The review shows that there is a great demand for community-based monitoring systems. The different government agencies and non-governmental organizations are responding by installing their own monitoring systems.

The assessment of existing and proposed community-based monitoring systems indicate that the main features of these monitoring systems are very similar. The findings of the review include:

1. There are many existing community-based monitoring systems but they are mostly limited to small geographical areas. Table 2 shows the geographical coverage of the various monitoring systems. There are a few provinces which are included in all or most of the existing and proposed monitoring systems beyond the pilot-testing phase. Leyte is covered in all, while Bukidnon is covered in all except CBIS, Iloilo in all except SWCDIS and Davao in all except BIDANI. However, when we go down to the barangay level, we expect less convergence.
2. Data being collected are quite similar, with health and nutrition data present in many systems. Almost all of them have a number of the MBN indicators as part of their indicator system. (Refer to Table 3 for the comparison among various monitoring systems).
3. The monitors being tapped cover the same small range of LGU personnel, in line with the thrust towards decentralization and greater role for POs as shown in Table 4. Barangay health workers, barangay nutrition scholars and community volunteers are used as local monitors in many systems.
4. There is no attempt to consolidate the data from the different areas, even within the same project. Consequently, the use of the data has been very limited. Data collected are usually used by project proponents only as feedback and for project planning.
5. Time series data on socio-economic variables are not available, even for those barangays with long-running monitoring systems. Generally, the collection of data is coterminous with the lifetime of a specific program or project. Moreover, there is no system for storing the data for future retrieval. Thus, existing databases of NGOs cannot be used to test MIMAP hypotheses.

**Table 2**  
**GEOGRAPHICAL COVERAGE OF VARIOUS MONITORING SYSTEMS**

<b>MONITORING SYSTEM</b>	<b>CURRENT COVERAGE</b>	<b>FUTURE COVERAGE</b>	<b>LIST OF PROVINCES COVERED</b>
<b>BIDANI</b>	571 villages in 64 municipalities in 15 provinces (1993)	683 villages in 75 municipalities in 15 provinces (next 5 years)	Isabela, Cagayan, Quirino, Nueva Vizcaya, Nueva Ecija, Laguna, Balangas, Albay, Sorsogon, Leyte, Bukidnon, Antique, Iloilo, Basilan, Sulu
<b>CBCMS</b>	Pilot tested in 4 provinces: Ifugao, Negros Occidental, Maguindanao, Tawi-tawi (two municipalities from each province, and two barangays from each municipality, for a total of 16 barangays)		
<b>IRAP</b>	Pilot tested in seven provinces covering Regions 6,8,10 and 11 (Initial coverage under USAID funding: Camiguin, Romblon, Agusan del Norte, Capiz)	18 provinces by October 1994	Davao Oriental, Aklan, Bukidnon, Antique, Guimaras, Iloilo, Southern Leyte, Biliran, Surigao del Norte, Agusan del Sur, Misamis Occidental, Misamis Oriental, Davao del Sur, South Cotabato, Saranggani
<b>SWCDIS</b>		poverty mapping to be conducted in the 27 poorest provinces identified by PCFP	Sulu, Maguindanao, Masbate, Cotabato Ifugao, Zamboanga del Sur, Basilan, Zamboanga del Norte, Lanao del Sur, Surigao del Sur, Agusan del Sur, Tawi-tawi Kalinga-Apayao, South Cotabato, Lanao del Norte, Sultan Kudarat, Bukidnon, Negros Oriental, Western Samar, Capiz, Davao Oriental, Negros Occidental, Northern Samar, Leyte, Biliran, Misamis Occidental, Nueva Ecija
<b>CBIS AND LIS FOR PPAC</b>		15 regions, 45 provinces, 14 cities and 13 urban municipalities by end of 1998	Priority areas are the programme areas of convergence: Metro Manila, Angeles City, Olongapo City, Camarines Sur, Masbate, Sorsogon, Bacolod City, Iloilo City, Metro Cebu, Eastern Samar, Leyte, Northern Samar Western Samar, Cagayan de Oro City, General Santos City, Metro Davao
<b>DISTRICT-BASED STAT. SYSTEM (PRRM)</b>	Pilot-tested in three barangays in each of the following provinces with PRRM branches: Nueva Ecija, Negros Occidental, and North Cotabato		

**Table 3**  
**Indicators Generated by Various Monitoring Systems, By Area of Concern**

AREA OF CONCERN	MIMAP	BIDANI	CBOMS	IRAP	SWCDIS	PPAC Goals/Requirements
<i>Health</i>	Infant mortality rate Child mortality rate	Number of individuals with morbidity cases and cause of death	Total number of infant deaths	Accessibility indicator on health	Mortality rate	Reduction of infant deaths/diseases
<i>Nutrition</i>	Prevalence of moderate and severe underweight  Prevalence of acute and chronic malnutrition  Prevalence of micronutrient deficiencies  Income above the food threshold	Number of children weighed by age  Number of school age children with weight for age by nutritional status	Percentage of underweight preschoolers to total children 0-6 yrs. old		Incidence of severely and moderately underweight pre-school children among poverty threshold families	Increase in weight  Reduction of malnutrition: moderate and severe  Reduction of Vit. A deficiency, anemia and other micronutrient deficiencies
<i>Water &amp; Sanitation</i>	Proportion of households with access to sanitary toilet facilities  Proportion of households with access to safe water supply	Number of households with sanitary toilets, sanitary garbage disposal and safe drinking water supply	Percentage of households with access to sanitary toilet facilities  Proportion of households with access to safe water supply	Accessibility Indicator on water supply	Percentage of families with sanitary toilet facilities  Percentage of families with potable/safe water supply	Access to sanitary latrines by households  Access to sufficient potable water
<i>Income Security</i>	Income above the total poverty threshold Amount of household savings Employment or unemployment	Family income	Annual family income		Poverty incidence Food incidence  Employment rate	Improvement in income
<i>Shelter</i>	Proportion of households in makeshift housing				Percent distribution of families by housing materials	Materials used/type of dwelling
<i>Peace and Order</i>	Crime incidence Incidence of armed encounters				Crime rate	Reduction of incidence of harm on children
<i>Basic Education and Literacy</i>	Elementary enrollment  Completion rate  Basic and functional literacy			Accessibility indicator on education	Participation rate  Cohort survival rate  Illiteracy rate	Increased elementary participation rate  Increased number of children completing at least Gr. 6  Increase in the number of literate women and men
<i>Participation</i>	Membership in at least one area-based community organization  Participation in formal electoral exercises				Percentage of family members involved in community group	Increase in the number of participation in community activities of men, women and adolescents

**Table 4**  
**MONITORS UTILIZED BY VARIOUS MONITORING SYSTEMS**

<b>MONITORING SYSTEM</b>	<b>BARANGAY LEVEL</b>	<b>MUNICIPAL LEVEL</b>	<b>PROVINCIAL LEVEL</b>	<b>NATIONAL LEVEL</b>
<b>BIDANI</b>	<b>BNS</b>	<b>C/MPDC or C/MNAO</b>		
<b>CBCMS</b>	<b>Sitio/Barangay Volunteer Monitors</b>	<b>C/MPDC</b>	<b>PPDC</b>	
<b>IRAP</b>	<b>Key informants such as teachers, elders and baragay council members</b>	<b>MPDO</b>	<b>PPDO</b>	<b>DILG</b>
<b>SWCDIS</b>		<b>MPDO</b>	<b>PPDO</b>	<b>DSWD-PMS</b>
<b>CBIS AND LIS FOR PPAC</b>	<b>POs</b>	<b>Municipal Information Officer or MPDC</b>	<b>Provincial Information Officer or PPDC</b>	
<b>DISTRICT-BASED STAT. SYSTEM (PRRM)</b>	<b>BSUs* will be tapped as enumerators</b>	<b>NSO</b>	<b>NSO</b>	<b>NSO</b>

\*Basic Sectoral Units

The proposed MIMAP community-based monitoring system will tap the capabilities of local government units to collect, process, analyze and use household and community data. The proposed system will be pilot tested in selected areas to be determined by the sampling design. If found feasible, the system will be recommended to be made a regular part of decision-making and planning function of the local government units.

If there is an existing monitoring system in the barangay, the strategy is to collaborate with the government agency or NGO who initiated the information system.

As these different monitoring systems become institutionalized, they could be linked together to form a wider base of information. This could be the key to the establishment of a nationwide statistical system at the grassroots level.

## REFERENCES

- Castro, Nestor C. "The CBCMS: Towards a Barangay-Based Statistical System" (Paper presented at the Symposium on the Development of Subnational Statistical Systems: the RSSDP and the CMP Experiences). National Statistical Coordination Board, 1991.
- Center for Policy and Administrative Development, College of Public Administration, U.P. "A Handbook for Local Government Units of the Integrated Approach to Local Development Management for the Philippine Plan of Action for Children". October 1993.
- Community Health through Integrated Local Development (CHILD) Project Region XI Steering and Technical Committee. "A Final Report on the CHILD Project in Region XI". (Submitted to USAID), February 1991.
- Congress of the Republic of the Philippines of 1987-1992. The Local Government Code of 1991 (Republic Act No. 7160).
- Cornia, Giovanni, R. Jolly and F. Stewart, eds. Adjustment with a Human Face. Oxford: Clarendon Press, 1987.
- Davao Medical School Foundation-Institute of Primary Health Care (DMSF-IPHC). "A Manual: DMSF/IPHC-LDAP Experience" (A report of the Partnership Mechanism in the Management of Basic Health Care Programs and Services Project submitted to the Local Development Assistance Program, Philippine Business for Social Progress), 1993.
- Department of Interior and Local Government and the International Labour Organisation. "Planning for People's Needs" (Integrated Rural Accessibility Planning (IRAP) Project Brochure).
- \_\_\_\_\_. "IRAP Issue Paper No. 1: Rural Accessibility Planning and the Use of Accessibility Indicators", July 1993.
- Department of Social Welfare and Community Development. Social Welfare and Community Development Information System (SWCDIS) Project Document.
- Escueta, Eva F. "Community-Based Statistics and Information System (CBSIS) on Agrarian Reform and Rural Development: Appraisal Report". Institute of Agrarian Studies, U.P. Los Banos, College, Laguna, 1988.

- Eusebio, J.S., M.A.G. Tuazon, Z.B. Penaflor and Associates. "Barangay Integrated Development Approach for Nutrition Improvement of the Rural Poor: A Nutrition-in-Development Network Program". Institute of Human Nutrition and Food, College of Human Ecology, U.P. Los Banos, 1991.
- Eusebio, J.S., R.C. Dacanay, Ma. C.P. Ramos and L.L. Lantican. "Field Guide on Comprehensive Planning, Monitoring and Evaluation of Nutrition-Oriented Rural Development Program at Local Levels", 1991.
- Florentino, Rodolfo F. and Pedro, Ma. Regina A. "Monitoring the Micro Impact of Macroeconomic Adjustment Policies (MIMAP)" (Working Paper Series No. 92-19). Philippine Institute for Development Studies, September 1992.
- Gironella, Ann Inez N., Flores, Nydia A., and Garcia, Niela T. "Development of a Statistical System at the Grassroots Level" (Final report submitted to the Statistical Research and Training Center). U.P. Los Banos, College, Laguna, 1992.
- Lamberte, M., G. Llanto, M.L. Lapar and A. Orbeta, Jr. "Micro Impacts of Macroeconomic Adjustment Policies (MIMAP): A Framework Paper and Review of Literature" (Working Paper Series No. 91-02). Philippine Institute for Development Studies, February 1991.
- Lamberte, M., G. Llanto and A. Orbeta, Jr. "Micro Impacts of Macroeconomic Adjustment Policies (MIMAP): Phase II Integrative Report" (Working Paper Series No. 92-13). Philippine Institute for Development Studies, October 1992.
- Mangahas, Mahar. "Self-Rated Poverty in the Philippines, 1981-1992". (Unpublished) December 1992.
- Mindanao Training Resource Center and the Institute of Primary Health Care, Davao Medical School Foundation. Training Package on Community Organizing-Participatory Action Research. April 1992.
- National Economic and Development Authority and the UNICEF. "Programme of Cooperation for Child Survival, Protection and Development in the Philippines, 1994-1998: A Summary". July 1993.
- National Statistical Coordination Board. "Proceedings of the National Sharing on the CBCMS Experience" (held on April 15, 1993 at the Occupational Safety and Health Center).
- National Statistics Office. "A Study on Decentralization and the Philippine Statistical System, Phase II Midterm Report (October 1, 1992 - June 30, 1993)".



Philippine Partnership for the Development of Human Resources in Rural Areas and the International Development Research Centre. "CIPS in the Field" (The Final Report of the Project, Participatory Research in Community Education, 1987-89).

Philippine Rural Reconstruction Movement. "District-Based Statistical and Information System with Community Sentinels" (Project Document).

*Samahang Ugnayan ng Gawaing Pampamayanan sa Olongapo*. Briefing materials used in the presentation on CBM for the MIMAP PMO held on April 26, 1994 at the City Health Office of Olongapo City.

Srinivasan, T.N. "Income Distribution and the Macroeconomy: Some Conceptual and Measurement Issues". *Journal of Philippine Development* (1992):1-27.

## Tanauan Indicator System

PROJECT/ACTIVITY	CHOSEN VARIABLES IN THE HIPPOPOC TABLE	INDICATOR
<b>A. FOOD PRODUCTION</b>		
1. Promotion of food and feed crops	<p>Output - 21 bgy. campaigned on the use of HYV seeds</p> <p>Outcome - increased availability of crops</p>	<ul style="list-style-type: none"> <li>● Number of farmers per barangays campaigned on use of HYV seeds</li> <li>● Number of farmers using HYV seeds</li> <li>● Average yield of production per cropping season by type or quality of produced</li> </ul>
2. Animal breeding services	<p>Output - 35 heads/mo (large animals); 75 heads/ mo. (swine) distributed were given artificial insemination</p>	<ul style="list-style-type: none"> <li>● Number of farmers with cattle/stock given artificial insemination</li> </ul>
3. Distribution of emancipation patent for rice and corn land	<p>Output - 61 titles given to landless farmers</p>	<ul style="list-style-type: none"> <li>● Number of titles distributed to farmers by villages</li> </ul>
a. Voluntary offer to sell (VOS)	<p>- 125 title for VOS distributed to landless farmers</p>	<ul style="list-style-type: none"> <li>● Number of farms planted with rice and corn among beneficiaries for period of one year</li> <li>● Number and type of titles for VOS distributed to landless farmers in one year</li> </ul>
b. Government owned land (GOL)	<p>- 20 deed of sale for government owned lands distributed to landless farmers within a year</p>	<ul style="list-style-type: none"> <li>● Number of deed of sale for government-owned lands distributed to landless farmers within one year</li> </ul>
4. Land Acquisition Operation Land Transfer (OLT) for rice and corn	<p>Output - acquisition of farm planted with rice and corn from farmers owning 7 has. and above within one year through OLT</p>	<ul style="list-style-type: none"> <li>● Number of farms acquired from large farmers <math>\geq 7</math> ha within a year</li> </ul>
5. Voluntary offer to sell	<p>Output - 27 has. under fore closed property voluntarily offered to sell the land to DAR office within one year</p>	<ul style="list-style-type: none"> <li>● Number of land owners with foreclosed property voluntarily offered to sell their land to DAR office by area in ha within one year</li> </ul>
6. Leasehold contract	<p>Process - DAR technician conducts personal contact with the person</p>	<ul style="list-style-type: none"> <li>● Effective personal contact with the person</li> </ul>
7. School gardening	<p>Output - school children grades 4 and 5 encourage to raise vegetables crops per plot within school year in 48 bgy</p>	<ul style="list-style-type: none"> <li>● Number of children raising vegetable crops by villages within school year</li> <li>● Type of crops raised</li> </ul>

EVALUATION/Indicator

PROJECT/ACTIVITY	CHOSEN VARIABLES IN THE HIPPOPOC TABLE	INDICATOR
<b>B. EDUCATION AND TRAINING</b>		
1. Post-harvest handling practices	Process - DA technician gathers data on post-harvest practices  Output - 75% of farmers below poverty line	<ul style="list-style-type: none"> <li>● % of harvest losses/season</li> <li>● Post harvest practices (descriptive)</li> <li>● % of farmers below poverty line trained on post-harvest handling practices within a period of one year</li> </ul>
2. Training of contact leaders	Process - DA technicians train contact leaders	<ul style="list-style-type: none"> <li>● Conduct and content of training(descriptive)</li> <li>● Number of active contact leaders after the training</li> </ul>
3. Promotion of improved home management	Outcome - increased knowledge in home management	<ul style="list-style-type: none"> <li>● Practices in home management after 3 mo training (descriptive)</li> </ul>
4. Skills training	Output - 50 beneficiaries of CARP provided with training	<ul style="list-style-type: none"> <li>● Number of skills training in a year</li> <li>● Number of participants and beneficiaries of the project</li> <li>● Number of trained beneficiaries engaged in the identified enterprise</li> </ul>
5. Business management training	Output - 5 new entrepreneurs established	<ul style="list-style-type: none"> <li>● Number of entrepreneurs developed in a year</li> </ul>
6. Vocational skills development	Output - 93 families; 50 disabled .....	<ul style="list-style-type: none"> <li>● Number of beneficiaries trained by type of training provided</li> <li>● Number of beneficiaries practicing the skill</li> </ul>
7. Organization and reactivation of volunteers for environmental sanitation and use of herbal medicine	Input - manpower of DOH and DSWD	<ul style="list-style-type: none"> <li>● Number of technicians involved in the organization and re-activation of volunteer within 6 months</li> </ul>
	Output - 360 volunteers trained on proper environmental sanitation	<ul style="list-style-type: none"> <li>● Number of technicians involved in the organization and re-activation of volunteer trained on environmental sanitation and use of herbal medicines within 6 mo</li> <li>● Number of households reached out by each volunteer within 6 months</li> </ul>
	Outcome - household knowledge on herbal medicine  - improved sanitation of targeted households	<ul style="list-style-type: none"> <li>● Type and frequency of use of herbal medicines by households in a month</li> <li>● Number of households with sanitary toilets, sanitary garbage disposal and safe drinking water supply</li> </ul>
8. Organization of Mother's Class for training and seminars on nutrition, intra-household distribution of food, neighborhood feeding center, family planning/responsible parenthood	Output - 50 mothers with malnourished children organized within a period of 6 mo	<ul style="list-style-type: none"> <li>● Number of mothers with malnourished children organized within a period of 6 mo</li> <li>● Number of FP acceptors reached out in a year</li> <li>● Number of mothers encouraged to practice breastfeeding in 6 mo</li> <li>● Number of couples given pre-marriage counselling in one year</li> </ul>

**EVALUATION/Indicator**

PROJECT/ACTIVITY	CHOSEN VARIABLES IN THE HIPPOC TABLE	INDICATOR
9. Pre-marriage counselling	Outcome - reduced growth rate	<ul style="list-style-type: none"> <li>● Annual growth rate</li> <li>● Average size of family</li> <li>● Number of families utilizing methods of family planning and by type or by method used</li> </ul>
10. Training of PBAC and PMC	Process - DILG conducts training	<ul style="list-style-type: none"> <li>● Content of training</li> <li>● Frequency of training on PBAC and PMC</li> <li>● Process of training</li> </ul>
<b>C. LIVELIHOOD AND INCOME GENERATION</b>		
1. LEAD Project	Outcome - increased income of family	<ul style="list-style-type: none"> <li>● % of families with net income after project operation (every 6 mo)</li> </ul>
2. Dairy development	Process - Beneficiaries of Cooperative operationalize and collect produced milk	<ul style="list-style-type: none"> <li>● Process of milk collection (descriptive)</li> </ul>
3. Integrated farming	Output - 1-3 heads milking cows/cooperator distributed	<ul style="list-style-type: none"> <li>● Number of milking cows distributed to farmers in a year</li> </ul>
4. Self-employment assistance program	Output - 16 farmers interested...	<ul style="list-style-type: none"> <li>● Number of farmers engaged in integrated farming in one year</li> </ul>
4. Self-employment assistance program	Output - 65 disadvantaged families .....	<ul style="list-style-type: none"> <li>● Number of beneficiaries by type given SEAP and type of enterprise involved in the implementation</li> </ul>
<b>D. INSTITUTIONAL SUPPORT DEVELOPMENT</b>		
1. Organization of multi-purpose coop	Process - coop members operationalize the multi-purpose coops with DA personnel  Outcome - increase net returns per season	<ul style="list-style-type: none"> <li>● Number of organized multi-purpose coops and members</li> <li>● Management and operation of multi-purpose cooperatives (descriptive)</li> <li>● Average cost of production per crop per season</li> <li>● Average yield of production per cropping season</li> </ul>
2. Filling up 8 BIDW s in 8 villages	Process - Members of Management Staff set up criteria for selection of BNS-DW  Output - BNS-DWS employed	<ul style="list-style-type: none"> <li>● Number of BNS-DWs employed</li> <li>● Criteria used in the selection of BNS-DWs in 8 barangays</li> </ul>
3. Strengthening the interlacing of agency program/project/activity with local officials	Output - 10% of the development fund utilized for strengthening the development program	<ul style="list-style-type: none"> <li>● Amount and source of fund used for strengthening the development program</li> </ul>

EVALUATION/Indicator

PROJECT/ACTIVITY	CHOSEN VARIABLES IN THE HIPPOC TABLE	INDICATOR
<b>E. NUTRITION, HEALTH AND SANITATION</b>		
1. Filling up one anesthesiologist	Input - money for transportation of personnel	● Amount of money spent for transportation of personnel following up the request
	Outcome - increased utilization of government services	● % of people utilizing health services at the rural health center
2. Pre-natal and natal check-up	Output - 2,107 pregnant receiving monthly pre-natal and natal check up	● Number of pregnant mothers with pre-natal service by frequency of consultation per month
	Outcome - improved health condition of mother and child	● Number of individual with type and occurrence of illnesses
	- improved nutritional status of mother and child	● Number of individual with morbidity cases and cause of death
3. Immunization	Output - 1,807 0-1 year old children have been immunized for a period of one year	● Number of 0-1 year old children who had been immunized in one year period
	Outcome - reduced occurrence of tetanus among pregnant mothers	● Frequency of occurrence of tetanus among pregnant mothers
4. Nutrition surveillance (OPT)	Output - all children 0-83 mo old had been weighed	● Number of children weighed by age, monthly/quarterly
5. Goiter control	Output - 172 patients with goiter had been treated within a period of one year	● Number of patients with goiter treated in one year period
6. National tuberculosis program	Output - 6,880 patients had been identified as symptomatic 1672 identified with TB cases and treated by DOH personnel	● Number of patient identified as symptomatic
		● Number of patients identified with TB cases
		● Number of patients with TB who were treated by DOH personnel
7. Supplementary feeding for school children	Outcome - better nutritional status of school children	● Number of school age children with weight for age by nutritional status
<b>F. INFRASTRUCTURE DEVELOPMENT</b>		
1. Construction of additional health station for 2 bgy	Input - construction materials	● Type and quality of materials inputted in the construction,
	Process - SB endorses the resolution	● Source of fund and when implemented
	Output - barangay centers constructed	● Endorsement of SB (descriptive)
		● Number of Barangay Centers constructed in 1 year
2. Repair and maintenance of farm-to-market road	Output - farm-to-market road approximately 83 km repaired and maintained throughout the year	● Number of farm-to-market roads repaired and maintained in 1 year
3. Repair and rehabilitation of school building	Output - 50% of barangay school building repaired	● Number of school buildings repaired in a year

ANNEX B

**DUTIES AND RESPONSIBILITIES OF PERSONS/GROUPS INVOLVED IN  
THE INSTALLATION AND MAINTENANCE OF THE BIDANI DATABANK**

<b>Persons/Groups Involved</b>	<b>Duties and Responsibilities</b>
1. C/MPDC and/or C/MNAO	Consolidates data or information submitted by different line agencies or institutions  Maintains data bank and makes accessible to the people  Motivates line agencies to submit data or information on time
2. Supervisory Staff (Field Technicians)	Appraises quality of data collected by the BNS-DWs and other local leaders  Submits summarized data to the Management Staff  Assists the BNS-DWs in data collection
3. Management Staff (Heads of line agencies)	Consolidates data submitted by the Supervisory Staff  Submits consolidated data or reports to the C/MPDC or C/MNAO
4. Other Institutions or NGOs	Students or researchers gathering data in covered villages provide copy of their data or report to the C/MPDC and/or C/MNAO

## ANNEX C

### **The Barangay Health Data Board**

The barangay health data board is a board showing the map of the barangay with all the important landmarks in it, like roads and rivers, churches and school buildings. The central focus of the map is the houses of barangay members. These houses are not painted but are pasted/stified on the board map, as these are made of cut cartolina, easily detachable by the year-end when the periodically needed data are already recorded or reflected.

Written on the upper portion (roof) of the cut houses are the household/family numbers and the names of the household heads. The roof portion may also contain symbolic drawings signifying certain data on morbidity, such as the endemic diseases afflicting the household members. Using crayons, the rooftop of the cut-house may also be colored differently to indicate the social or political status of the family head or his wife, i.e., green for barangay health workers; yellow for purok leaders; red for barangay captain/officials; blue for transient residents/variety store; violet for municipal official.

The main portion of the cut-house contains intersecting horizontal and vertical lines producing the appearance of boxes or horizontal and vertical bars. The vertical bars represent the key health variables or indicators, such as nutrition (N), immunization (I), family planning (FP), pregnancy (P), water source (WS), toilet (T), drainage (D), and garbage disposal (GD). The horizontal bars indicate the timetable during which the health data will be entered in the corresponding boxes. As a general rule, the health data are updated quarterly (Q). The baseline data (BL), however, are retained even when the cut-house will already be replaced by a new one for next year's use.

Specific health data are encoded in their respective boxes in the cut-house through the use of specific colors. Different colors bear different meanings; the same color, when put in on several vertical bars, may refer to different data. Generally, however, the red color indicates "danger"; yellow means "relatively safe"; green signifies "good"; and blue denotes "not applicable".

## LIST OF INDICATORS BY COMPONENT, BY FACTOR AND BY LEVEL : SWCDIS

Components	Status and Conditions			Programs and Services			Resources			Environment						
Factors	INDICATOR	N	R	P/M	INDICATOR	N	R	P/M	INDICATOR	N	R	P/M	INDICATOR	N	R	P/M
Income/Employment	* Poverty Incidence	/	/	/	* Percentage of poverty threshold family members who have been provided with livelihood assistance by type of clientele by agency category, by sex, urban/rural				* Ratio of livelihood workers to total number of poverty threshold family members.			/	/			
	* Food Incidence	/	/													
	* Average family income among poverty threshold families	/	/						* Ratio of government expenditure for livelihood services by clientele and source of funding urban/rural			/	/			
	* Employment rate of family heads among poverty threshold families	/	/		* Percentage of food threshold family members provided with livelihood assistance by type of assistance clientele category by Age group, Urban, Rural, by sex			/	/							
					* Percentage of youth (7-21 yrd old) in specially difficult circumstances served who become economically productive/employed/self-employed.			/	/							
					* Percentage of women in especially difficult circumstances served, who became economically productive/employed/self-employed			/	/							



Components	Status and Conditions				Programs and Services				Resources				Environment			
	INDICATOR	N	R	P/M	INDICATOR	N	R	P/M	INDICATOR	N	R	P/M	INDICATOR	N	R	P/M
Factors				C				C				C				C
					* Percentage of disabled persons who became economically productive/employed/self-employed											
					* Percentage of elderly (60 yrs old and above) population served who became economically productive/employed/self-employed											
					* Percentage of disadvantaged population in cultural communities served, who became economically productive/employed/self-employed											
Nutrition	* Incidence of severely and moderately underweight pre-school children among poverty threshold families	/	/	/	/	* Percentage of moderately and severely underweight children of poverty threshold families provided supplemental feeding					* Ratio of centralized neighborhood feeding centers organized to total pre-schoolers of poverty threshold families					
	* Incidence of high risk family members (pregnant/lactating mothers)	/	/	/	/	* Percentage of pregnant and lactating mothers served by the type of programs					* Ratio of government and non-government expenditures for nutrition services					

Components	Status and Conditions			Programs and Services			Resources			Environment		
Factors	INDICATOR	N	R	P/M	INDICATOR	N	R	P/M	INDICATOR	N	R	P/M
				C				C				C
Health	* Life expectancy	/	/		* Percentage of poverty threshold family members by age group having access to health care services				* Ratio of government and non-government expenditures for health services by type by clientele category, urban/rural, sex			
	* Mortality Rate by Cause	/	/	/		/	/					
	* Morbidity Rate by Cause	/	/	/						/	/	
	* Incidence of disabilities among 0-6 yrs. old children by type, sex, area urban/rural				* Percentage of immunized pre-schoolers of poverty threshold families -		/	/	* Ratio of health workers to target population by category		/	/
Water and Sanitation					* Percentage of families with potable safe/water supply		/	/				
					* Percentage of families with sanitary toilet facilities		/	/				
Education	* Illiteracy rate	/	/		* Percentage of children among poverty threshold families in school and not in school		/	/	* Percentage of GO/NGO expenditure for public education		/	/
	* Participation rate											
	* Cohort survival rate				* Percentage of disadvantaged individuals trained on non-formal education activities by type of activity, by sex		/	/	* Ratio of day care workers to the number of pre-schoolers of poverty threshold families		/	/
	* Drop out rate	/	/						* Ratio accredited of day care centers to pre-schoolers of food threshold families		/	/
					* Percentage of poverty threshold family members trained by type by sex, by age, group, urban/rural		/	/				



Components Factors	Status and Conditions			Programs and Services			Resources			Environment							
	INDICATOR	N	R	P/M	INDICATOR	N	R	P/M	INDICATOR	N	R	P/M	INDICATOR	N	R	P/M	C
Community Life and Participation					* Percentage of disaster victims served.			/ /	* Ratio of government expenditures for relief operations				* Migration rate to urban centers	/ /			
					* Percentage of rebel returnees served			/ /	* Ratio of government expenditures for cooperatives				* Percentage of disaster prone barangays/areas to total number of barangays	/ / /			
					* Percentage of family members involved in community group by age group by type of organized group			/ /					* Percentage of affected barangays by type	/ / /			
Peace and Order													* Crime rate by type by urban/rural	/ / / /			

Note:

N - National

R - Regional

P/C - Provincial/City

M - Municipal

**AGENCIES/OFFICES INVOLVED IN  
SOCIAL WELFARE AND DEVELOPMENT**

**A. As Data Source/Producer**

National Statistics Office (NSO)  
Department of Labor and Employment (DOLE)  
Department of Health (DOH)  
Department of Education, Culture and Sports (DECS)  
Presidential Commission on the Urban Poor (PCUP)  
Food and Nutrition Research Institute (FNRI)  
Office of Northern Cultural Communities (ONCC)  
Office of Southern Cultural Communities (OSCC)  
Office of Muslim Affairs (OMA)  
Other Government Offices (GOs)  
Non-Governmental Organizations (NGOs)  
Local Government Offices  
    Provincial Planning and Development Office (PPDO)  
    City Planning and Development Office (CPDO)  
    Municipal Planning and Development Office (MPDO)  
    Barangay Development Council (BDC)

**B. As Data Users**

Office of the President (OP)  
National Government Agencies (NGAs)  
Non-Governmental Organizations (NGOs)  
Department of Interior and Local Government (DILG)  
Presidential Commission to Fight Poverty (PCFP)  
Congress  
Presidential Commission on Urban Poverty (PCUP)  
National Statistical Coordination Board (NSCB)  
National Economic and Development Authority (NEDA)

## MINIMUM BASIC NEEDS FOR PPAC

<i>MBNs</i>	<i>Primary Requirements/ Standards</i>	<i>Goals/Desired Outcomes</i>
<b>Survival</b>		
<b>Maternal health</b>	♦ Pregnant women given at least 2 doses of tetanus toxoid	♦ Reduction of maternal diseases/deaths
	♦ At least three pre-natal care consultations	
	♦ Delivery by trained personnel	♦ Reduction of deaths from tetanus neonatorum
	♦ Pregnant/lactating mother provided with ferrous sulfate and other required micro-nutrients (e.g., iodine in iodine endemic areas)	♦ Reduction of incidence of anemia and iodine deficiency
	♦ Birth interval of not less than 2 years	♦ Reduction of maternal diseases/deaths
<b>Child health</b>	♦ Full immunization of under-one year old	♦ Reduction of infant diseases/deaths
	♦ Early detection and management of pneumonia and other acute respiratory infection (ARI)	♦ Reduction of incidence and deaths from pneumonia and ARI
	♦ Early detection and management of diarrhea	♦ Reduction of incidence and deaths from diarrhea
<b>Adequate nutrition</b>	♦ Infants breastfed for at least four months	♦ Reduction of malnutrition--moderate and severe
	♦ Infant birth weight not less than 5.5 lbs.	♦ Reduction of infant diseases/deaths
	♦ Monthly growth monitoring of infants and children	♦ Increase in weight
	♦ Under-5 children provided with Vitamin A, iron and other micro-nutrients	♦ Reduction of vitamin A deficiency, anemia and other micro-nutrient deficiency

## MINIMUM BASIC NEEDS

<i>MBNs</i>	<i>Primary Requirements/ Standards</i>	<i>Goals/Desired Outcomes</i>
<b>Water and sanitation</b>	<ul style="list-style-type: none"> <li>♦ Access to sufficient potable water based on Dept. of Health standard by household</li> <li>♦ Access to sanitary latrines by household</li> <li>♦ Access to garbage and drainage system by household</li> </ul>	<ul style="list-style-type: none"> <li>♦ Reduction of diarrheal diseases</li> </ul>
<b>Protection</b>		
<b>Security and safety</b>	<ul style="list-style-type: none"> <li>♦ Facilities/measures to respond to children in difficult circumstances, i.e. armed conflict, disaster, street children, physical abuse</li> </ul>	<ul style="list-style-type: none"> <li>♦ Reduction of incidence of harm on children</li> </ul>
<b>Housing</b>	<ul style="list-style-type: none"> <li>♦ Ownership status</li> <li>♦ Materials used/type of dwelling</li> <li>♦ No. of persons sharing space</li> </ul>	
<b>Enabling Activities</b>		
<b>Education</b>	<ul style="list-style-type: none"> <li>♦ 3-6 children attending day care center</li> <li>♦ 7-12 children enrolled in primary education</li> <li>♦ Availment of nonformal functional literacy activities</li> </ul>	<ul style="list-style-type: none"> <li>♦ No. of children in 3-6 age group with center-based early childhood care and development</li> <li>♦ Increased elementary participation rate</li> <li>♦ Increased number of children completing at least Grade 6</li> <li>♦ Increase in the number of literate women and men</li> </ul>
<b>Livelihood/Income</b>	<ul style="list-style-type: none"> <li>♦ Full employment</li> <li>♦ Above poverty line</li> </ul>	<ul style="list-style-type: none"> <li>♦ Improvement in income</li> </ul>
<b>Participation</b>	<ul style="list-style-type: none"> <li>♦ Involvement in at least one people's organization</li> </ul>	<ul style="list-style-type: none"> <li>♦ Increase in number of participation in community activities of men, women and adolescents</li> </ul>

## ANNEX G

### **Duties and Responsibilities: Local Planning and Development Coordinator**

The appointment of a planning and development coordinator shall be mandatory for provincial, city, and municipal governments. The planning & development coordinator shall take charge of the planning and development office and shall:

- (a) Formulate integrated economic, social, physical, and other development plans and policies for consideration of the local development council;
- (b) Conduct continuing studies, researches, and training programs necessary to evolve plans and programs for implementation;
- (c) Integrate and coordinate all sectoral plans and studies undertaken by the different functional groups or agencies;
- (d) Monitor and evaluate the implementation of the different development programs, projects, and activities in the local government unit concerned in accordance with the approved development plan;
- (e) Prepare comprehensive plans and other development planning documents for the consideration of the local development council;
- (f) Analyze the income and expenditure patterns, and formulate and recommend fiscal plans and policies for consideration of the finance committee of the LGU concerned;
- (g) Promote people participation in development planning within the LGU concerned;
- (h) Exercise supervision and control over the secretariat of the local development council;
- (i) Exercise such other powers and perform such other functions and duties as may be prescribed by law or ordinance.



**Duties and Responsibilities:  
Local Information Officer**

The appointment of the information officer is optional for the provincial, city, and municipal governments. The term of the information officer is coterminous with that of his appointing authority. The information officer shall take charge of the office on public information and shall:

- (a) Formulate measures for the consideration of the sanggunian and provide technical assistance and support to the governor or mayor, as the case may be, in providing the information and research data required for the delivery of basic services and provision of adequate facilities so that the public becomes aware of said services and may fully avail of the same;
- (b) Develop plans and strategies and, upon approval thereof of the governor or mayor, as the case may be, implement the same, particularly those which have to do with public information and research data to support programs and projects which the governor or mayor is empowered to implement and which the sanggunian is empowered to provide for under the Code;
- (c) In addition to the foregoing duties and functions, the information officer shall:
  - (i) Provide relevant, adequate, and timely information to the LGU and its residents;
  - (ii) Furnish information and data on local government units to government agencies or offices as may be required by law or ordinance; and non-governmental organizations to be furnished to said agencies and organizations;
  - (iii) Maintain effective liaison with the various sectors of the community on matters and issues that affect the livelihood and the quality of life of the inhabitants and encourage support for programs of the local and national government;
- (d) Be in the frontline in providing information during and in the aftermath of man-made and natural disasters and calamities, with special attention to the victims thereof, to help minimize injuries and casualties during and after the emergency, and to accelerate relief and rehabilitation;

- (e) Recommend to the sanggunian and advise the governor or mayor, as the case may be, on all other matters relative to public information and research data as it relates to the total socioeconomic development of the local government unit; and
- (f) Exercise such other powers and perform such duties and functions as may be prescribed by law or ordinance.

**ANNEX I**

**Duties and Responsibilities:  
Municipal Government Operations Officer**

- (a) Plans, organizes, directs, implements and monitors the Department's programs, projects and activities in the municipalities.
- (b) Disseminates and monitors compliance with the implementation of laws, rules and regulations, policies and standards and other issuances affecting local government.
- (c) Strengthens the viability of Local Government Councils, POCs & ABCs.
- (d) Maintains linkages with the League of Municipal Mayors and other organizations.
- (e) Provides technical assistance and consultancy services in municipal government administration and development.
- (f) Disseminates information regarding the Department and its services in the municipalities.
- (g) Establishes and maintains data bank of municipal and barangay officials and of their assigned areas.
- (h) Supervises and coordinates the work of the LGOO II in the municipality.