

Wyllie, Mike

**Working Paper**

## Developments in the "LNG to Power" market and the growing importance of floating facilities

OIES Paper: NG, No. 172

**Provided in Cooperation with:**

The Oxford Institute for Energy Studies, Oxford

*Suggested Citation:* Wyllie, Mike (2021) : Developments in the "LNG to Power" market and the growing importance of floating facilities, OIES Paper: NG, No. 172, ISBN 978-1-78467-181-5, The Oxford Institute for Energy Studies, Oxford

This Version is available at:

<https://hdl.handle.net/10419/246578>

**Standard-Nutzungsbedingungen:**

Die Dokumente auf EconStor dürfen zu eigenen wissenschaftlichen Zwecken und zum Privatgebrauch gespeichert und kopiert werden.

Sie dürfen die Dokumente nicht für öffentliche oder kommerzielle Zwecke vervielfältigen, öffentlich ausstellen, öffentlich zugänglich machen, vertreiben oder anderweitig nutzen.

Sofern die Verfasser die Dokumente unter Open-Content-Lizenzen (insbesondere CC-Lizenzen) zur Verfügung gestellt haben sollten, gelten abweichend von diesen Nutzungsbedingungen die in der dort genannten Lizenz gewährten Nutzungsrechte.

**Terms of use:**

*Documents in EconStor may be saved and copied for your personal and scholarly purposes.*

*You are not to copy documents for public or commercial purposes, to exhibit the documents publicly, to make them publicly available on the internet, or to distribute or otherwise use the documents in public.*

*If the documents have been made available under an Open Content Licence (especially Creative Commons Licences), you may exercise further usage rights as specified in the indicated licence.*

July 2021

# Developments in the 'LNG to Power' market and the growing importance of floating facilities

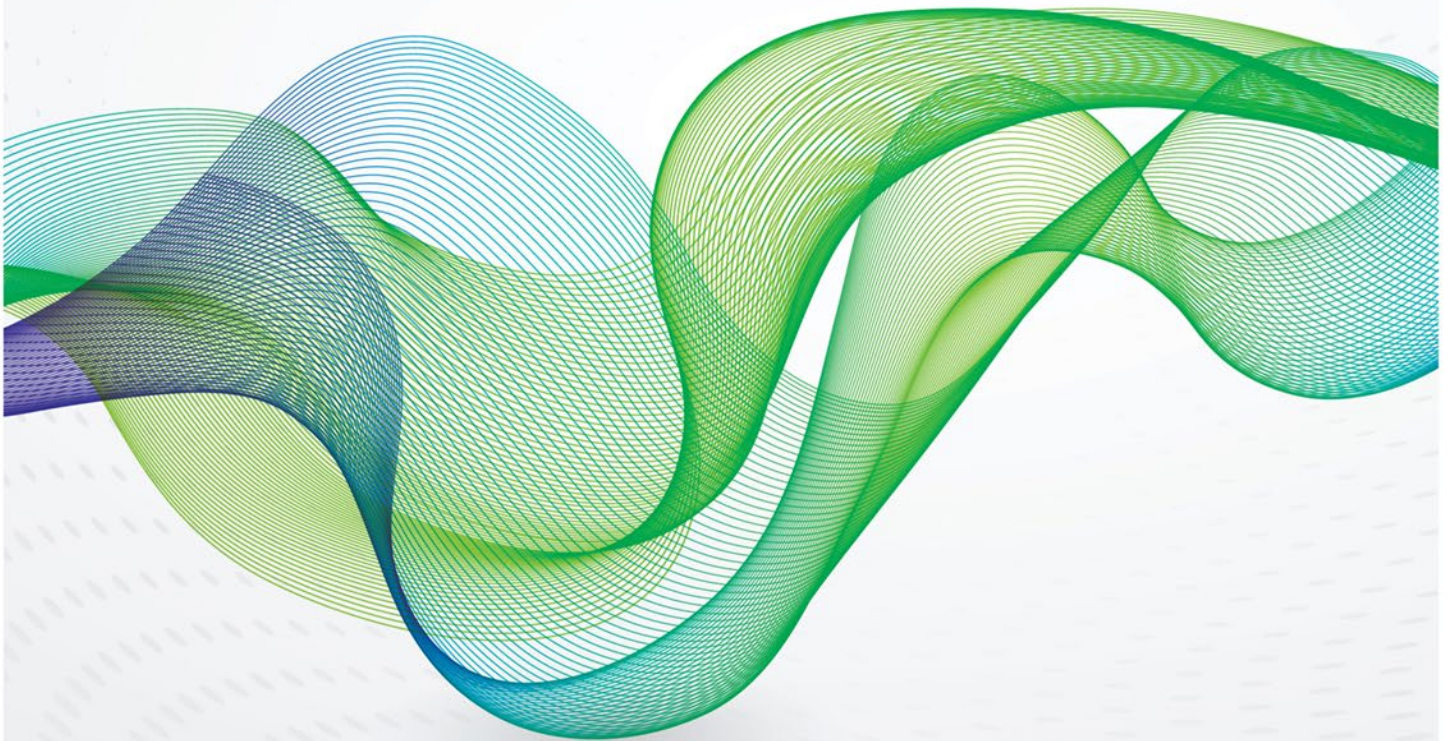

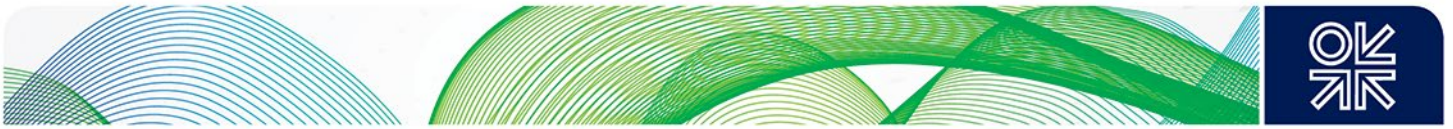

The contents of this paper are the author's sole responsibility. They do not necessarily represent the views of the Oxford Institute for Energy Studies or any of its members.

*Copyright © 2021*

**Oxford Institute for Energy Studies**

(Registered Charity, No. 286084)

This publication may be reproduced in part for educational or non-profit purposes without special permission from the copyright holder, provided acknowledgment of the source is made. No use of this publication may be made for resale or for any other commercial purpose whatsoever without prior permission in writing from the Oxford Institute for Energy Studies.

ISBN 978-1-78467-181-5

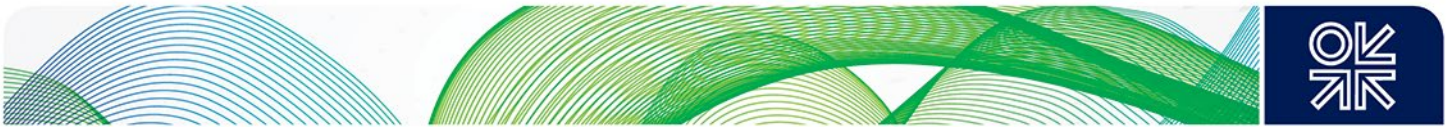

## Contents

Figures .....	ii
Tables.....	iii
1. Introduction and context.....	1
2. History of floating LNG to power .....	1
3. Technical background .....	2
3.1 LNG storage.....	3
3.2 LNG regasification.....	4
3.3 Power generation .....	5
4. Options for system configurations.....	6
4.1 Type 1 – onshore storage tank, vaporiser and power station.....	6
4.2 Type 2 – floating storage unit (FSU), onshore vaporiser and power station .....	6
4.3 Type 3 – floating storage and regasification unit (FSRU) and power station .....	7
4.4 Type 4 – FSRU and floating power plant (FPP) .....	7
4.5 Type 5 – FSRP (floating storage, regasification and power generation).....	8
5. The developing ‘LNG to Power’ market .....	9
6. Technical analysis for reference case project.....	12
6.1 Technology readiness level (TRL) .....	12
6.2 Safety and risk assessment .....	13
6.3 Choice of regasification system .....	14
6.4 Choice of power generation system.....	14
6.5 Reliability and availability .....	15
6.6 Load profile and fuel efficiency .....	15
6.7 Ambient air temperature.....	16
6.8 Heat integration.....	17
6.9 Environmental emissions .....	18
6.10 Regulatory (Permits) .....	20
6.11 Technical summary .....	20
7. Commercial analysis for reference case project.....	21
7.1 Capital cost .....	21
7.2 Operating cost.....	21
7.3 Project schedule.....	22
7.4 LCOE.....	22
8. Conclusions.....	23
Glossary .....	26

## Figures

Figure 1: LNG to Power options.....	3
Figure 2: LNG to power configurations .....	6
Figure 3: FSRP schematic .....	9
Figure 4: Impact of power load on average generator loading .....	16
Figure 5: Impact of ambient air temperature on power output.....	17
Figure 6: FSRP glycol IFV heat integration schematic .....	18
Figure 7: LCOE comparison between FSRP and FSRU+FPP solutions.....	22

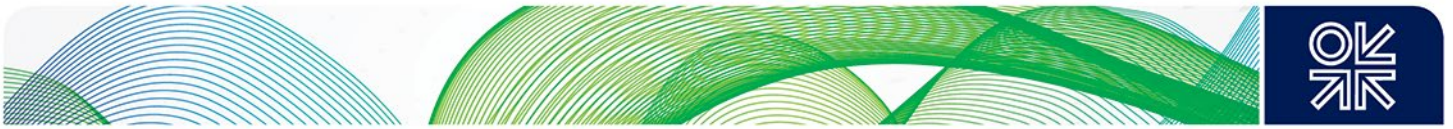

## Tables

Table 1: Types of LNG to Power systems .....	9
Table 2: Comparison of Type 4 and Type 5 Systems .....	12
Table 3: Technology Readiness Level comparison .....	13
Table 4: Comparison of CO <sub>2</sub> emissions .....	19
Table 5: Comparison of heat loads .....	19
Table 6: Reciprocating gas engines – pros and cons .....	20
Table 7: Gas turbines – pros and cons .....	21
Table 8: FSRU + FPP – pros and cons .....	24
Table 9: FSRP – pros and cons .....	24



## 1. Introduction and context

Land-based LNG import terminals were introduced in the 1960s to import LNG from the first liquefaction plants in Algeria and the USA and dispatch gas into national distribution grids. Since then, some 150 LNG import terminals have been built around the world.<sup>1</sup>

In the last 20 years there has been a growth in the number of floating offshore facilities; mainly for oil and gas production as well as LNG storage and regasification, and now also for LNG liquefaction. Floating facilities for importing LNG have become popular since they can generally be deployed more quickly and at a lower cost than onshore facilities.

In the power generation business, the same trend has become visible in the last 10 years, with several floating power plants being deployed, mainly in emerging markets, which use gas fuel to reduce emissions.

The subject of this paper is the overlap between these two worlds, where floating facilities are used to provide new 'LNG to Power' capacity. This is relevant in today's highly competitive market, where floating solutions that offer cost and schedule advantages over traditional land-based facilities are of growing interest.

The paper builds on the 2019 OIES paper 'Floating LNG Update'<sup>2</sup> and discusses the latest technology developments (including floating power plants - FPPs), compares options, and identifies the benefits and drawbacks, both technical and commercial, of the leading available solutions.

Acronyms used in this report are defined in the Glossary.

## 2. History of floating LNG to power

FPPs can be either ship-shaped vessels or flat barges, and over 70 such vessels have been built, with most operating on liquid fuel. One of the earliest FPP vessels was the SS Jacona, which was built in 1931 to restore power to communities after storm damage.<sup>3</sup> The concept was further developed by the US Navy and Army during World War II, and since then it has developed into a popular way of providing energy to developing markets.

As the FPP business grew, multiple options became available:

- **Hull** – Ship shaped or flat barge.
- **Generators** – Gas turbines or reciprocating engines, both being available in either simple cycle or combined cycle.
- **Fuel Choice** – HFO, MDO, Natural Gas.
- **Contract** – EPCI, Lease & Operate, PPA.

Today, the power generation industry is under growing pressure to reduce emissions and at the same time remain competitive with renewable energies. This is driving three important changes:

- a) A switch to gas fuel, including LNG, to reduce emissions.

---

<sup>1</sup>The LNG Industry GIIGNL Annual Report, 2020 [https://giignl.org/sites/default/files/PUBLIC\\_AREA/Publications/giignl\\_-\\_2020\\_annual\\_report\\_-\\_04082020.pdf](https://giignl.org/sites/default/files/PUBLIC_AREA/Publications/giignl_-_2020_annual_report_-_04082020.pdf)

<sup>2</sup><https://www.oxfordenergy.org/wpcms/wp-content/uploads/2019/09/Floating-LNG-Update-Liquefaction-and-Import-Terminals-NG149.pdf?v=7516fd43adaa2>

<sup>3</sup><https://en.wikipedia.org/wiki/Powership>

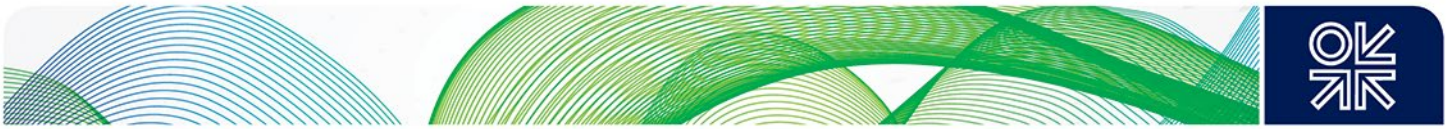

- b) The use of more fuel-efficient power generation technology to reduce OPEX.
- c) Pressure to optimize CAPEX and OPEX, to remain competitive.

The move towards LNG to power projects, and especially floating LNG to power, is growing in importance since it can help to address all three of these challenges simultaneously. LNG is the cleanest fossil fuel for power generation, and the latest generation of combined-cycle generator systems can achieve very high fuel efficiencies. Floating options for LNG storage, regasification and power generation can be more competitive than traditional land-based solutions, can be leased to reduce the capital intensity of projects and can be delivered faster with fewer permitting issues.

The first FSRU (floating storage & regasification unit) was introduced in 2005, and since then these vessels have been widely utilized for LNG import terminals, both to supply gas distribution grids and to feed local power stations. There is now a global fleet of vessels available for charter at short notice, making the FSRU attractive for rapid deployment with limited capital outlay.

Initially, FSRUs were seen as 'new technology', but these were quickly accepted and have now become a standard part of the LNG value chain. The ability to easily relocate vessels to a new location has encouraged speculative building and chartering of vessels – around 85 per cent of the global FSRU fleet (units operating and under construction) is contracted on a charter basis.<sup>4</sup>

Now, the power generation part of some 'LNG to Power' projects is also moving onto floating facilities. This paper explores the latest technologies in the 'LNG to Power' business and investigates the growing role of floating systems in this market.

### 3. Technical background

Converting LNG to electrical power requires three process steps:

- a) Receive the LNG from a transport ship and store it until required as fuel.
- b) Regasify the LNG – convert it from liquid to gaseous form at the required pressure and temperature.
- c) Use the gas as fuel to generate electric power at the voltage and frequency required by the local power distribution grid.

In each of these steps, there is a range of options available, as summarized in **Figure 1**, with many factors to be optimized for each project. These are discussed in more detail in the following sections.

---

<sup>4</sup> Author's research

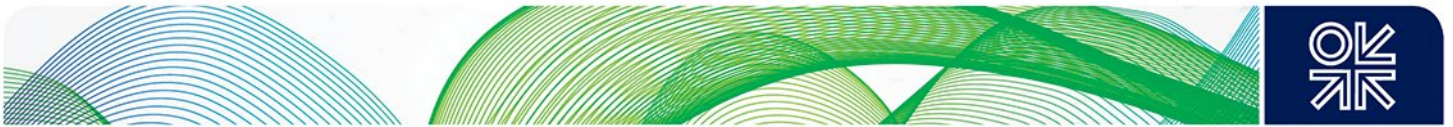

**Figure 1: LNG to Power options**

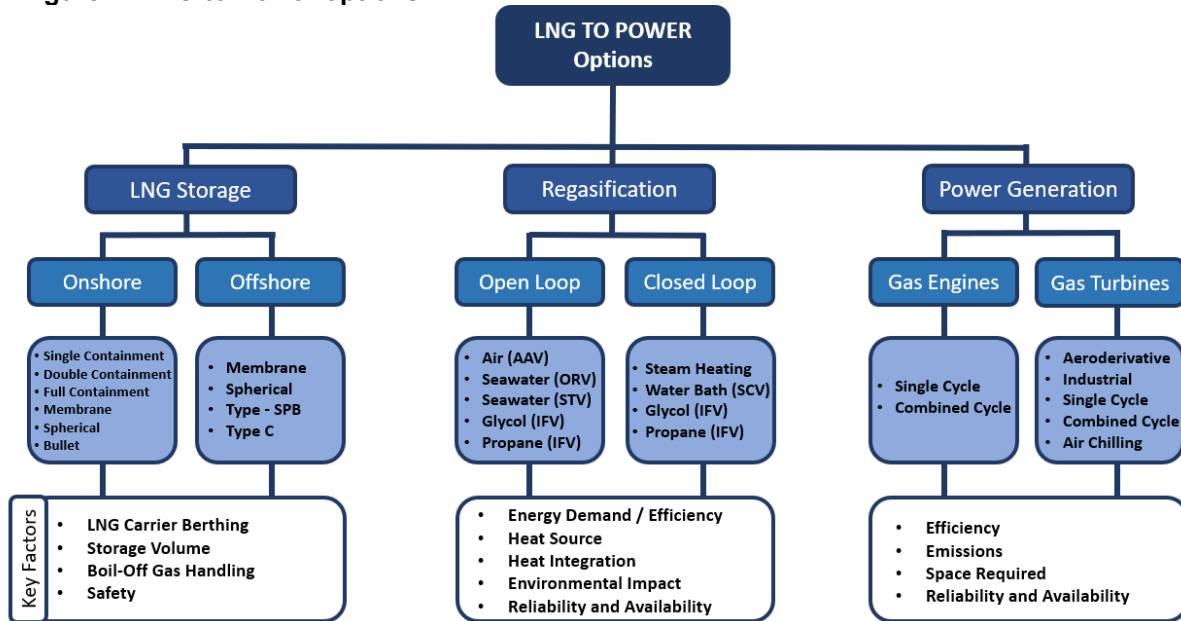

Source: Author's analysis

### 3.1 LNG storage

LNG is traditionally received from an LNG carrier berthed at a jetty and then transferred to onshore LNG storage tanks. The jetty will be sized to moor the expected range of ships, and the storage tank or tanks will have the capacity to accommodate the largest expected LNG parcel size. For larger plants, LNG storage will be in cryogenic membrane or self-supporting tanks, whereas spheres or bullets may be used for smaller plants. A key safety feature of these onshore tanks is the spill containment system, where various options are available for the level of protection, depending on the tank location and the local risk profile.

Alternatively, LNG can be received directly from LNG carriers into a second floating unit which is also moored at a jetty or in open sea near to shore. This may be a floating storage unit (FSU), which is typically a converted tanker, or a floating storage and regasification unit (FSRU), being either a converted tanker or a new build vessel. Again, a range of tank technologies exists including membrane, spheres, IMO Type B (e.g. IHI SPB), or IMO Type C. For the most recent LNG carriers and FSRUs, membrane technology dominates, although the SPB technology is also attractive as it can be more robust for FSRU (and FLNG) operations. For converted FSRUs existing tankers with Moss type, spherical storage tanks are a popular starting point, as the tanks are again robust and have an excellent reliability record.

When an FSU or FSRU is used for storage the LNG carrier will either moor alongside the vessel and transfer cargo by ship-to-ship transfer or, in the case of a jetty, the LNG carrier may moor at an adjacent berth to transfer the cargo over the jetty. For both onshore or floating LNG storage, the tanks must be equipped with a dedicated boil off gas (BOG) system which can re-process the LNG vaporised during the cargo transfer operation, plus the gas which evaporates due to ambient heat ingress into the storage tank(s).

Onshore terminal storage tanks will typically be able to receive the full capacity of a modern LNG carrier with a comfortable working margin. As the size of LNG carriers has increased over the years, so has the average tank capacity in onshore terminals. New terminals built in the last 10 years have an



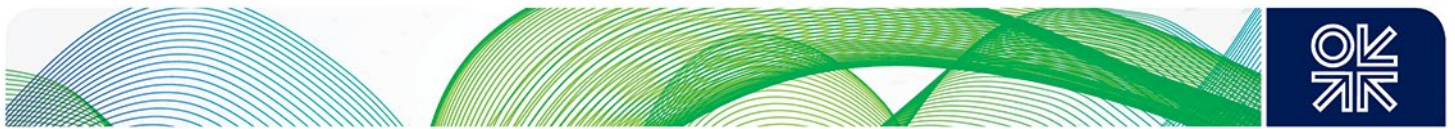

average of 377,000 m<sup>3</sup> of LNG storage capacity,<sup>5</sup> which compares to the largest LNG tankers - the 14 Q-Max vessels of 266,000 m<sup>3</sup> which were delivered between 2008 and 2010.

In contrast, FSU and FSRU hulls are typically based on LNG carrier technology, and available storage capacity in service ranges from 145,000 to 174,000 m<sup>3</sup>, and averages 168,000 m<sup>3</sup>. Only one FSRU has a capacity above 180,000 m<sup>3</sup> (FSRU Challenger, at 263,000 m<sup>3</sup>).<sup>6</sup> This smaller storage capacity for floating systems can make LNG carrier logistics more difficult, and the operator may risk incurring a price penalty if a partial LNG cargo needs to be offloaded from a large LNG carrier.

### 3.2 LNG regasification

The LNG regasification system uses a heat source to convert liquid LNG into a gas, at the required export pressure, and then to heat the gas to the required export temperature.

Two types of regasification processes are available – open-loop and closed-loop. Open-loop relies on heat transfer from an ambient heat source to the LNG in a once-through arrangement, whereas closed-loop uses waste heat, boilers or fired heaters to heat a recirculating stream of heating fluid.

For small capacity systems, ambient air vaporisers (AAV) can be used in the open-loop to vaporise the LNG. Liquid LNG is pumped to the required pressure and is passed through a heat exchanger in the form of a rack of tubes, across which air is blown. Heat is transferred from the warm air to the cold LNG. For larger plants, open-loop systems may use seawater in an open rack vaporiser (ORV) where the seawater is cascaded over the outside surface of the heat exchanger vertical tubes, through which the pressurised LNG is passed. The seawater transfers heat to the LNG which then vaporises. Alternatively, a shell and tube vaporiser system (STV) can replace the ORV with conventional heat exchangers, through which treated seawater passes in a once-through configuration.

All three of these open-loop systems may have environmental impact issues. The AAV can cause fogging in humid air and is therefore typically only used for small capacities or peak shaving. The ORV and STV may require the use of chemicals (hypochlorite and/or biocides) to control biofouling, and they return cold seawater to the marine environment. For these reasons, closed-loop regasification systems may be preferred to open-loop systems in environmentally sensitive areas or may be mandated by local regulations.

Closed-loop regasification systems use the circulation of an intermediate fluid to perform the heat transfer to the LNG in a process known as intermediate fluid vaporisation (IFV). A water/glycol IFV loop can be used to heat the LNG via a heat exchanger, where the water/glycol is in turn heated by steam from boilers or low-grade waste heat from the power plant.

A propane loop can also be used as an intermediate fluid, where propane is vaporised against a heat source such as steam or low-grade waste heat from the power plant, and the propane is then recondensed against the LNG stream to provide the heat for vaporisation. Propane IFV is more compact than glycol IFV but introduces an additional safety hazard due to a large propane inventory.

Finally, the submerged combustion vaporiser (SCV) process has been widely used onshore where the LNG is vaporised in a hot water bath, and the water is heated by burning some of the gas.

For closed-loop systems around 1.5 per cent of the LNG stream may be consumed as fuel for heating, making them relatively high OPEX solutions. However, if low-grade waste heat is used as a heat source, this fuel consumption can be avoided. The use of heat integration between the power plant and the

---

<sup>5</sup> The LNG Industry GIIGNL Annual Report, 2020 [https://giignl.org/sites/default/files/PUBLIC\\_AREA/Publications/giignl\\_-\\_2020\\_annual\\_report\\_-\\_04082020.pdf](https://giignl.org/sites/default/files/PUBLIC_AREA/Publications/giignl_-_2020_annual_report_-_04082020.pdf)

<sup>6</sup> Author's research

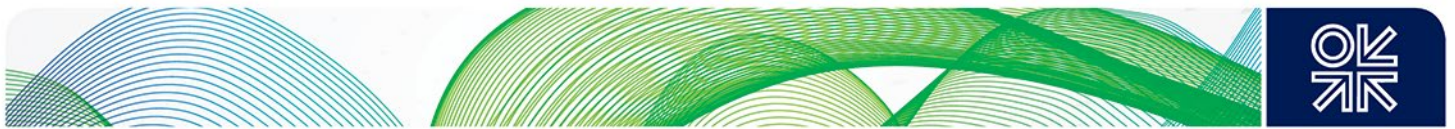

regasification unit, therefore, brings benefits, as discussed in section 6.7, which can reduce OPEX and also minimize the environmental impact of the regasification process.

For FSRU projects, IFV has become the common choice, using either water/glycol or propane as the intermediate heating fluid depending on the available space. The choice of open or closed-loop heating depends on the environmental conditions and local restrictions at the FSRU location. Some FSRUs are equipped for open-loop, or closed-loop, or a hybrid combination of both, to give added flexibility so that the optimum solution can be selected depending on the FSRU location.<sup>7</sup>

### 3.3 Power generation

The choice of the optimum power generation system for an ‘LNG to Power’ project is complex and involves many factors.

These include:

- CAPEX.
- OPEX.
- Fuel efficiency.
- Reliability and availability.
- Environmental conditions on-site and local emissions regulations.
- The required speed of response to load changes.
- Ambient temperature profile.
- Space required.

The combination of these factors will have a direct impact on the levelized cost of electricity (LCOE) calculations for the ‘LNG to Power’ system.

Two types of power generators are widely used – gas turbines (GT) and reciprocating engines (RE). Both can operate either in a basic simple cycle (SC) or in a combined cycle (CC) mode where the exhaust gas heat is used to generate steam for additional power generation.

Reciprocating engines are available in capacities up to around 20 MW per machine and have relatively high fuel efficiency in SC mode, with the option of further improving this (by a small amount) by the addition of a combined steam cycle. These engines are large and heavy, so are difficult to integrate on FPPs, but they do offer good flexibility for small to medium-sized power generation plants up to around 500 MW. Leading suppliers are Wartsila and MAN Energy.

Gas turbines are available from several suppliers in a wide range of capacities as either industrial or aero-derivative models. For onshore plants, high-efficiency industrial machines are typically used in a combined cycle configuration. For floating systems, aero-derivatives are often preferred as they are more compact, lighter and more motion tolerant, although some industrial machines have also been adapted to work well in these conditions. With a combined cycle, fuel efficiencies can exceed 60 per cent at full load conditions. However, to achieve this, a waste heat recovery system and steam turbine are needed, which for larger plants can require a massive cooling water flow for the steam condenser, causing potential environmental impact issues. Leading gas turbine suppliers are Siemens, Baker Hughes/GE, Hitachi, Mitsubishi, Kawasaki, Solar and Ansaldo/Shanghai Electric.

---

<sup>7</sup> <https://exceleerateenergy.com/fleet/>

## 4. Options for system configurations

Five different types of ‘LNG to Power’ configurations are considered using the above three building blocks. These are summarized in **Figure 2** and described in the following sections.

**Figure 2: LNG to power configurations**

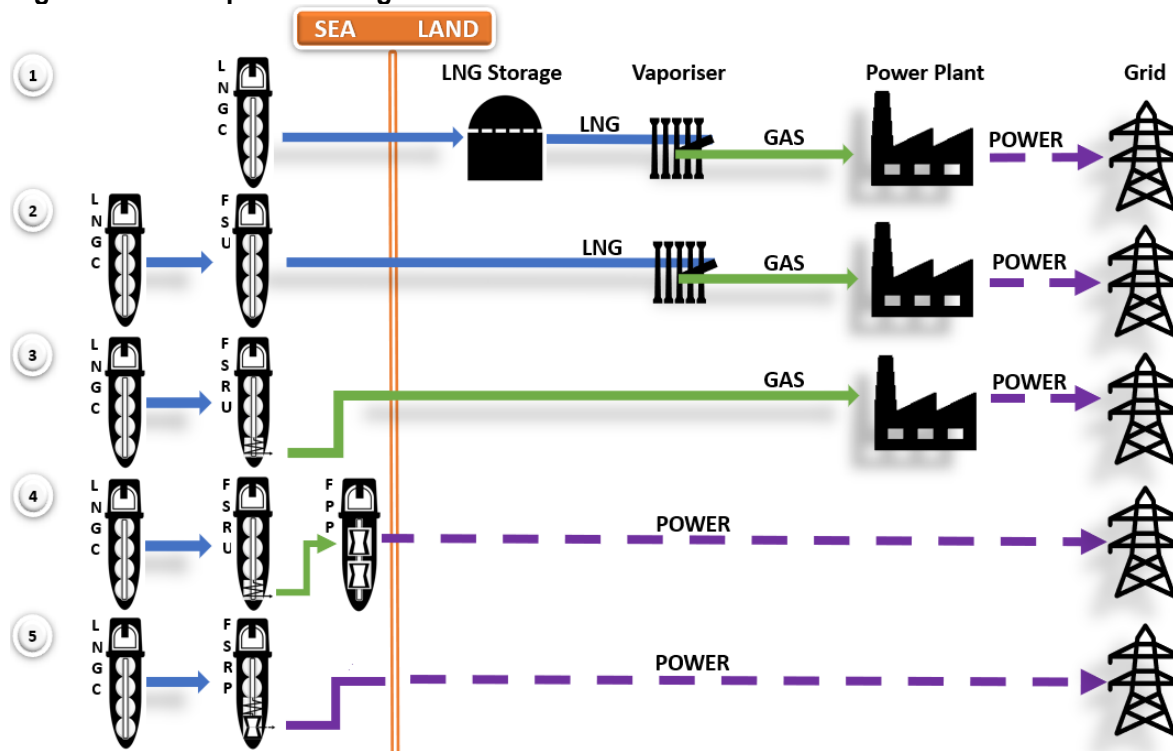

Source: Author's analysis

### 4.1 Type 1 – onshore storage tank, vaporiser and power station

This configuration is a conventional onshore LNG receiving terminal feeding a gas-fired power station. The LNGC (LNG carrier) discharges into the onshore LNG storage tanks, with their dedicated BOG system.

The LNG from the tanks is pumped to the required export pressure, vaporised and then supplied to the power station as fuel gas. In this configuration the power plant may be the sole consumer, or the terminal may also supply other consumers (e.g. petrochemical plants) and/or a gas distribution grid.

### 4.2 Type 2 – floating storage unit (FSU), onshore vaporiser and power station

In this configuration, the LNG storage is moved from onshore to an LNG FSU permanently moored at a jetty. LNG from the FSU is transferred to the onshore vaporiser using pumps on the FSU, which feeds fuel gas to the onshore power plant.

The FSU is typically an LNGC which requires minimal conversion for this application. The first LNG FSU was deployed in Chile by BW Offshore in 2010, although not for power generation purposes.<sup>8</sup> The most recent LNG FSU directly feeding a power station is a converted Moss tanker moored at the

<sup>8</sup> <https://www.euro-petrole.com/qdf-suez-renforce-sa-flotte-de-navires-methaniers-n-f-3507>

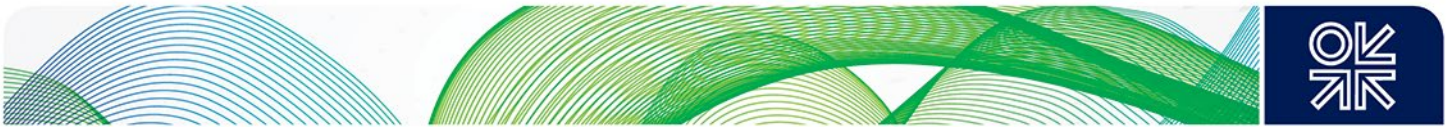

Delimara power station in Malta.<sup>9</sup> To improve overall efficiency and reduce OPEX, the FSU may receive electric power directly from the onshore power station, as is the case in Malta.

### 4.3 Type 3 – floating storage and regasification unit (FSRU) and power station

In this configuration, compared to Type 1, both the LNG storage and the vaporiser are moved from onshore to an FSRU permanently moored at a jetty, or a nearshore mooring. Gas from the FSRU is supplied at the required pressure as fuel to the onshore power plant, plus an onshore grid if required. This has become a common scheme in many countries worldwide. There are currently 25 FSRUs in service and 15 more under construction, and of this total of 40 vessels, around 17 are or will be employed to directly supply an onshore power station.<sup>10</sup> In addition, a further 12 FSRUs are currently trading as LNG carriers, or are on standby.



Courtesy of Höegh

Again, to improve efficiency, the FSRU may be powered directly from the power station.

Leading suppliers in the FSRU business are:

- a) FSRU contractors – Hoegh, Excelerate, Golar/New Fortress Energy, MOL, BW Gas.
- b) FSRU delivery shipyards – Samsung, DMSE, HHI, Hudong, Wison, Keppel (for conversions).

### 4.4 Type 4 – FSRU and floating power plant (FPP)



Courtesy of Karpowership

Type 4 is a further progression of Type 3, where the onshore power plant is replaced by an FPP, being either a power barge or a powership located at a jetty or spread moored near shore, which is supplied with fuel by an FSRU.

High Voltage (HV) power cables connect the FPP to the onshore grid via a local substation.

The FSRU and FPP may be located at a common jetty, where gas is transferred from the FSRU to the FPP over the jetty. Alternatively, the FSRU may be moored offshore, and gas transferred to the FPP by pipeline.

Many FPPs are in operation, and the vast majority are currently running on liquid fuel. However, with increased environmental pressure and the availability of low-cost LNG, some of these units are now being converted to gas fuel. Several power barges and two powerships have already been converted to gas fuel, but these take fuel from the gas distribution grid and not a dedicated FSRU.<sup>11</sup> The first project to convert a powership to LNG fuel is underway<sup>12</sup> and several similar projects are now being planned.

<sup>9</sup> <https://www.bumiarmada.com/our-services/#fpo>

<sup>10</sup> Author's research

<sup>11</sup> <https://cdn.wartsila.com/docs/default-source/Power-Plants-documents/reference-documents/brochures/floating-power-plants-2011.pdf>

<sup>12</sup> <https://www.mol.co.jp/en/pr/2021/21017.html>

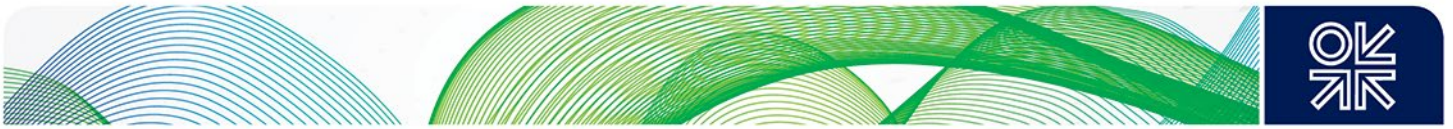

Leading suppliers in the FPP business are:

- a) Powership – Karpowership.
- b) Power barges – Waller Marine, Wartsila, MAN, Siemens, BWSC/TGE.

#### 4.5 Type 5 – FSRP (floating storage, regasification and power generation)

In the final configuration, the FSRU and FPP are combined into one integrated floating structure, the FSRP, where the power generation system and associated switchgear are located on the vessel deck, as is commonly done for an FPSO or FLNG vessel. This may be either a new build vessel, using

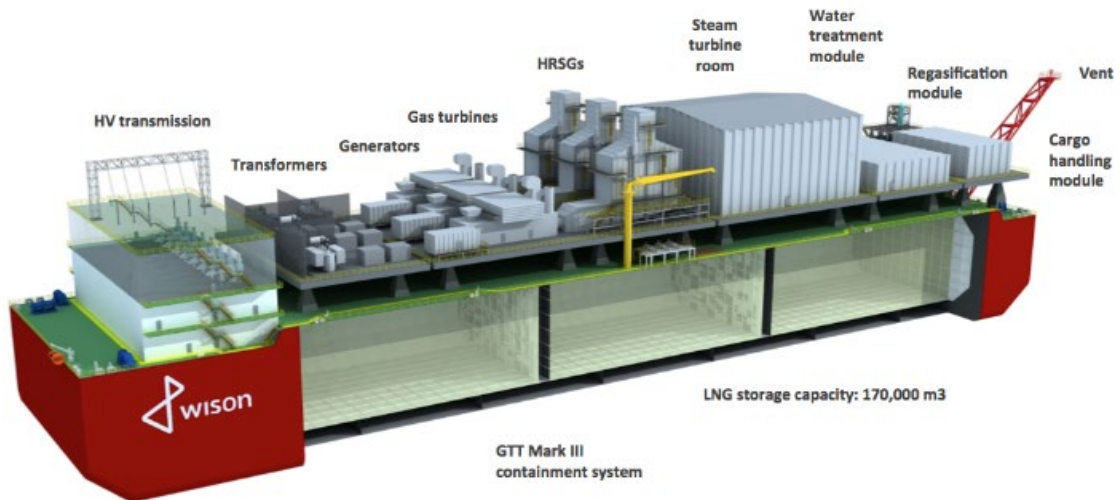

Courtesy of Wison

Membrane or SPB type tanks<sup>13</sup> or a converted vessel, such as a Moss tanker, where at least one sphere is removed to make space for the power plant.<sup>14</sup>

This concept has been extensively studied and several concepts have obtained Classification Society Approval in Principle (AIP)<sup>13,15</sup> but no project has yet been fully sanctioned.<sup>16</sup>

**Figure 3** shows a schematic of a typical FSRP design, which comprises FSRU and power plant systems integrated into one vessel. Combining these on a single hull brings the opportunity for CAPEX and OPEX synergies. Moreover, this option brings the possibility of heat integration, where waste heat from the combined cycle steam system can be used for regasification, and cold energy recovered from regasification can be used for gas turbine inlet air chilling. This is discussed in section 6.8 below.

<sup>13</sup> Wison's 300MW FSRP Gets AiP from Lloyd's Register - Offshore Energy ([offshore-energy.biz](http://offshore-energy.biz))

<sup>14</sup> <https://www.modec.com/business/floater/fsrwp/>

<sup>15</sup> Gastech 2020, 'Integrated LNG to power: where the two worlds plug and play', Renaud Le Dévéhat, Director R&D, Technip France

<sup>16</sup> The purpose of a Classification Society is to provide classification and statutory services and assistance to the maritime industry and regulatory bodies as regards maritime safety and pollution prevention, based on the accumulation of maritime knowledge and technology

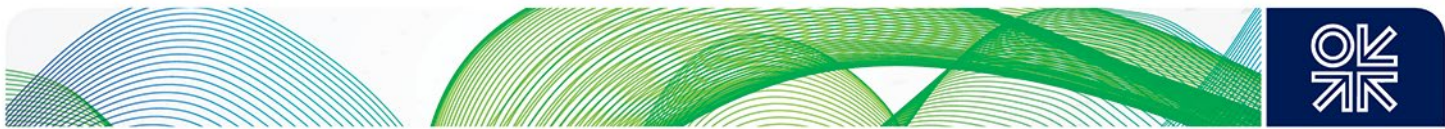

**Figure 3: FSRP schematic**

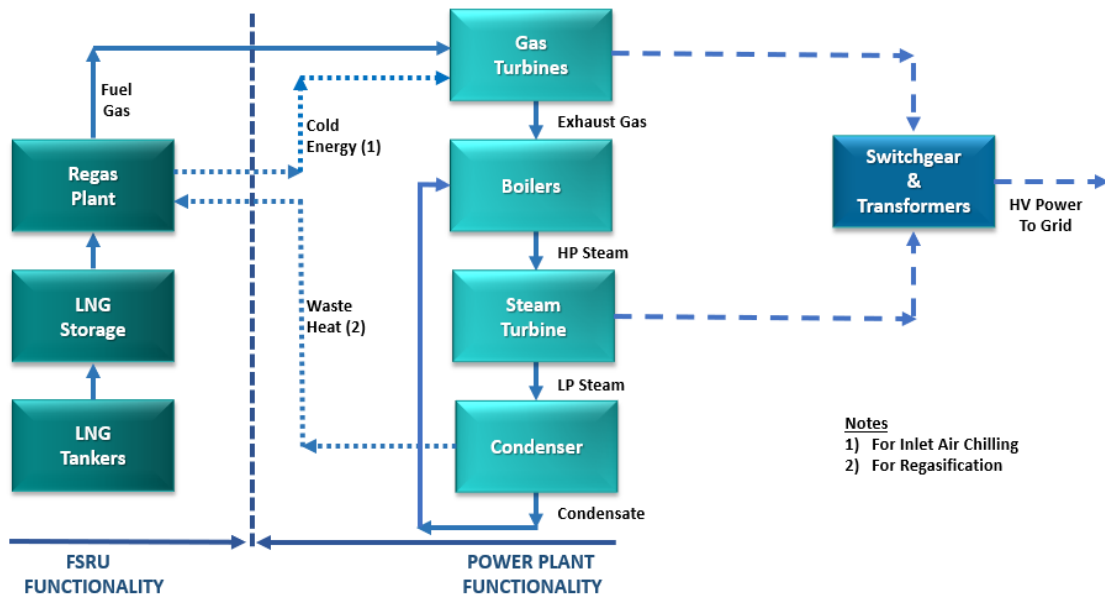

Source: Author's analysis

Leading suppliers in the FSRP business are:

- a) FSRP lease contractors – Potentially MODEC, SBM Offshore, Golar / New Fortress Energy.
- b) FSRP EPC delivery – Technip, Chiyoda, Wison, HHI, IHI, Kawasaki.

### 5. The developing 'LNG to Power' market

The following table summarizes the approximate number of each of the five types of 'LNG to Power' systems described above, which are currently in operation.

**Table 1: Types of LNG to Power systems**

Systems & Components	First Application	Number in Service	Status
<b>Type 1</b> - Onshore Storage Tank, Vaporiser and Power Station	1969	Around 125 in total	The first land-based import terminals were built in Spain and Japan in 1969. There are now around 125 in operation, with several more planned or under construction. Some of these are directly feeding gas distribution grids, but many feed power stations with at least part of their output.
<b>Type 2</b> – FSU, Onshore Vaporiser and Power Station	2012	3 for Power Generation, 5 in total.	First LNG FSU deployed in Chile in 2010. The first dedicated FSU for a power plant was installed in Malta in 2017. All have separate regasification units which are either located onshore, jetty mounted, or on a separate barge.

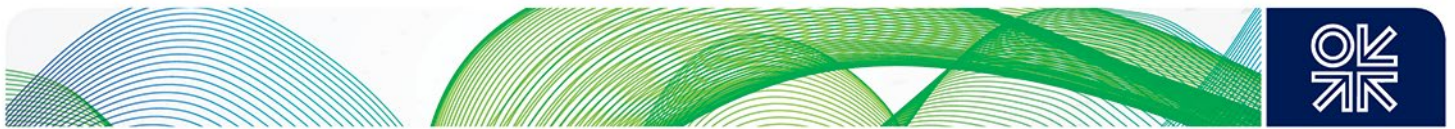

<b>Type 3 – FSRU and Power Station</b>	2005	12 (17)	There are 25 FSRUs operating worldwide and 15 more under construction. Of these, 12 directly feed power stations with a further 5 similar projects under construction. <sup>17</sup>
<b>Type 4a – FSRU and FPP (Power Barge)</b>	2013	0	Over 50 power barges are operating worldwide, but mainly on liquid fuel. Some have now been converted to gas fuel, such as the NEPC Haripur Ltd 120MW barge. But no examples were found of an FSU or FSRU directly feeding a Power Barge.
<b>Type 4b – FSRU and FPP (Power Ship)</b>	2020	1	19 Powerships are operating worldwide, mainly on liquid fuel. The Karadeniz Powership Zeynep Sultan in Indonesia was the first to be converted from liquid fuel to LNG in 2020, fed from a dedicated FSRU. <sup>18</sup> More are planned to follow.
<b>Type 5 – FSRP</b>	Pending FID	0	Several integrated FSRP units are under study and evaluation, but none have yet passed FID.

Source: Author's analysis

The conventional Type 1 onshore LNG terminal and power plant are clearly the most widely used, for historical reasons. But there is now a trend towards wider use of floating systems, especially for smaller capacity plants, instead of fixed onshore infrastructure. Several reasons are driving this change:

- Faster delivery schedule.
- Lower CAPEX.
- The ability to charter the facilities - less capital intensive for the client.
- Easier permitting.
- Lower risk for local population onshore.
- Easier to upgrade as the electricity load profile changes.

Since the introduction of FSRU technology in 2005, there has been a steady increase in the number of import terminals using this technology instead of a conventional onshore plant. Whereas around 15 per cent of existing LNG import terminals are now based on floating systems, these make up a much larger share of new or planned projects, at around 30 per cent.<sup>19</sup>

The driver behind this shift is that FSRUs have many advantages over fixed onshore terminals.<sup>20</sup>

#### a) Cost and schedule

- Construction or conversion costs for a large FSRU based terminal are typically in the region of \$450 million, whereas an equivalent onshore terminal can cost \$750 million<sup>21</sup> (based on 2017 prices for a three mtpa plant with a single 180,000 m<sup>3</sup> storage tank).

<sup>17</sup> Author's research

<sup>18</sup> <https://www.rambuenergy.com/2020/09/karpowership-launches-1st-lng-to-power-project-in-indonesia/>

<sup>19</sup> OIES - LNG in Europe 2018 - An Overview of LNG Import Terminals in Europe <https://www.oxfordenergy.org/publications/>

<sup>20</sup> IGU FLNG Report, IGU LNG Committee, 2015-2018, adapted by Author, <https://www.igu.org/resources/flng-report-2015-2018/>

<sup>21</sup> Songhurst B. (2017). 'The Outlook for Floating Storage and Regasification Units', NG123, OIES

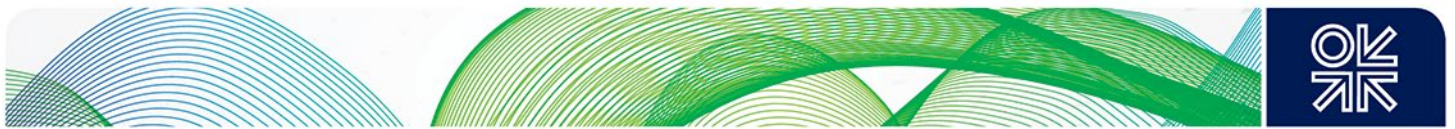

- An FSRU CAPEX benefits from a standardized product built in a controlled Far East shipyard environment, whereas onshore terminals require a 'stick-built' approach in locations that may be remote and/or with high local labour costs.
- FSRU conversion can be completed in about 18 months, or three years for a new build. In contrast, a greenfield onshore terminal may take between three to five years.
- There is a pool of existing FSRUs available for charter at short notice – vessels which are trading as LNG carriers or are idle on standby. If one of these is suitable for a project, the schedule may be driven only by the time needed to prepare the mooring and gas connection pipeline.

#### **b) Regulatory and permitting issues**

- FSRU projects can generally complete permitting much faster than that required to build a permanent onshore LNG terminal.
- The environmental impact should be lower, especially if the FSRU can be placed in an open sea or nearshore location.

#### **c) Quality**

- An FSRU should have higher quality due to its fabrication in a controlled shipyard environment instead of using temporary labour on a remote site.

#### **d) Flexibility**

- The FSRU can be moved at the end of a project to a new location, allowing the CAPEX to be depreciated over more than one project.
- The FSRU can also be moved in case of early contract termination or default, which can help to mitigate project risk.
- The FSRU can be moved when required to respond to global changes in gas demand.
- The FSRU can be chartered to reduce the level of investment required.

For the power plant, it is important to note that most of the benefits listed above for FSRUs can be equally applied to other floating systems, namely, FPPs and FSRPs:

- Lower CAPEX from fabrication in a Far East shipyard environment.
- Faster schedule.
- Ability to charter the facility.
- Ease of relocation.
- Simpler upgrade options.
- Better quality due to fabrication in a controlled shipyard environment.

In the future, for small to medium-sized 'LNG to Power' projects up to around 1.0 GW, an increase in the use of FSRU + FPP and integrated FSRP vessels is expected.

For larger projects above 1 GW, a continued growth in the use of FSRUs for storage and regasification, coupled with an onshore power plant, is expected. The BW Magna FSRU in the Port of Acu, Brazil, which today supplies the 1.3 GW GNA 'LNG to Power' project, and which will soon be expanded to 3.0 GW with the addition of a second power plant, is an example of such a scheme.<sup>22</sup> The main prospects for new floating 'LNG to Power' projects are currently in South Africa, Central and South America, and

---

<sup>22</sup> <https://www.seatrade-maritime.com/ports-logistics/bw-fsr-arrives-brazil-port-acu-lng-power-project>





Southeast Asia (such as Cambodia and Vietnam). These new projects are typically driven by the need for a rapid and competitive solution to meet growing power demand, and the increased pressure to accelerate phasing out of coal-fired power generation.

## 6. Technical analysis for reference case project

Given the expected growth in the use of floating facilities for 'LNG to Power' projects, the main technical differences between the two leading contenders for a floating scheme, based on two of the schemes outlined above, are compared:

- **Type 4** – FSRU and FPP.
- **Type 5** – Integrated FSRP.

A typical 'LNG to Power' project as a Reference Case has been selected and the following technical requirements have been assumed. The following sections discuss the technical comparison of these two options.

**Table 2: Comparison of Type 4 and Type 5 Systems**

	Scenario 1 - 2 Vessels		Scenario 2 – 1 Vessel
<b>Power Demand (MW)</b>	Variable, from 50 min to 450 max, 50 Hz		
<b>Location</b>	Remote, Tropical Climate		
	<b>FSRU</b>	<b>FPP</b>	<b>FSRP</b>
<b>Generators</b>		Gas Engines + Combined Cycle	Gas Turbines + Combined Cycle
<b>Model Assumed</b>		Wartsila 18V50SG	Siemens SGT-800
<b>Capacity per engine (MWe)</b>		18.35	55.4
<b>Fuel Rate CC (kJ/kWh) LHV</b>		6922	6360
<b>Fuel Efficiency (CC @ Iso)</b>		52.0%	56.6%
<b>Inlet Air Chilling</b>		No	Yes
<b>Number of Main Generators</b>		24	6
<b>Number of Steam Turbines</b>		1 @ 30 MW	2 @ 58 MW each
<b>Peak Fuel Gas Demand (MMscfd)</b>		72.3	66.4
<b>Hull Type</b>	Ship Conversion	Ship Conversion	New Build Hull
<b>LNG Storage Capacity (m<sup>3</sup>)</b>	125,000		180,000
<b>LNG Storage Capacity (Days)</b>	36.5		57
<b>Heat Integration</b>	No	No	Yes

Source: Author's analysis

For the FPP, a gas engine-based powership instead of a GT based power barge is assumed, to enable direct comparison against the GT-based FSRP. Gas engine-based power barges are generally smaller capacity, so the large powership is more directly comparable to a large FSRP.

### 6.1 Technology readiness level (TRL)

The TRL system was first introduced by NASA as a way of quantifying the maturity of a component or a complete system, to manage project risk. This was later adopted by the oil and gas subsea industry



and was documented in API 17N, published in 2014.<sup>23</sup> It has now been more generally adopted by the offshore oil and gas industry. This API 17N TRL process uses a scale ranging from 1 to 7, where TRL1 is a new idea and TRL7 is a component or system that has operated trouble-free for at least three years. Mid-range, TRL4 represents either a component that has been successfully prototype tested at full scale but has not yet been deployed on a project or a novel system that has completed a full FEED study but has not yet completed the project execution stage.

Comparing the different components of the five types of ‘LNG to Power’ schemes, neither the ship-shaped FPP nor the FSRP has yet achieved TRL7 status.

**Table 3: Technology Readiness Level comparison**

Component	First Application	TRL <sup>24</sup>
FSRU – New Build	2005	7
FSRU – Conversion	2007	7
FPP – Gas fuelled Power Barge	2013	7
FPP – Gas fuelled Power Ship	2019	6
FSRP	Pending	4

Source: Author’s analysis

The Turkish company Karpowership, a part of the Karadeniz Group, is the leading powership supplier, and since 2010 they have provided around 20 vessels with power capacities ranging from 36MW to 470 MW. To date, most are still running on liquid fuel, but three have operated on gas fuel since 2019. The first powership to run on regasified LNG is located in Indonesia and was converted in 2020<sup>25</sup> and is now being fed by a small dedicated FSRU.

Thanks to a recent joint venture (JV) agreement with MOL to create KARMOL, more of the Karpowership FPPs will be paired with FSRUs and fuelled on regasified LNG in future. Although the liquid-fuelled FPP is TRL7, the use of gas as fuel introduces changes to the FPP design, safety and operation, and hence the TRL level of a gas-fuelled FPP drops back from TRL7 to TRL6 until the first unit has been safely and successfully operated for three years – this milestone should be reached in 2022.

For the FSRP, although it is comprised of proven building blocks, no such vessels have yet been built as an integrated product, and hence it is currently rated at TRL 4. Rigorous safety assessments will be required during the execution of the prototype project to convince the relevant stakeholders, including the Classification Society and the local Regulatory authorities in the host country, that the vessel will meet all the necessary standards. Several companies have already obtained AIP from Classification Societies, but more detailed safety analyses will still be required during the execution of the first EPC project. This may extend the project schedule for the prototype and deter some potential clients.

## 6.2 Safety and risk assessment

The use of separate FSRU and FPP vessels allows the physical separation of most of the hazardous and non-hazardous equipment. The LNG loading, storage and regasification systems on the FSRU, which will be classified with several hazardous areas as defined by API 505,<sup>26</sup> will be physically remote from the power generation equipment and switchgear on the FPP, which will mainly be classified as non-hazardous. One exception on the FPP is the fuel gas supply to the gas engines, which must be

<sup>23</sup> API 17N – Recommended Practise for Subsea Production System Reliability, Technical Risk & Integrity Management, 2014

<sup>24</sup> Author’s research based on API 17N

<sup>25</sup> <https://www.offshore-energy.biz/karpowership-kicks-off-first-floating-lng-to-power-project-in-indonesia/>

<sup>26</sup> API RP 505, Recommended Practice for Classification of Locations for Electrical Installations at Petroleum Facilities, 2018

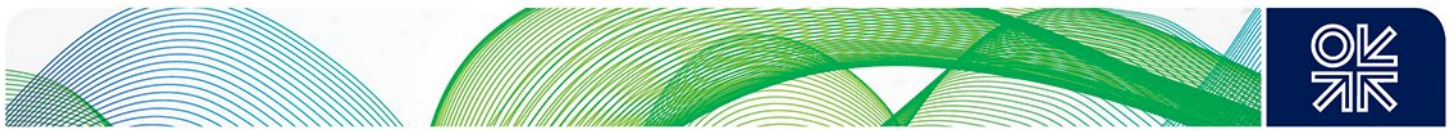

designed to ensure that there is no risk of a gas leak where the gas cloud could enter areas containing equipment that could generate a source of ignition. Where the gas engines are installed in enclosed machinery rooms within the hull, such as on the powership design, then special precautions are required to avoid possible gas leaks into these enclosed spaces. However, this is standard practice in the shipping and offshore industries and is well proven in service. Moreover, there will be an interconnecting gas line from the FSRU to the FPP, which may run over a jetty or subsea, and which will contain a significant volume of gas under moderate pressure. This is another area of risk that must be assessed and carefully managed to minimize any risk of loss of fluid containment.

The FSRP does not benefit from the same inherent risk segregation as the FSRU + FPP option, but the topsides power generation modules can be designed in line with standard offshore practice and specified for a Zone 2 hazardous area location, to minimize the risk of ignition sources.

The LNG loading and regasification systems and the HV power export equipment should normally be located at opposite ends of the vessel to minimize risks from gas leaks. If required by safety studies, blast walls may be added to increase the segregation between hazardous and non-hazardous areas.

Overall, both options should be able to comply with all the required safety standards, but each has specific safety risks that must be carefully managed.

### 6.3 Choice of regasification system

For both Reference Case options, a conventional open-loop glycol IFV heating medium for the regasification system is assumed.

For the FSRU, it is assumed that this is heated by seawater, via the intermediate glycol loop. In this case, there is only a small seawater demand, with cold water returned at 5°C below ambient seawater temperature. In the case of environmentally sensitive areas, the open-loop can be replaced by a closed-loop system to eliminate the seawater heating duty at the expense of fuel gas consumption.

For the FSRP, the assumption is that the glycol is heated by waste heat from the steam system, and periodically also by cooling warm air in the gas turbine inlet air chilling system. So, in normal operation, there is no seawater demand for LNG heating. However, the combined cycle system has a massive seawater demand for steam condensers, which can have a significant environmental impact in closed harbours. Moreover, pumping large volumes of seawater onto the vessel if it is moored in very shallow water can lead to solids fouling the process systems if the seabed soil conditions are unfavourable.

To get around such issues, Technip has proposed an alternative cooling system for their FSRP concept, using wet cooling towers.<sup>27</sup> These require additional space, so Technip proposes to extend the FSRP hull to provide this. Alternatively, the cooling towers could be placed onshore, as has been proposed for some at-shore FLNG projects.

A further alternative is to revert to simple cycle GTs and avoid the steam condenser system and its associated cooling water demand, but with an efficiency penalty.

### 6.4 Choice of power generation system

For this analysis, two different power generation configurations are compared:

- a) An FPP with 24 gas engines and 1 steam turbine in combined cycle mode, with a total installed capacity of around 470 MW, similar to the design used by Karpowership for their Khan Class

---

<sup>27</sup> Gastech 2020, 'Integrated LNG to power: where the two worlds plug and play', Renaud Le Dévéhat, Director R&D, Technip France

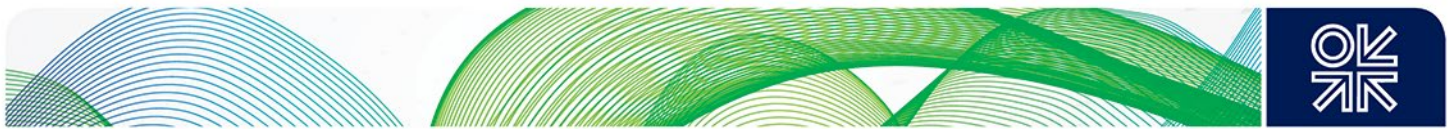

FPP.<sup>28</sup> (Assuming only 450 MW peak power output, with 1 of the 24 gas engines being under maintenance at any time).

- b) An FSRP based on combined cycle gas turbines, with a total installed capacity of around 450 MW. A design similar to the Siemens SeaFloat concept<sup>29</sup> with 6 off SGT-800 gas turbines and 2 off SST-600 steam turbines is used.

Each of these options has pros and cons in different technical and commercial aspects, which are explored in the following sections.

### 6.5 Reliability and availability

The FSRU and the FSRP will typically be provided with a spare regasification skid (i.e. an n+1 configuration) to ensure the high availability of the fuel gas supply.

For the machinery, gas turbine and gas engine suppliers both claim around 98 per cent to 98.5 per cent availability for their equipment, with each requiring similar downtime for planned maintenance at regular intervals.

However, when the FPP is based on gas engines there may be a large number of machines installed. For the 470 MW powerships, for example, there will typically be 24 gas engines, so with one under maintenance, there will still be around 96 per cent of the total power available. For the Reference Case configuration, an annual average of 450 MW power generation is expected to be available.

However, for an FSRP with six gas turbines plus two steam turbines, when one unit is under maintenance there will only be 83 per cent of the total capacity available. Taking an average maintenance requirement of 5.5 days per year (98.5% availability), the annual average power available is calculated as 441 MW, that is, 98 per cent of the installed capacity.

Gas engines also have the advantage that they are easier to maintain using the regular vessel crew, with suitable training, whereas gas turbines are dependent on specialist supplier technicians visiting the unit for planned and unplanned maintenance.

So, in terms of availability, the use of multiple smaller capacity engines is an advantage for the overall system performance.

### 6.6 Load profile and fuel efficiency

Many new power generation projects are linked to the growing electrification of the developing world. In these cases, there is typically a growing power demand over time, as the power distribution grid is expanded, and more consumers are added. The FPP or FSRP, therefore, needs to be able to operate efficiently over a range of power demands.

Both gas engines and gas turbines lose fuel efficiency as the power output drops below full power. Hence, as the power demand from the grid drops, the power plant will typically reduce the number of machines running to keep the remaining machines operating at high efficiency. The FPP with multiple gas engines has more flexibility to manage this process than an FSRP with a smaller number of larger machines.

**Figure 4** below illustrates this point and shows that over a wide range of power demand, the average load on the gas engines will range from 78 per cent to 100 per cent, whereas the average load on the gas turbines will range from 50 per cent to 100 per cent. This will have an impact on the average fuel

<sup>28</sup> <http://www.karpowership.com/en/khan-class>

<sup>29</sup> <https://www.siemens-energy.com/global/en/offerings/power-generation/power-plants/seafloat.html>

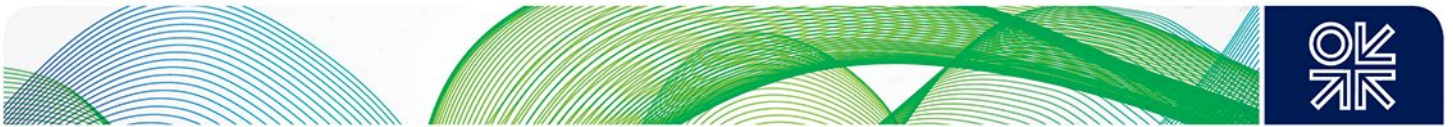

efficiency and will offset some of the advantages that the CC Gas Turbine has over the CC Gas Engine plant.

**Figure 4: Impact of power load on average generator loading**



Source: Author's analysis

### 6.7 Ambient air temperature

Changes in ambient air temperature will impact the power generators in different ways. An example of the generic relationship between power output from gas turbines and gas engines as a function of ambient temperature is shown in **Figure 5**.<sup>30</sup>

For projects in tropical climates, with high ambient temperatures, there can be power loss of up to 20 per cent depending on the type of gas turbine used. For gas engines, the power loss is much less pronounced, at less than 5 per cent.

On the FSRP this impact on gas turbine performance can be avoided by recovering the cold energy from the LNG regasification system, to chill the turbine inlet air to 15°C (see section 6.8 below). With this addition, there is little difference between the gas engine or gas turbine solution over a range of ambient temperatures.

<sup>30</sup> <https://www.araner.com/blog/aeroderivative-gas-turbines> - adapted by Author

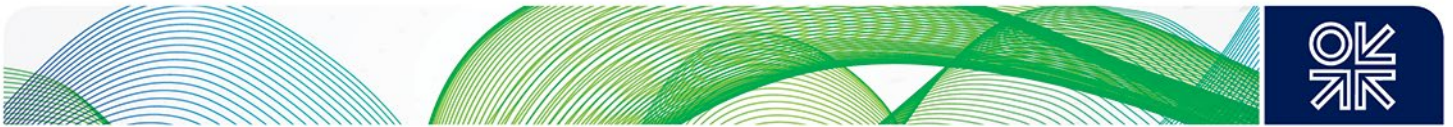

**Figure 5: Impact of ambient air temperature on power output**

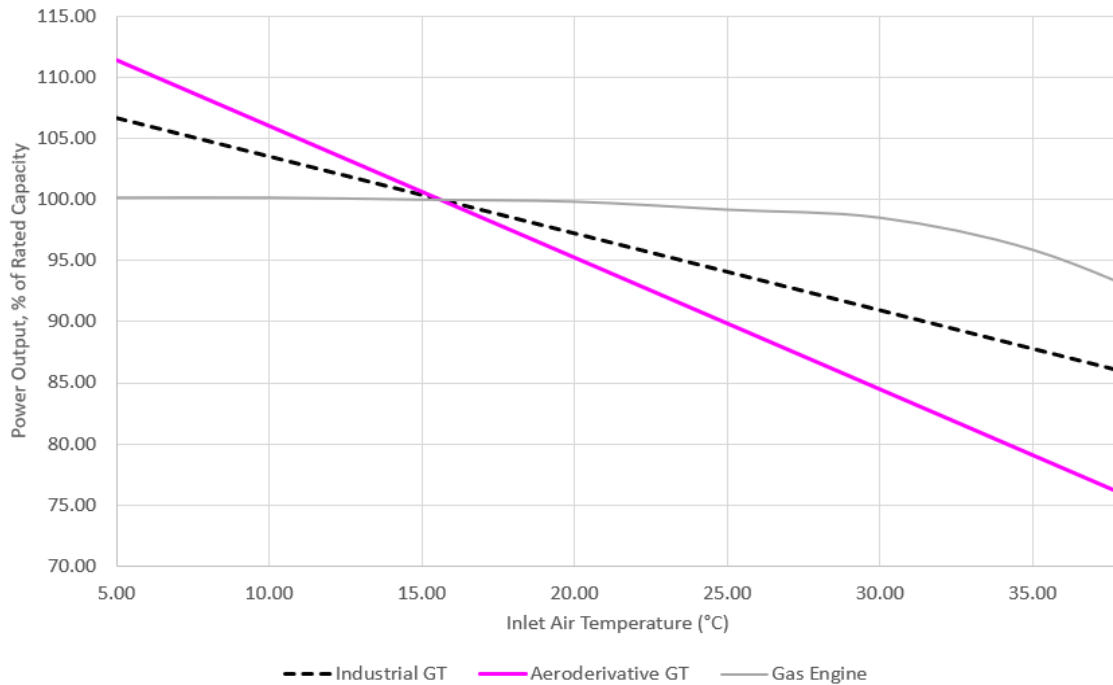

Source: Adapted by Author

### 6.8 Heat integration

In theory, an ‘LNG to Power’ project has two opportunities for heat integration, to improve performance and reduce environmental impact.

These are:

- a) Use of low-grade waste heat from a combined cycle steam turbine as a heat source for vaporisation and heating of the LNG stream. This will reduce the heat that is taken from the ambient seawater for open-loop LNG heating, or the fuel gas consumed for closed-loop heating.
- b) Use of cold energy from the LNG vaporisation to cool the combustion air into the gas turbines, and so reduce the cyclical impact of ambient air temperature variations on the gas turbine power output.

**Figure 6** shows how a traditional glycol/water IFV heating loop for LNG regasification can be modified to incorporate these two heat integration steps<sup>31</sup> and the modifications needed are shown in clouds.

This heat integration would be of little benefit for the gas-engine powered FPP vessel since:

- a) The gas engines are much less sensitive to ambient air variations than gas turbines.
- b) The amount of interconnecting piping needed on the jetty between the FPP and the FSRU makes this option less attractive than for the FSRP.

<sup>31</sup> Tarlowski, J. and Sheffield, J. (2012). ‘LNG IMPORT TERMINALS – RECENT DEVELOPMENTS’, M. W. Kellogg Ltd, United Kingdom

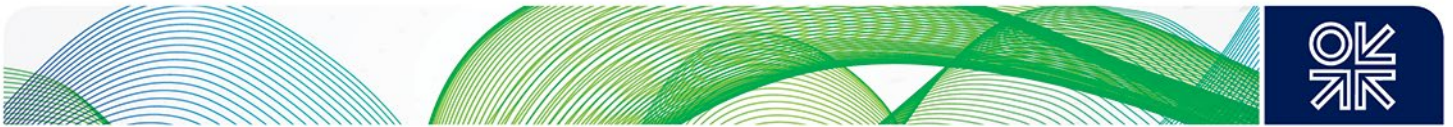

**Figure 6: FSRP glycol IFV heat integration schematic**

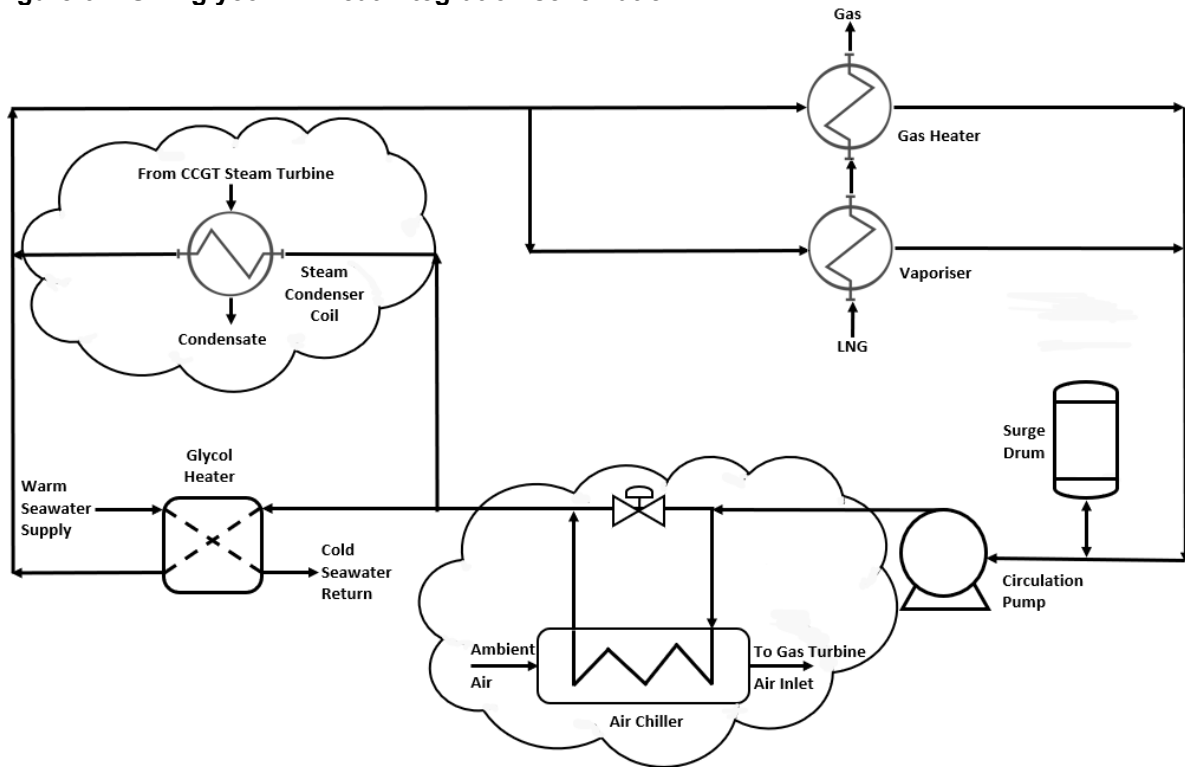

Source: Author's analysis

Consequently, this heat integration solution is valid mainly for the CC gas turbine-powered FSRP, where the additional equipment and piping can easily be accommodated on the vessel with no impact on the associated jetty. The benefits of this heat integration will be:

- a) Stable power output from the gas turbines, irrespective of the ambient temperature.
- b) Eliminate the seawater demand for heating the glycol loop (although there will still be a very large seawater demand for the FSRP steam condensers in CC mode).

## 6.9 Environmental emissions

The FSRU + FPP and the FSRP have different environmental impacts in two areas.

### a) Air emissions

The difference in CO<sub>2</sub> emissions between the two references cases is driven by the difference in fuel gas demand. Hence the comparison of CO<sub>2</sub> direct emissions from combustion is directly comparable with the fuel gas demand in section 6.0, where the FPP with gas engines has a fuel gas demand some nine per cent higher than the FPP.

Methane (CH<sub>4</sub>) slippage to the atmosphere must also be considered since methane has a greenhouse warming potential (GWP) some 84 times that of CO<sub>2</sub>.<sup>32</sup> Methane slip is the amount of methane that passes through the engine uncombusted into the exhaust gasses. For gas turbines, this is very low, sometimes quoted as 'unmeasurable', but the value of 0.06 gCH<sub>4</sub>/kWh quoted by the International

<sup>32</sup> <https://climatechangeconnection.org/emissions/co2-equivalents/>



Council on Clean Transportation (ICCT)<sup>33</sup> for a single cycle GT has been taken and adjusted to 0.04 gCH<sub>4</sub>/kWh for a combined cycle system.

For a gas engine, the methane slip is considerably higher. Typically, this is quoted at 5.5 gCH<sub>4</sub>/kWh at full load, but a lower level quoted by Wartsila of 2.8 gCH<sub>4</sub>/kWh<sup>34</sup> at full load has been applied.

Although the methane slip increases significantly at turndown, this has been ignored as evidence presented in 6.6 above shows that gas engines on the FPP would typically be running at high load.

For the reference case running at 100 per cent load, this would generate emissions as follows.

**Table 4: Comparison of CO<sub>2</sub> emissions**

Case	CO <sub>2</sub> from Combustion (T/D)	Methane Slip (T/D)	Methane Slips as Equivalent CO <sub>2</sub> (T/D)	Total CO <sub>2</sub> Equivalent Emissions (T/D)
CC Gas Turbines (FSRP)	3364	0.4	35.5	3400
CC Gas Engines (FPP)	3662	29.5	2482	6144

Source: Author's analysis

Methane slip from gas engines on the FPP, therefore, leads to the total CO<sub>2</sub> equivalent emissions for that option being some 80 per cent higher than that for the CC gas turbine plant on the FSRP.

Several technologies are being considered to reduce CH<sub>4</sub> slip, both within the engine and as exhaust gas after-treatment. Leading engine suppliers such as MAN and Wartsila have already made progress to reduce methane slip and claim to be aggressively pursuing solutions to reduce this further.<sup>35</sup> But the gap to gas turbine emissions remains large.

#### b) Water

The main requirement for seawater comes from the cooling load on the CC steam condenser and the heating load on the LNG vaporiser.<sup>36</sup> For the reference case this is as follows.

**Table 5: Comparison of heat loads**

	Condenser Cooling Load (MW)	LNG Heating Load (MW)	Total Load (MW)
CC Gas Turbines (FSRP)	612	-15.5	596.5
CC Gas Engines (FPP)	132	-17.4	114.6

Source: Author's analysis

The gas turbine option will therefore emit a heat load to the local sea around five times more than that of the FPP and FSRU. This is due to the waste heat recovery duty for the combined cycle being much

<sup>33</sup> [https://theicct.org/sites/default/files/publications/LNG%20as%20marine%20fuel%2C%20working%20paper-02\\_FINAL\\_20200416.pdf](https://theicct.org/sites/default/files/publications/LNG%20as%20marine%20fuel%2C%20working%20paper-02_FINAL_20200416.pdf)

<sup>34</sup> <https://www.wartsila.com/media/news/06-04-2020-cutting-greenhouse-gas-emissions-from-lng-engines>

<sup>35</sup> [https://man-es.com/docs/default-source/man-primiserv/sustainability/man\\_es\\_methane\\_slip\\_technical\\_paper.pdf?sfvrsn=fde9a343\\_4](https://man-es.com/docs/default-source/man-primiserv/sustainability/man_es_methane_slip_technical_paper.pdf?sfvrsn=fde9a343_4)

<sup>36</sup> Author's Research



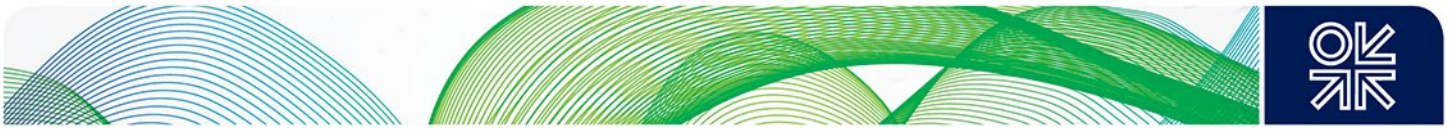

greater than that possible from the gas engines, resulting in higher overall efficiency and fewer emissions to the air, but partly offset by more heat rejection to the sea.

Technip<sup>37</sup> has proposed an alternative FSRP design that uses a closed-loop cooling tower system on the FSRP to eliminate heat rejection to seawater for environmentally sensitive cases. However, using cooling towers on a floater is novel and would require detailed analysis to confirm that the performance would be satisfactory on a moving vessel. If so, it could be an attractive, if costly, solution for environmentally sensitive locations. A smaller capacity FSRP using gas engines has the potential to use air cooling for the majority of the cooling loads, which is the case on the powership FPP solutions, so reducing seawater demand.

### 6.10 Regulatory (Permits)

The FSRP has the advantage that it requires only one berth, compared with two for the FSRU + FPP solution. This makes it easier to accommodate in a harbour, which should ease the permitting requirements.

The lower environmental footprint of the FSRP, as discussed in 6.9 above, could also make it attractive in some locations compared to the FSRU + FPP when gas engines are proposed.

### 6.11 Technical summary

The following table summarizes some of the main differences between using reciprocating gas engines and gas turbines.

**Table 6: Reciprocating gas engines – pros and cons**

Pros	<ul style="list-style-type: none"> <li>• Higher availability due to multiple engines.</li> <li>• Flat efficiency curve for part-load since engines can be stopped and started as the load varies.</li> <li>• Can be maintained by vessel crew – less need for expensive OEM engineers onboard.</li> <li>• Standardized machines.</li> <li>• Faster delivery time.</li> </ul>
Cons	<ul style="list-style-type: none"> <li>• Higher Capex.</li> <li>• Higher emissions due to methane slip. (May be reduced in future by ongoing developments).</li> <li>• Large space required, typically within the hull.</li> <li>• Many engines to operate in parallel and to maintain. Rolling maintenance plan needed.</li> <li>• The safety of gas-fuelled engines in an enclosed hull space must be managed.</li> <li>• Material handling facilities are needed for engine overhauls.</li> <li>• Low-frequency vibrations to be managed – isolators required.</li> </ul>

Source: Author's analysis

<sup>37</sup> See Gastech 2020, 'Integrated LNG to power: where the two worlds plug and play', Renaud Le Dévéhat, Director R&D, Technip France



**Table 7: Gas turbines – pros and cons**

Pros	<ul style="list-style-type: none"> <li>• Higher efficiency (at full load) in combined cycle mode.</li> <li>• Lower emissions (at full load) in combined cycle mode.</li> <li>• More compact, less space required.</li> <li>• Can be modularised and located on the main deck of the ship/barge.</li> <li>• No significant vibration issues to manage.</li> </ul>
Cons	<ul style="list-style-type: none"> <li>• A significant capacity impact from a single GT being stopped for maintenance. (N+1 strategy may be needed for some projects where high availability is required).</li> <li>• Engine exchange needed after (typically) 50,000 hours, with major OPEX impact.</li> <li>• Specialist OEM engineers needed onboard periodically, which can be costly.</li> <li>• Efficiency drops quickly for a part load. Large machines offer less flexibility to maintain high efficiency over variable load.</li> <li>• Higher impact of ambient air temperature (but can mitigate with inlet air chilling).</li> <li>• Material handling facilities are needed for engine exchange.</li> </ul>

Source: Author’s analysis

## 7. Commercial analysis for reference case project

To compare the commercial performance of the two reference case scenarios, the LCOE for each option has been calculated as follows. This is based on a simplified model which excludes any tax and subsidies.

### 7.1 Capital cost

The budget level CAPEX has been estimated for each scenario and converted into an equivalent charter rate over a 25-year term at a weighted average cost of capital (WACC) of seven per cent with a small residual value at the end of the term.

The FSRU and FPP are based on the conversion of existing hulls, following typical recent projects, whereas the FSRP is based on a new build hull. The CAPEX for the power plant includes a spare gas turbine core engine for the FSRP option, to ensure high availability.

### 7.2 Operating cost

For the OPEX, fixed and variable OPEX was considered, as follows.

Fixed OPEX is based on 2.5 per cent of CAPEX<sup>38</sup> per annum for the hull and marine systems. For the power generation, fixed OPEX is based on a factor of \$15/kW/y.<sup>39</sup>

Variable OPEX for the machinery maintenance and repair, based on running hours, is based on a factor of \$4.0/MWh for gas turbines and \$5.5/MWh for gas engines.<sup>40</sup>

<sup>38</sup> Songhurst B. (2017). ‘The Outlook for Floating Storage and Regasification Units’, NG123, OIES

<sup>39</sup> Tarlowski, J. and Sheffield, J. (2012). ‘LNG IMPORT TERMINALS – RECENT DEVELOPMENTS’, M. W. Kellogg Ltd, United Kingdom

<sup>40</sup> <https://www.wartsila.com/docs/default-source/smartpowergeneration/content-center/presentations/get-a-higher-return-on-investment-with-w%C3%A4rtsil%C3%A4-in-the-iso-ne-market.pdf>

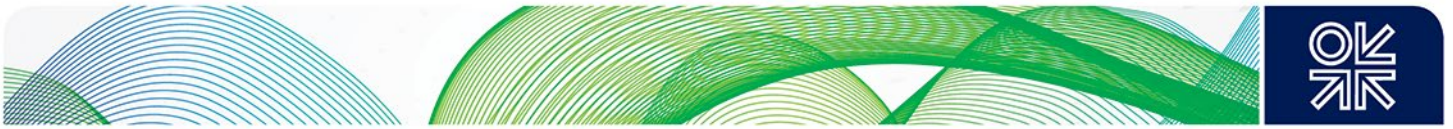

For fuel gas costs, an LNG cost of \$6.0/MMBtu for both options is assumed, ignoring any penalty for the smaller storage volume available on the FSRU.

### 7.3 Project schedule

Overall, the FSRU + FPP can typically be delivered on a much shorter schedule than the FSRP, hence improving the project net present value (NPV).

For the FSRP, a typical project schedule would be 24 to 30 months for a small-capacity unit, or 36 to 40 months for a large capacity unit, both being from contract award to arrival in the country, and assuming that the unit is custom-built for a specific project. So far, there seems to be little interest from companies to build FSRPs on speculation, as has been the case for FSRUs and FPPs, but this is expected to change once a prototype unit is in operation.

For the FSRU and FPP, both elements are routinely constructed on speculation and units are currently available on standby. Hence, the delivery and installation can take less than 12 months. The critical path, in this case, can be the time required for the permits, jetty and marine terminal construction, and the substation for connection to the HV power grid.

### 7.4 LCOE

Using the above data, a levelized cost of electricity (LCOE) for each scenario has been calculated, based on a simplified model which excludes tax and subsidies and assuming the LNG price shown above.

Three different average power loadings for the system – 100 per cent, 80 per cent and 60 per cent - have been used to investigate the impact of partial load on the LCOE. This is important for projects with a growing power demand profile over time. The results are shown in **Figure 7**.

**Figure 7: LCOE comparison between FSRP and FSRU+FPP solutions**

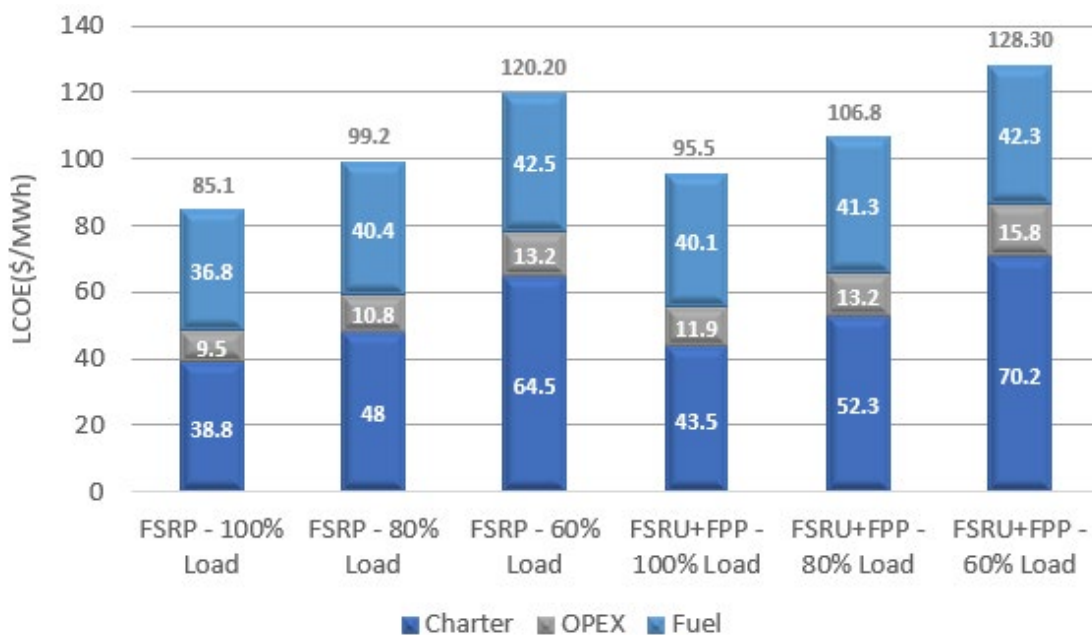

Source: Author's analysis

This analysis shows that the FSRU + FPP combination is around 10 per cent more costly than the FSRP option, for the scenario chosen and the assumptions made.



The LCOE for the FSRP option ranges from \$85 to \$120/MWh as the average loading drops from 100 per cent to 60 per cent. This is driven mainly by the charter rate, which is fixed, irrespective of throughput.

The FSRU + FPP shows the same trend, with the LCOE increasing from \$96 to \$128/MWh as the loading drops from 100 per cent to 60 per cent.

These figures compare to an LCOE range given by Lazard<sup>41</sup> for combined cycle power generation of \$44 to \$73/MWh, based on an assumed fuel gas price of \$3.45/MMBtu. The equivalent figure for the FSRP at 100 per cent load with this same LNG price assumed would be \$69.5/MWh, so falling within the Lazard range. The LCOE range given by Lazard for coal-fired power plants is \$65 to \$159/MWh, with the upper end including CCS facilities.

## 8. Conclusions

Onshore regasification terminals are being replaced by FSRUs at an increasing rate. Around 30 per cent of new terminals are now being developed with FSRUs, mainly the smaller capacity units up to five mtpa. For these projects, an FSRU can often be developed faster, at a lower cost, and with lower capital intensity using a leased vessel.

The same trend is emerging for gas-fired power generation plants, where the same benefits are now possible. Leased power barges and power ships are now available on the market up to 500 MW, and in the future, this could grow to 1 GW capacity.

The leading technology for floating 'LNG to Power' is the FSRU + FPP. Around 70 FPPs are currently deployed worldwide, and whilst most of these were originally built as liquid-fuelled, a growing number are being converted to gas fuel. For leased units, the market is dominated by Karpowership, whose fleet of 19 operating vessels has a capacity of around 2.8 GW and several more units are under construction. A new JV with MOL will supply dedicated FRSUs paired with their FPPs.

However, this concept has the drawback that it requires two vessels to be accommodated at the site, so permitting can be complicated. Moreover, the use of reciprocating engines for powerships can bring environmental concerns from methane slip.

The alternative concept of the FSRP has the advantage of integrating the FSRU and FPP into a single vessel and using high efficiency combined cycle gas turbines with emission levels around half of the reciprocating engines. Whilst this concept has approval in principle (AIP) from various Classification Societies, none has yet been built.

Comparing LCOE for these two concepts, the FSRP should be able to deliver power at around 10 per cent lower cost than the FSRU + FPP. That, coupled with the emissions and permitting benefits, should make it an attractive option.

However, so far, FSRPs are only available for purchase, and are not being built on speculation and offered for lease, so they do not bring the advantage of speed. Typical project schedules for FSRP are currently around two years longer than the equivalent FSRU + FPP schedule.

The pros and cons of both options are summarized as follows.

---

<sup>41</sup> <https://www.lazard.com/media/451419/lazards-levelized-cost-of-energy-version-140.pdf>



**Table 8: FSRU + FPP – pros and cons**

Pros	<ul style="list-style-type: none"> <li>• Shorter schedule – both elements are standardized and readily available in the market.</li> <li>• Ability to charter the FSRU, the FPP, or both from several parties.</li> <li>• Both the FSRU and the FPP are fully mature and proven in service for many years.</li> <li>• Inherent safety by distance - separation of the FSRU and FPP.</li> <li>• LNG and power industries are quite different and operate with different rules and standards. This model retains this segregation and avoids integration issues.</li> <li>• Easier to relocate, since FSRU and FPP can be adjusted separately to meet the next project requirements.</li> <li>• One FSRU can supply multiple FPPs.</li> </ul>
Cons	<ul style="list-style-type: none"> <li>• The vessels will be generic designs built on speculation, so will not be optimized for any specific project.</li> <li>• Two hulls to operate and maintain.</li> <li>• Two mooring systems required.</li> <li>• Two vessels' berths required.</li> <li>• Two separate crews needed for the two vessels.</li> <li>• Interconnection piping (and cabling) needed between the 2 vessels, with safety risks to be managed.</li> <li>• Difficult to achieve heat integration between the FPP and FSRU.</li> <li>• The safety of gas-fuelled engines in an enclosed hull space must be managed.</li> <li>• Capacity limited to around 500 MW per FPP.</li> </ul>

Source: Author's analysis

**Table 9: FSRP – pros and cons**

Pros	<ul style="list-style-type: none"> <li>• Only one hull, one mooring system, and one berth required.</li> <li>• Lower environmental impact possible from an integrated design.</li> <li>• No interconnecting piping or cabling needed.</li> <li>• Feasible to achieve heat integration and cold energy recovery to maximize performance and minimize emissions.</li> <li>• The vessel can be custom-built for a project and optimized to client requirements, so should be lower CAPEX.</li> <li>• One integrated crew, with synergy potential, so OPEX saving.</li> <li>• Capacity up to 1GW per FRSP.</li> <li>• Several designs have been granted AIP by various classification societies.</li> </ul>
Cons	<ul style="list-style-type: none"> <li>• Unproven. No such vessel has yet been built, so the first project will be a prototype.</li> <li>• A limited number of credible parties available to build, charter and operate such a unit.</li> <li>• Long schedule since these vessels are likely to be built for specific projects and not on speculation.</li> <li>• Safety impact of gas turbines close to regas skid to be managed – a blast wall may be needed.</li> <li>• Safety impact of gas turbines close to HV power export equipment to be managed.</li> </ul>

Source: Author's analysis

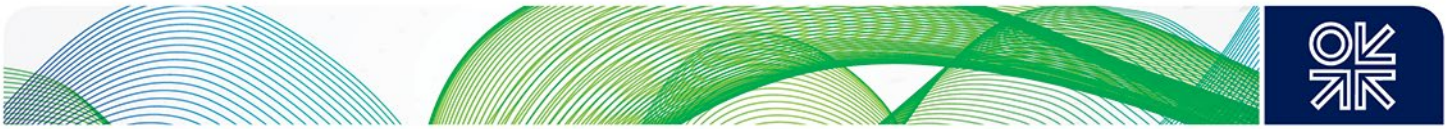

Overall, it is expected that the first FSRP project will be sanctioned soon, and if these do become available as leased units on short delivery in the future, they could displace the FSRU + FPP solution for larger projects. However, although the FSRP offers a lower LCOE, environmental factors will also play an important role. Where methane slip is a concern the FSRP or a GT power barge may be favoured, but in a closed harbour, the lower seawater demand from a powership or gas engine power barge may be more attractive.

So, whilst a growth in floating 'LNG to Power' projects is expected in future, several options are likely to co-exist allowing project-specific optimization.

In terms of overall demand, anticipated growth in the floating 'LNG to Power' market is expected to be around one to two GW per year of installed capacity over the next five years, with these new projects mainly located in South America, West Africa and South-East Asia. This would add new LNG demand each year of around one to two mtpa.

## Glossary

Acronym	Meaning
AAV	Ambient Air Vaporiser
AIP	Approval in Principle
BOG	Boil Off Gas
CAPEX	Capital Expenditure
CC	Combined (Steam) Cycle
CCS	Carbon Capture and Storage
EPCI	Engineering, Procurement, Construction and Installation
FID	Final Investment Decision
FLNG	Floating LNG Production, Storage and Offloading vessel.
FSU	Floating Storage Unit
FSRU	Floating Storage & Regassification Unit
FSRP	Integrated Floating Storage, Regassification and Power Generation Unit
FPSO	Floating Production, Storage and Offloading vessel (for oil and gas production)
FPP	Floating Power Plant (Barge or Ship based)
FOM	Fixed Operating & Maintenance Costs
GT	Gas Turbine
HFO	Heavy Fuel Oil
IFV	Intermediate Fluid Vaporiser
IHI	IHI Corporation, Japan
LCOE	Levelised Cost of Electricity
LNG	Liquefied Natural Gas
LNGC	LNG Carrier
MDO	Marine Diesel Oil
MOL	Mitsui O.S.K. Lines
OEM	Original Equipment Manufacturer
OPEX	Operating Expenditure
ORV	Open Rack Vaporiser
PPA	Power Purchase Agreement

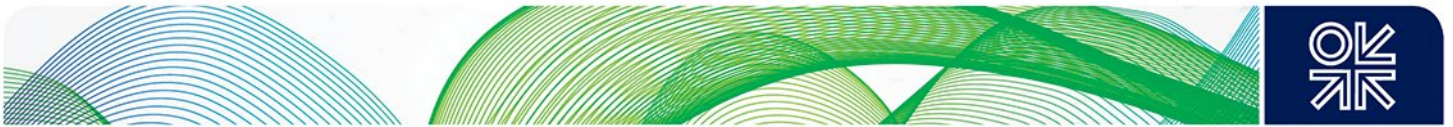

RE	Reciprocating Engine
SC	Simple Cycle
SCV	Submerged Combustion Vaporiser
SPB	IMO Type B tanks, IHI SPB Version
STV	Shell and Tube Vaporiser
TRL	Technology Readiness Level
VOM	Variable Operating & Maintenance Costs
WACC	Weighted Average Cost of Capital