

Schneeweiss, Hans; Shalabh

Working Paper

On the estimation of the linear relation when the error variances are known

Discussion Paper, No. 493

Provided in Cooperation with:

Collaborative Research Center (SFB) 386: Statistical Analysis of discrete structures - Applications in Biometrics and Econometrics, University of Munich (LMU)

Suggested Citation: Schneeweiss, Hans; Shalabh (2006) : On the estimation of the linear relation when the error variances are known, Discussion Paper, No. 493, Ludwig-Maximilians-Universität München, Sonderforschungsbereich 386 - Statistische Analyse diskreter Strukturen, München, <https://doi.org/10.5282/ubm/epub.1861>

This Version is available at:

<https://hdl.handle.net/10419/31098>

Standard-Nutzungsbedingungen:

Die Dokumente auf EconStor dürfen zu eigenen wissenschaftlichen Zwecken und zum Privatgebrauch gespeichert und kopiert werden.

Sie dürfen die Dokumente nicht für öffentliche oder kommerzielle Zwecke vervielfältigen, öffentlich ausstellen, öffentlich zugänglich machen, vertreiben oder anderweitig nutzen.

Sofern die Verfasser die Dokumente unter Open-Content-Lizenzen (insbesondere CC-Lizenzen) zur Verfügung gestellt haben sollten, gelten abweichend von diesen Nutzungsbedingungen die in der dort genannten Lizenz gewährten Nutzungsrechte.

Terms of use:

Documents in EconStor may be saved and copied for your personal and scholarly purposes.

You are not to copy documents for public or commercial purposes, to exhibit the documents publicly, to make them publicly available on the internet, or to distribute or otherwise use the documents in public.

If the documents have been made available under an Open Content Licence (especially Creative Commons Licences), you may exercise further usage rights as specified in the indicated licence.

On the Estimation of the Linear Relation when the Error Variances are known

H. Schneeweiss

Department of Statistics

University of Munich

80799 Munich (Germany)

E-mail: Hans.Schneeweiss@stat.uni-muenchen.de

Shalabh

Department of Mathematics and Statistics

Indian Institute of Technology

Kanpur-208016 (India)

E-mail: shalab@iitk.ac.in; shalabh1@yahoo.com

Discussion Paper 493 SFB386

University of Munich, Munich

Abstract

The present article considers the problem of consistent estimation in measurement error models. A linear relation with not necessarily normally distributed measurement errors is considered. Three possible estimators which are constructed as different combinations of the estimators arising from direct and inverse regression are considered. The efficiency properties of these three estimators are derived and analyzed. The effect of non-normally distributed measurement errors is analyzed. A Monte-Carlo experiment is conducted to study the performance of these estimators in finite samples and the effect of a non-normal distribution of the measurement errors.

1 Introduction:

In a linear measurement error model, the parameters can be estimated consistently only when some additional information besides the data set is available. There are various ways such additional information can be employed; e.g.; Cheng and Van Ness (1999) and Fuller (1987). Among them, application of the knowledge of all or one of the measurement error variances is the most prominent approach.

There are three basic consistent estimators of the slope parameter of the linear model depending on what knowledge is used. If only one of the two error variances is known and used, estimators can be constructed by adjusting either the direct (or ordinary) least squares (LS) or the inverse least squares estimator for measurement errors. A third, most prominent, estimator is orthogonal (or total) least squares (TLS), which relies on the knowledge of the ratio of the error variances. For normally distributed measurement errors, this latter estimator is the maximum likelihood estimator. However the former two can be combined in various ways to construct new estimators that can compete with the TLS estimator, in particular in small samples and when the measurement errors are non-normal.

We have considered three such combinations of the direct and inverse adjusted LS estimators. They are modelled after analogous combinations found in the literature, where, however, they have been constructed from non-adjusted direct and inverse LS estimators. Sokal and Rohlf (1981) considered the geometric mean of these two estimators (which they call the technique of reduced major axis) and Aaronson et al. (1986) work with the arithmetic mean. In addition, the slope parameter may be estimated by the slope of the line that bisects the angle between the direct and inverse regression lines; see, e.g., Pierce and Tully (1988). While all these estimators are not consistent (although they possibly reduce the bias inherent in their constituent direct and inverse LS estimators), the present paper constructs consistent estimators by using error adjusted direct and inverse LS rather than non-adjusted direct and inverse LS estimators. A

simple question then arises: which out of these suggested estimators is better under what conditions. This question has been partly dealt with in Dorff and Gurland (1969), but for a model with replicated observations and unknown error variances.

It seems plausible that the reliability ratios associated with study and explanatory variables are often easily available or can be well estimated in measurement error models, see, Gleser (1992, 1993) for more details on this aspect. An attempt is made in this paper to express the efficiency properties of all the estimators under consideration as a function of reliability ratios associated with study and explanatory variables only. This helps in obtaining conditions for the superiority of one estimator over the other in terms of reliability ratios only.

Further, most of the literature associated with measurement error models generally assumes the normal distribution for the measurement errors. In practice, such an assumption may not always hold true. The distribution of measurement errors essentially depends on the nature of experiment. The specification of normality may thus sometimes lead to invalid and erroneous statistical consequences. The effect of departure from normality is another aspect of the study which is attempted in this paper.

The finite sample properties of the proposed estimators under different types of distributions of measurement errors are studied through a Monte-Carlo experiment.

The plan of our presentation is as follows. In Section 2, we describe a linear model with measurement errors and present the estimators of the slope parameter when the error variances are known. Section 3 analyzes the asymptotic properties of the estimators when the underlying error distributions are not necessarily normal. The details of the Monte-Carlo experiment and its outcomes are reported in Section 4. Some concluding remarks are offered in Section 5. Lastly, the Appendix outlines the derivation of the main results.

2 Model Specification And the Estimators :

Consider a linear measurement error model in which the variables are related by the linear relation

$$Y_j = \alpha + \beta X_j \quad (j = 1, 2, \dots, n) \quad (2.1)$$

where Y_j and X_j denote the true but unobserved values of the variables, α is the unknown intercept term and β is the unknown slope parameter.

The observed values y_j and x_j are expressible as

$$y_j = Y_j + u_j \quad (2.2)$$

$$x_j = X_j + v_j \quad (2.3)$$

where u_j and v_j denote the associated measurement errors.

We assume that X_1, X_2, \dots, X_n are independently distributed random variables such that $plim_{n \rightarrow \infty} \bar{X} =: \mu_X$ and $plim_{n \rightarrow \infty} \frac{1}{n} \sum (X_j - \bar{X})^2 =: \sigma_X^2$ exist and $\sigma_X^2 > 0$. The measurement errors u_1, u_2, \dots, u_n are assumed to be independently and identically distributed with mean 0, variance σ_u^2 third moment $\gamma_{1u}\sigma_u^3$ and fourth moment $(\gamma_{2u} + 3)\sigma_u^4$. The quantities $\gamma_{1.}$ and $\gamma_{2.}$ represent the measures of skewness and kurtosis of the respective distributions denoted in subscripts. Similarly, the errors v_1, v_2, \dots, v_n are assumed to be independently and identically distributed with mean 0, variance σ_v^2 third moment $\gamma_{1v}\sigma_v^3$ and fourth moment $(\gamma_{2v} + 3)\sigma_v^4$. Further, the random variables (X_j, u_j, v_j) are assumed to be jointly independent.

It may be noted that this model comprises the so-called ultrastructural model, see Dolby (1976), which in turn contains the structural and the functional model as special cases. In the structural model, the X_j 's are i.i.d. random variables with mean μ_X and variance σ_X^2 . In the functional model, the X_j are unknown constants with the property that $lim_{n \rightarrow \infty} \bar{X} =: \mu_X$ and $\frac{1}{n} \sum (X_j - \bar{X})^2 =: \sigma_X^2$ exist.

Consistent estimation of the parameters α and β in the relationship (2.1) with the help of given data $(x_j, y_j), j = 1, \dots, n$, is possible only when some additional

information is available.

This additional information, let us suppose, specifies the error variances σ_u^2 and σ_v^2 . We can then estimate the slope parameter β consistently by the method of moments. This provides the following estimators of β .

$$b_d = \frac{s_{xy}}{s_{xx} - \sigma_v^2} ; s_{xx} > \sigma_v^2 \quad (2.4)$$

$$b_i = \frac{s_{yy} - \sigma_u^2}{s_{xy}} ; s_{yy} > \sigma_u^2 \quad (2.5)$$

where

$$\begin{aligned} s_{xx} &= \frac{1}{n} \sum (x_j - \bar{x})^2 , & \bar{x} &= \frac{1}{n} \sum x_j ; \\ s_{yy} &= \frac{1}{n} \sum (y_j - \bar{y})^2 , & \bar{y} &= \frac{1}{n} \sum y_j ; \\ s_{xy} &= \frac{1}{n} \sum (x_j - \bar{x})(y_j - \bar{y}). \end{aligned}$$

When $s_{xx} < \sigma_v^2$ in b_d or $s_{yy} < \sigma_u^2$ in b_i , then one possible solution is to disregard the whole sample because the measurement errors are too high to spoil the whole data set. Another alternative is to use the small sample modifications in the estimators as suggested in Fuller (1987). Further discussion on this issue is out of the purview of this paper.

The estimator b_d can be regarded as the direct OLS estimator of the slope parameter in the regression of y_j on x_j^* instead of x_j ; see, e.g., Srivastava and Shalabh (1997a) and Shalabh (1998), where

$$x_j^* = \bar{x} + \left(1 - \frac{\sigma_v^2}{s_{xx}}\right) (x_j - \bar{x}). \quad (2.6)$$

Similarly, if we write

$$y_j^* = \bar{y} + \left(1 - \frac{\sigma_u^2}{s_{yy}}\right) (y_j - \bar{y}), \quad (2.7)$$

the inverse estimator b_i essentially arises from the regression of x_j on y_j^* instead of y_j .

It may be observed that the estimators b_d and b_i utilize the knowledge of only one error variance at a time. An estimator using the knowledge of both the error variances is given by

$$b_p = t_p + \left(t_p^2 + \frac{\sigma_u^2}{\sigma_v^2} \right)^{\frac{1}{2}} ; \quad t_p = \frac{1}{2s_{xy}} \left(s_{yy} - \frac{\sigma_u^2}{\sigma_v^2} s_{xx} \right) ; \quad s_{xy} \neq 0 \quad (2.8)$$

which is obtained by minimizing the sum of squares of the perpendicular distance from the data points to the line in a scatter diagram, (i.e., orthogonal regression) after the data x_j and y_j have been transformed to x_j/σ_v and y_j/σ_u , respectively.

In the technique of “reduced major axis”, the slope parameter β is estimated by the geometric mean of the estimators arising from direct and inverse regression estimators as

$$b_g = \text{sign}(s_{xy}) |b_d b_i|^{\frac{1}{2}}, \quad (2.9)$$

where $\text{sign}(s_{xy})$ is the sign of s_{xy} which can be either positive or negative.

Similarly, we may estimate β by

$$b_m = \frac{1}{2} (b_d + b_i), \quad (2.10)$$

which is the arithmetic mean of estimators b_d and b_i .

Another interesting estimator of β is

$$b_b = t_b + (t_b^2 + 1)^{\frac{1}{2}} ; \quad t_b = \frac{b_d b_i - 1}{b_d + b_i}, \quad (2.11)$$

which is the slope of the line that bisects the angle between the two regression lines specified by b_d and b_i .

It may be observed that all six estimators of β can be seen to have arisen from the method of moments.

3 Asymptotic Properties:

The asymptotic variances of the estimator b_d , b_i and b_p under an ultrastructural model and when errors are not necessarily normally distributed have been studied

by Shalabh, Gleser and Rosen (2004), see also, Srivastava and Shalabh (1997b), Schneeweiss (1976) and Fuller (1987). For the sake of convenience to the reader, we restate these results. In addition, we give an expression for the asymptotic covariance of b_d and b_i , which will be used in the derivation of the asymptotic variances of b_g , b_m and b_b .

Proposition 1: The estimators b_d and b_i are asymptotically jointly normally distributed as

$$\sqrt{n} \begin{pmatrix} b_d - \beta \\ b_i - \beta \end{pmatrix} \rightarrow N(0, \Sigma_b) \quad \text{where} \quad \Sigma_b = \begin{pmatrix} \sigma_{dd} & \sigma_{di} \\ \sigma_{di} & \sigma_{ii} \end{pmatrix}$$

with

$$\sigma_{dd} = \beta^2 \left(\frac{1 - \lambda_x}{\lambda_x^2} \right) [\lambda_x + q + (1 - \lambda_x)(2 + \gamma_{2v})] \quad (3.1)$$

$$\sigma_{ii} = \beta^2 \left(\frac{1 - \lambda_x}{\lambda_x^2} \right) [\lambda_x + q + q^2(1 - \lambda_x)(2 + \gamma_{2u})] \quad (3.2)$$

$$\sigma_{di} = \beta^2 \left(\frac{1 - \lambda_x}{\lambda_x^2} \right) [\lambda_x + q(2\lambda_x - 1)] \quad (3.3)$$

where

$$\begin{aligned} \lambda_x &= \frac{\sigma_X^2}{\sigma_x^2} = \frac{\sigma_X^2}{\sigma_X^2 + \sigma_v^2} \\ \lambda_y &= \frac{\beta^2 \sigma_X^2}{\beta^2 \sigma_X^2 + \sigma_u^2} \\ q &= \frac{\lambda_x(1 - \lambda_y)}{\lambda_y(1 - \lambda_x)} \end{aligned}$$

The proof of this Proposition is stated in the Appendix.

Notice that λ_x and λ_y are the reliability ratios of the explanatory and study variables in the model. Obviously, $0 < \lambda_x \leq 1$, $0 \leq \lambda_y \leq 1$, and $q \geq 0$.

Proposition 2: The estimator b_p is asymptotically normally distributed as

$$\sqrt{n}(b_p - \beta) \rightarrow N(0, \sigma_{pp})$$

with asymptotic variance

$$\sigma_{pp} = \beta^2 \left(\frac{1 - \lambda_x}{\lambda_x^2} \right) \left[\lambda_x + q + \frac{q^2(1 - \lambda_x)}{(q + 1)^2} (\gamma_{2u} + \gamma_{2v}) \right]. \quad (3.4)$$

The proof of the Proposition 2 follows from Shalabh et al. (2004).

Proposition 3: Let $\hat{\beta}_1$ and $\hat{\beta}_2$ be two consistent, asymptotically jointly normal estimators of β . Any estimator $\hat{\beta}$ of β which is a differentiable and symmetric function $g(\hat{\beta}_1, \hat{\beta}_2)$ of $\hat{\beta}_1$ and $\hat{\beta}_2$ such that $\beta = g(\beta, \beta)$ is consistent and asymptotically normally distributed with an asymptotic variance given by

$$\sigma_{\hat{\beta}}^2 = \frac{1}{4} (\sigma_{11} + 2\sigma_{12} + \sigma_{22}),$$

where $\Sigma = (\sigma_{ij})$, $i, j = 1, 2$, is the asymptotic covariance matrix of $(\hat{\beta}_1, \hat{\beta}_2)$.

The proof of this Proposition is stated in the Appendix.

Thus, using Propositions 1 and 3, it is seen that the estimators b_g , b_m , and b_b are all consistent and asymptotically normal with the same asymptotic variance given by

$$\beta^2 \frac{(1 - \lambda_x)\delta}{4\lambda_x^2} \quad (3.5)$$

where

$$\delta = 2[q^2(1 - \lambda_x) + 1 + \lambda_x + 2q\lambda_x] + (1 - \lambda_x)(\gamma_{2v} + q^2\gamma_{2u}). \quad (3.6)$$

It is interesting to observe from (3.5) and (3.6) that the skewness of the distributions of measurement errors has no influence on the asymptotic variances of the estimators. It is only the kurtosis that shows its effect. Further, it is seen that the asymptotic variance for each estimator under normality of errors could be quite different when the distributions depart from normality.

It is interesting to note that the estimators b_g , b_m and b_b are equally efficient. Comparing the asymptotic variances, we find that the estimator b_p is more efficient than b_g , b_m or b_b if, and only if,

$$2(q^2 - 1)^2 \geq (q - 1)[(1 + 3q)\gamma_{2v} - q^2(q + 3)\gamma_{2u}] \quad (3.7)$$

Condition (3.7) is clearly satisfied when both measurement errors have mesokurtic (e.g., normal) distributions. The condition also holds true when $q > 1$ and $\gamma_{2u} \geq 0$ and $\gamma_{2v} < 0$.

When either of the measurement errors has a distribution with non-zero coefficient of kurtosis, the inequality (3.7) may not always hold true. So the estimator b_p may not necessarily have minimum variance under non-normal distributions of measurement errors.

Next, we compare the asymptotic variances of b_g , b_m or b_b with b_d and b_i . We find that b_g , b_m or b_b are better than b_d if, and only if,

$$3\gamma_{2v} - q^2\gamma_{2u} > 2(q-3)(q+1) \quad (3.8)$$

Condition (3.8) is always satisfied for mesokurtic (e.g., normal) distributions of u and v when $q < 3$.

Similarly, b_g , b_m or b_b are better than b_i if, and only if,

$$\gamma_{2v} - 3q^2\gamma_{2u} < 2(3q-1)(q+1). \quad (3.9)$$

Condition (3.9) is always satisfied for mesokurtic (e.g., normal) distributions of u and v when $q > \frac{1}{3}$.

From (3.8) and (3.9), it is clear that the use of two types of additional information to obtain a consistent estimator is not always a good idea, at least asymptotically. Rather, it depends on the values of reliability ratios associated with dependent and independent variables as well as on the degree of peakedness of the distributions of measurement errors to decide which of the information can give better asymptotic results.

4 Monte Carlo Simulation:

The asymptotic theory developed in the previous section gives an idea about the behaviour of estimators for large samples only. We conducted a Monte-Carlo sim-

ulation to study the behaviour of the estimators in finite samples. The following probability distributions of measurement errors are considered to have an idea of the effect of departure from the normal distribution on the efficiency properties of the estimators:

1. normal distribution,
2. t -distribution with 6 degrees of freedom,
3. beta distribution $Beta(4, 2)$, and
4. Weibull distribution with shape parameter 1 and scale parameter 2.

Two data sets of sample sizes $n = 40$ (treated as small sample) and $n = 400$ (treated as large sample) are considered, for which $\sigma_X^2 = 0.08$. The empirical bias (EB) and empirical mean squared error (EMSE) of the estimators $b_d, b_i, b_p, b_g, b_m,$ and b_b are computed based on 10000 replications for both the sample sizes and for different combinations of $\lambda_x = 0.1, 0.3, 0.5, 0.7, 0.9$ and $\lambda_y = 0.1, 0.3, 0.5, 0.7, 0.9$ under different distributions of measurement errors. The values of EB and EMSE of these estimators are presented in Tables 1 to 8 and are plotted against λ_x and λ_y in 3-dimensional surface plots in Fig. 1 to 8. It should be noted that the figures employ different scalings on the Z -axis. So the behaviour and dependency of EB and EMSE with respect to λ_x and λ_y is more clearly visible from the values compiled in the Tables 1 to 8. On the other hand, the shape of the functions $EB(\lambda_x, \lambda_y)$ and $EMSE(\lambda_x, \lambda_y)$ comes out more clearly in the figures.

The following notations are used in figures 1 to 8: $\lambda_x = lx, \lambda_y = ly, b_d = bd, b_i = bi, b_p = bp, b_g = bg, b_m = bm$ and $b_b = bb$.

Now we analyze the behaviour of EB and EMSE of different estimators through Fig. 1 to 8 under a given distribution of measurement errors. We are mainly concerned in the pattern of the surfaces rather than the magnitude of values.

First we compare the properties of the various surface plots of EB in Fig. 1 to 4 under small and large samples. Generally speaking, the small sample plots

($n = 40$) show much more variability than the large sample plots ($n = 400$). This is particularly true for small λ_x and λ_y . This variability reflects the extremely high variances of the estimates for small λ_x and λ_y (see below). Nevertheless, the bias is statistically significant in most cases.

In the case of normal measurement errors (Fig. 1), the surface plots of EB of b_d and b_i are similar under small and large samples, whereas the surface plots of b_p , b_g , b_m , and b_b differ between small and large samples. The EB of b_g changes sign when going from small to large samples and when λ_x and λ_y are small. Under the t distribution of measurement errors, (see Fig. 2), only the EBs of b_g and b_b are similar in their behaviour under small and large samples. The sign of EB of b_d is partly positive and partly negative in small samples depending on the values of λ_x and λ_y , whereas it is always negative in large samples. Under the beta distribution of measurement errors, (see Fig.3), only b_d has similar surface plots in small and large samples, while the rest shows differences. In small samples, b_i and b_g are negatively biased either for very low or very high values of λ_x and λ_y , whereas they are always positively biased in large samples. The EB of b_d and b_g have similar surface plots in small and large samples under Weibull distributed measurement errors (see Fig. 4). Only b_d is negatively biased, whereas the sign of the bias of the other estimators depends on the values of λ_x and λ_y .

Next, we analyze the dependence of the EMSE of the estimators from Fig. 5 to 8 on the sample size. In general, all EMSE values become small when λ_x and λ_y are large, whereas for small λ_x and/or λ_y , the EMSE often becomes extremely large. Under normally distributed measurement errors (see Fig. 5), the surface plots of b_i are quite similar for small and large samples, whereas those for the other estimators show marked differences in small and large samples especially if λ_x and/or λ_y are small. Under the t distribution of measurement errors (see, Fig. 6), no similarity can be seen between small and large samples. Only the surface plots of EMSEs of b_d and b_i under the beta distributed measurement

errors (see Fig. 7) are similar between small and large samples. More variation in the corresponding EMSEs of all estimators under small and large samples is seen in Weibull distributed measurement errors (see Fig. 8). None of the estimators have similar surface plots in small and large samples.

Now we compare the different surface plots of EB (Fig. 2 to 4) with those of the normal distribution (Fig. 1) thereby studying the effect of deviations from normality on the EB of the various estimators. Comparing the surface plots of EB of different corresponding estimators under normal and t -distributed measurement errors (Fig.1 and 2), we find that all are different except b_p . The difference is more pronounced in the EBs of corresponding estimators in small samples than in large samples. Such a difference may be seen as the contribution of peakedness of the distribution on EB. The surface patterns of all estimators under normal and beta distributions of measurement errors are remarkably similar (Fig. 1 and 3). The reason being that the coefficients of skewness and kurtosis of the distributions under consideration have very small values. The surface plots of each of the corresponding estimators under normal and Weibull distributions of measurement errors (Fig. 1 and 4) are different except for b_p in large samples. This clearly indicates that the departure from normality do affect the EB of these estimators.

Now we compare the surface plots of the empirical mean squared error (EMSE) of different estimators under different distributions of measurement errors (Fig. 6 to 8) to those under normally distributed measurement errors (Fig. 5). Firstly, we compare the surface plots under normal and t -distributions of measurement errors (Fig. 5 and 6). We observe that the surface plots of EMSEs of only b_i and b_p are similar in large samples only and all others are different. This indicates that the kurtosis of the distribution of measurement errors affects the EMSEs of the estimators significantly. Comparison of the surface plots of EMSEs under beta with those under normal distributions of measurement errors (Fig. 8 and 9) reveals that most of the surface plots of estimators are similar because of low

values of coefficient of skewness and kurtosis of the beta distribution (Fig. 5 and 7). Similarly, comparing the surface plots of EMSEs under Weibull distribution and normal distribution reveals that only b_i , b_d and b_m have similar behaviour with respect to λ_x and λ_y in small samples, but the corresponding large sample plots are different. It is worth noting that b_p has similar whereas b_m has different surface plots in large samples in respective distributions. We note that the asymptotic theory indicates that b_g , b_m and b_b should have similar surface plots. So it is clear that the departure from normality of the distribution of measurement errors play an important role in determining the EMSE of the estimators. However, this is only true for small λ_x and λ_y .

Now we look at the behaviour of EB and EMSE with respect to λ_x and λ_y under different distributions from Tables 1 to 8. It is observed that the values of EB and EMSE under $n = 400$ are closer to the true values of the parameters than under $n = 40$ for all distributions, which confirms the consistency of the estimators.

We observe that under the normal distribution of measurement errors (Table 1 and 2) that as either of the values of λ_x or λ_y increases, the EB and EMSE of all the estimators decreases. But the magnitude of EB and EMSE of every estimator is different. The EB of b_g has smallest magnitude among other estimators in small samples when λ_x and λ_y are low, say, less than 0.3, otherwise b_p has lowest magnitude of EB. An interesting finding is that when λ_x and λ_y are very low, the performance of b_b is best among other estimators with respect to EMSE. This dominance is stronger in small samples over a wider range of values of λ_x and λ_y . In fact, both b_g and b_b have smaller variability than b_p when λ_x and λ_y are low. The estimator b_p outperforms other estimators only when λ_x and λ_y are not very low. We know from large sample theory that b_g , b_b and b_m have the same asymptotic variance. We may therefore expect a similar variability for these estimators in large samples. This however holds true only when λ_x and λ_y are

high. In small samples and with lower values of λ_x and λ_y , this is no more true. The performance of b_p is adversely affected when λ_y is low in comparison to when λ_x is low. For higher values of λ_x and λ_y , the performance of all the estimators stabilizes. It can also be seen from Fig. 1 and 6 that for low values of λ_x and λ_y , say less than 0.5, the surface plots are changing, whereas when λ_x and λ_y are greater than 0.5, the plots are smooth. The behaviour of different estimators for different values of λ_x and λ_y , in particular when they are small, varies differently in different distributions.

For the t -distribution of measurement errors (Tables 3 and 4), b_g and b_b have smaller magnitude of EB than other estimators in small samples. The estimator b_d is always negatively biased, whereas the direction of bias of other estimators depends on the values of λ_x and λ_y . Comparing the EMSEs, b_b dominates all other estimators when λ_x and λ_y are low. The dominating range of λ_x and λ_y is wider in small samples than in large samples for both the EB and EMSE. The estimator b_p is adversely affected by the lower values of λ_y than λ_x in small samples. Overall, b_b emerges as a good choice when λ_x is small. When both are high, then b_p is a better choice.

Under the beta distribution of measurement errors (Tables 5 and 6), The magnitude of EB of b_g and b_b is smaller than of other estimators in small samples but in large samples, b_p has smaller magnitude of EB. Comparing the EMSEs, we find that b_d has very high EMSE when $\lambda_x \leq 0.3$, whereas b_i , b_p and b_m have high EMSE for $\lambda_x \leq 0.3$ or $\lambda_y \leq 0.3$. The estimator b_g and b_b have relatively much lower EMSE than other estimators in small samples. This remains true in large samples only when λ_x is very low, say, 0.1. Among all estimators, b_b has smaller EMSE for lower values of λ_x and λ_y . The estimator b_p outperforms b_g and b_b only when λ_x and λ_y are high in small samples and that over a wide range of values of λ_x and λ_y . In large sample, this remains true over a narrower range of values of λ_x and λ_y . Again, b_p is severely affected by the lower values of λ_y in small sample.

As λ_x and λ_y increase, the performance of all the estimators stabilize. In large samples, this stabilization comes much faster than in small samples.

Now we consider Tables 7 and 8. The values of the magnitude of EBs and EMSEs of all the estimators are higher under Weibull distributed measurement errors than the corresponding values under the other distributions. This effect is essentially due to the presence of extreme values in the sample and the shape of the Weibull distribution considered here, which is a J-shaped curve. In spite of this, b_b shows its clear dominance with respect to the magnitude of EB and EMSE over b_p and b_g in small sample when $\lambda_x \leq 0.9$ and $\lambda_y \leq 0.3$. In case of large samples, this dominance is still present, but the ranges of λ_x and λ_y shrink. Under similar conditions, b_g emerges as the second best choice of estimator. The performance of b_i and b_p is more severely affected by the lower values of λ_y than by the lower values of λ_x . The difference in the values of magnitude of EBs and EMSEs under small and large samples is higher under Weibull distributed measurement errors than under other distributions considered earlier. It can be noticed here that the performance of b_p under this case is worst among other cases considered earlier. Still b_b and b_g turns out to be more robust than b_p , and b_b emerges as winner.

5 Conclusions :

We considered six estimators b_d , b_i , b_p , b_g , b_m , and b_b for the slope parameter β when the error variances σ_u^2 and σ_v^2 are known in a linear ultrastructural model. These estimators can be regarded as arising from the method of moments. All these estimators are found to be consistent and asymptotically normally distributed.

When the distributions of errors depart from normality, it is interesting to observe that the asymptotic variances of the estimators are influence by the peakedness, and not the asymmetry, of the error distributions. Further it is seen that

the superiority of an estimator over another under the popular specification of normality may not necessarily carry over when the distributions depart from normality. For example, the uniform superiority of the estimator b_p over b_g , b_m , and b_b is perturbed when the distributions are not normal and in particular platykurtic.

A study from a Monte Carlo simulation experiment gives an insight into the finite sample properties of the estimators and the effect of departure from normality on the efficiency properties of the estimators. It is clear from the study that the efficiency properties of the estimators are affected by non-normality of the distribution of measurement errors. In particular, the effect of peakedness is clearly seen, which is more pronounced in small samples than in large samples. For large samples, most of the estimators show a behaviour that corresponds to the asymptotic theory, at least for higher values of reliability ratios. As a rule of thumb, the reliability ratios can be said to be large when $\lambda_x \geq 0.5$ and $\lambda_y \geq 0.5$. In particular, when n , λ_x , and λ_y are large, then b_p is best. Also, in this case b_g , b_m , and b_b are almost similar, which is in accordance with the asymptotic theory. For lower values of the reliability ratios, there is no unique dominance of any of the estimators. The uniform superiority of b_p is questionable when the values of the reliability ratios are very low under not necessarily normally distributed measurement errors. In most of the cases, b_b emerges as a better choice than b_p when λ_x and λ_y are low (although otherwise b_p dominates). If λ_x and λ_y are small, very large samples are needed to produce results similar to asymptotic theory; $n = 400$ is not large enough. It is revealed from the simulation study that the choice of a good estimator depends on the values of the reliability ratios as well as the distribution of measurement errors under consideration.

6 Appendix

Using the fundamental relations of the model (2.1)-(2.3), we find with some algebra

$$\sqrt{n}(\hat{\beta}_d - \beta) = \frac{\sqrt{n}}{s_x^2 - \sigma_v^2} Z_d,$$

where

$$Z_d = s_{Xu} + s_{uv} - \beta s_{Xv} - \beta(s_v^2 - \sigma_v^2).$$

Denoting the centralised variable X by $X^* = X - \mu_X$, we obtain

$$\sqrt{n}Z_d = \frac{1}{\sqrt{n}} \sum_{j=1}^n [X_j^* u_j + u_j v_j - \beta X_j^* v_j - \beta(v_j^2 - \sigma_v^2)] + o_p(1).$$

Similarly,

$$\sqrt{n}(\hat{\beta}_i - \beta) = \frac{\sqrt{n}}{s_{xy}} Z_i$$

with

$$\sqrt{n}Z_i = \frac{1}{\sqrt{n}} \sum_{j=1}^n [\beta X_j^* u_j - \beta u_j v_j - \beta^2 X_j^* v_j + u_j^2 - \sigma_u^2] + o_p(1).$$

By the central limit theorem,

$$\sqrt{n} \begin{pmatrix} Z_d \\ Z_i \end{pmatrix} \rightarrow N(0, \Sigma_Z), \quad \text{where } \Sigma_Z = \begin{pmatrix} \sigma_{Z_d Z_d} & \sigma_{Z_d Z_i} \\ \sigma_{Z_d Z_i} & \sigma_{Z_i Z_i} \end{pmatrix}$$

with

$$\begin{aligned} \sigma_{Z_d Z_d} &= \sigma_X^2 \sigma_u^2 + \sigma_u^2 \sigma_v^2 + \beta^2 \sigma_X^2 \sigma_v^2 + \beta^2 (E(v^4) - \sigma_v^4) \\ \sigma_{Z_i Z_i} &= \beta^2 \sigma_X^2 \sigma_u^2 + \beta^2 \sigma_u^2 \sigma_v^2 + \beta^4 \sigma_X^2 \sigma_v^2 + E(u^4) - \sigma_u^4 \\ \sigma_{Z_d Z_i} &= \beta \sigma_X^2 \sigma_u^2 - \beta \sigma_u^2 \sigma_v^2 + \beta^3 \sigma_X^2 \sigma_v^2. \end{aligned}$$

As $\text{plim}_{n \rightarrow \infty} (s_x^2 - \sigma_v^2) = \sigma_X^2$ and $\text{plim}_{n \rightarrow \infty} s_{xy} = \beta \sigma_X^2$, we finally obtain

$$\begin{aligned} \sigma_{dd} &= \frac{1}{\sigma_X^4} [\sigma_u^2 (\sigma_X^2 + \sigma_v^2) + \beta^2 \sigma_X^2 \sigma_v^2 + \beta^2 (\gamma_{2v} + 2) \sigma_v^4] \\ \sigma_{ii} &= \frac{1}{\sigma_X^4} \left[\sigma_u^2 (\sigma_X^2 + \sigma_v^2) + \beta^2 \sigma_X^2 \sigma_v^2 + \frac{1}{\beta^2} (\gamma_{2u} + 2) \sigma_u^4 \right] \\ \sigma_{di} &= \frac{1}{\sigma_X^4} [\sigma_u^2 (\sigma_X^2 - \sigma_v^2) + \beta^2 \sigma_X^2 \sigma_v^2] \end{aligned}$$

Using the definitions of λ_x and q , one can see the equivalence of these expressions to the corresponding ones in Proposition 1.

Proof of Proposition 3:

Denote the partial derivatives of g with respect to the first and second argument of g by g_1 and g_2 , respectively. Then by the symmetry of g , the equation $\beta = g(\beta, \beta)$ implies

$$1 = g_1(\beta, \beta) + g_2(\beta, \beta) = 2g_1(\beta, \beta) = 2g_2(\beta, \beta),$$

i.e., $g_1(\beta, \beta) = g_2(\beta, \beta) = \frac{1}{2}$. We then can evaluate $\sigma_{\hat{\beta}}^2$ by the delta-method as

$$\sigma_{\hat{\beta}}^2 = \frac{1}{4}(1, 1)\Sigma(1, 1)'$$

which is the statement of Proposition 3.

Acknowledgement

The second author acknowledges the support from a SERC project from the Department of Science and Technology, Government of India and SFB 386, University of Munich (Germany).

References

- Aaronsom, M., G. Bothum, J. Mould, J. Huchra, R.A. Schommer and M.E. Cornell (1986): ‘A distance scale from the infrared magnitude /HI velocity-width relation. ν . distance moduli to 10 galaxy clusters, and positive detection of bulk supercluster motion toward the microwave anisotropy’, *Astrophysical Journal*, **302**, pp. 536-563.
- Cheng, C.L. and J.W. Van Ness (1999): **Statistical Regression with Measurement Errors**, Arnold Publishers.

- Dorff, M. and J. Gurland (1961): ‘Estimation of parameters of a linear functional relation’, *Journal of the Royal Statistical Society, Series B*, Vol. 23, **No. 1**, pp. 160-170.
- Gleser, L.J. (1992): ‘The importance of assessing measurement reliability in multivariate regression’, *Journal of American Statistical Association*, **87**, 419, pp. 696-407.
- Gleser, L.J. (1993): ‘Estimation of slope in linear errors-in-variables regression models when the predictors have known reliability matrix’, *Statistics and Probability Letters*, **17 (2)**, pp. 113-121.
- Fuller, W.A. (1987): **Measurement Error Models**, John Wiley.
- Pierce, M.J. and R.B. Tully (1988): ‘Distances to virgo and ursa major clusters and a determination of H_0 ’, *Astrophysical Journal*, **330**, pp. 579-595.
- Schneeweiss, H. (1976): ‘Consistent estimation of a regression with errors in the variables’, *Metrika*, **23**, pp. 101-115.
- Shalabh (1998): ‘Improved estimation in measurement error models through Stein-rule procedure’, *Journal of Multivariate Analysis*, **67**, 35-48.
- Corrigendum : *Journal of Multivariate Analysis*, **74**, p. 162, (2000).
- Shalabh, L.J. Gleser, and O. Rosen (2004): ‘On the usefulness of knowledge of error variances in the consistent estimation of an unreplicated ultrastructural model’, *Journal of Statistical Computational & Simulation*, **74**, 6 pp. 391-417.
- Sokal, R.R. and F.J. Rohlf (1981): **Biometry: The principal and Practice of Statistics in Biological Research**, Second Edition, Freeman.

Srivastava, A.K. and Shalabh (1997 a): ‘A new property of Stein procedure in measurement error model’, *Statistics & Probability Letters*, **32**, pp. 231-234.

Srivastava, A.K. and Shalabh (1997b): ‘Consistent estimation for the non-normal ultrastructural model’, *Statistics & Probability Letters*, **34**, pp. 67-73.

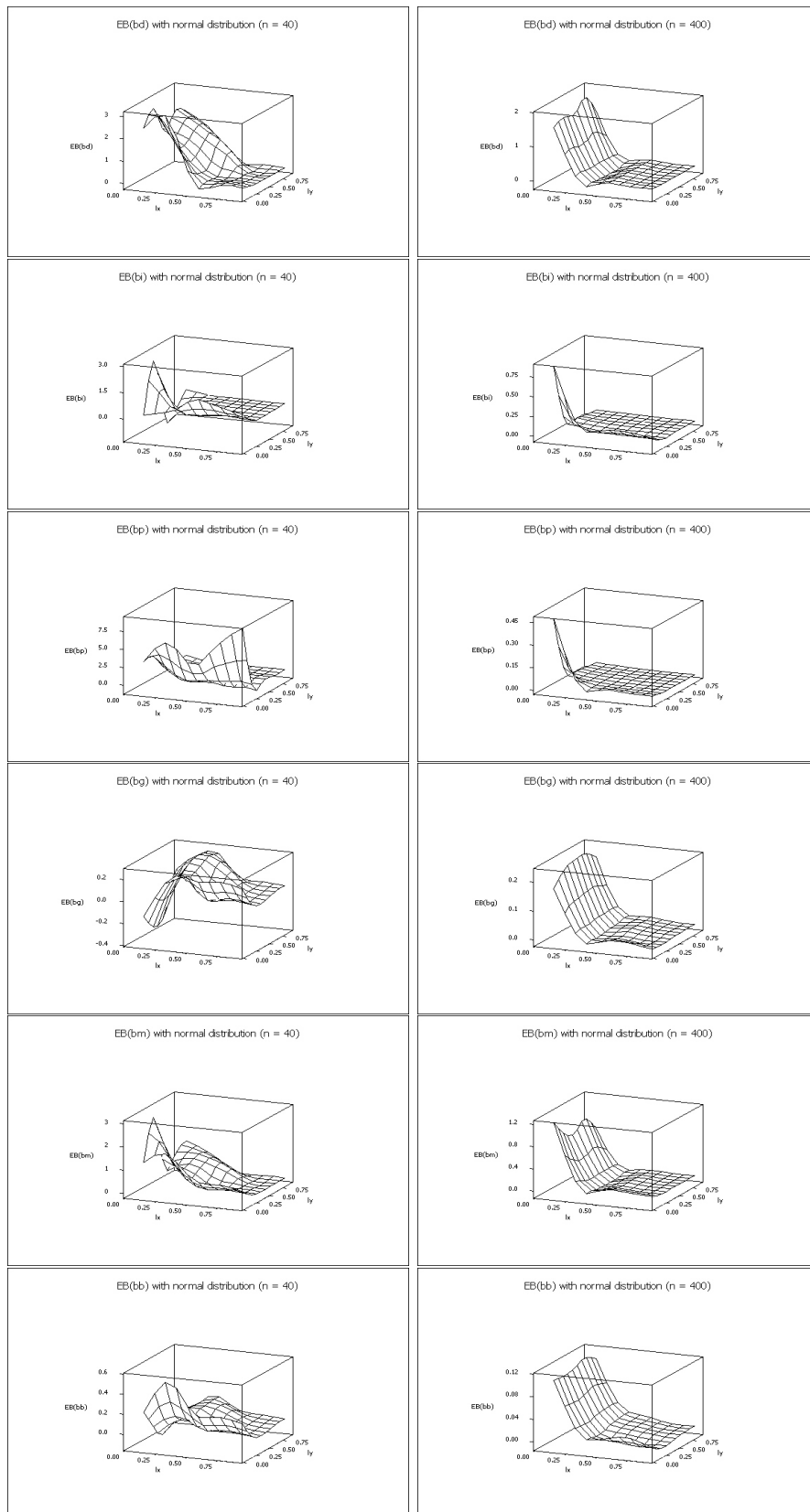

21
 Figure 1: Empirical bias of estimators when measurement errors follow normal distribution

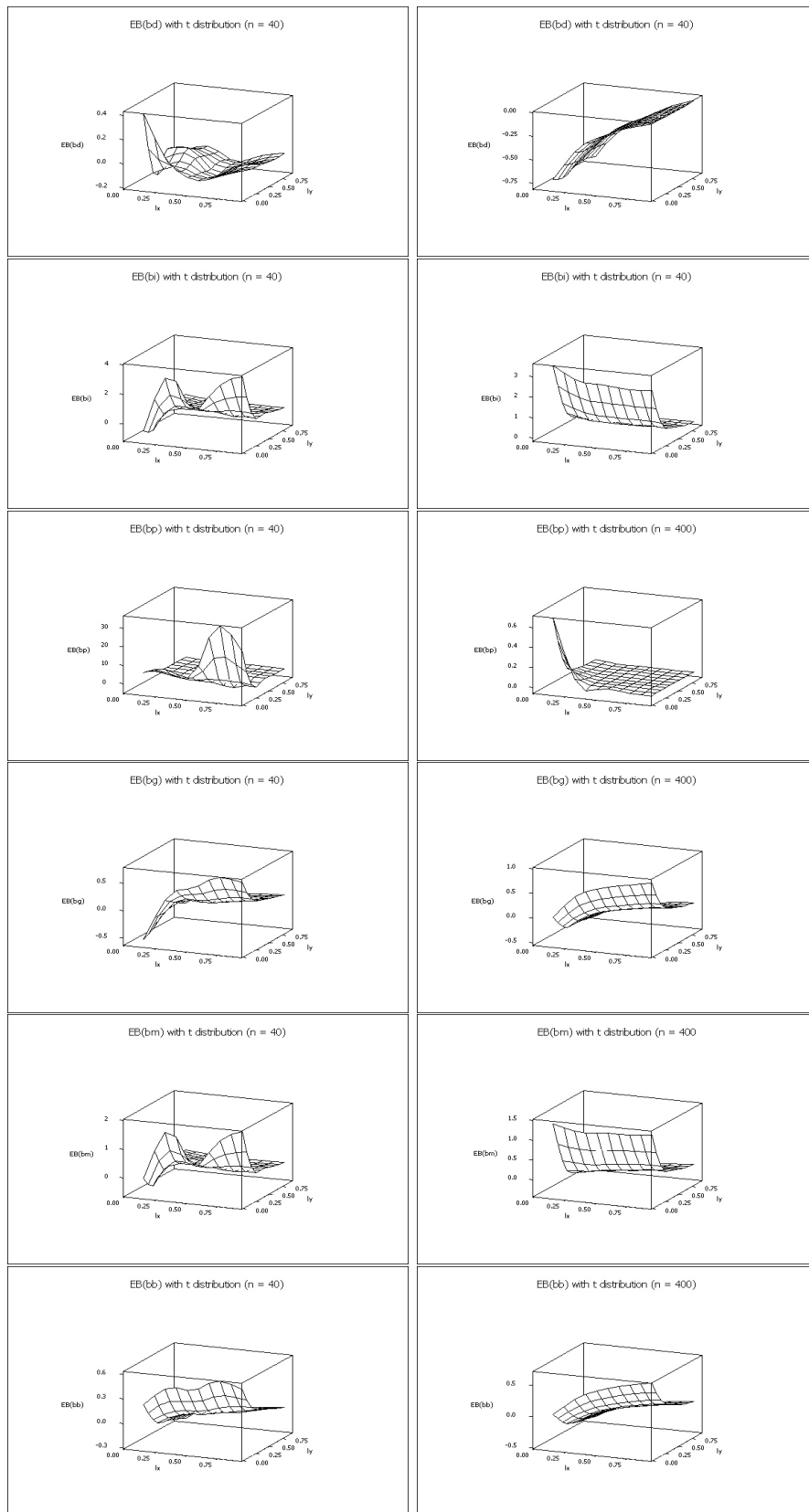

22

Figure 2: Empirical bias of estimators when measurement errors follow t - distribution

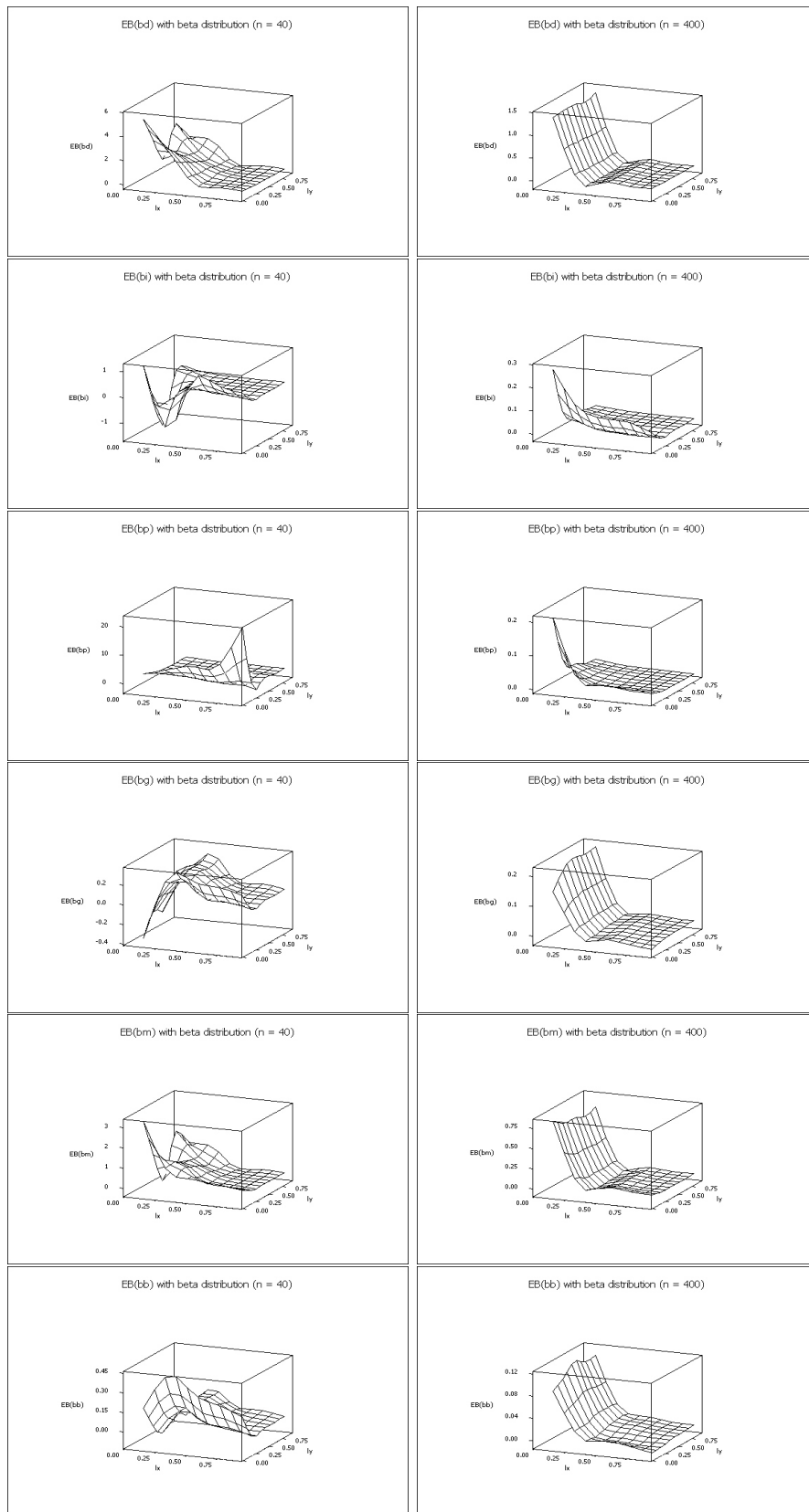

23

Figure 3: Empirical bias of estimators when measurement errors follow beta distribution

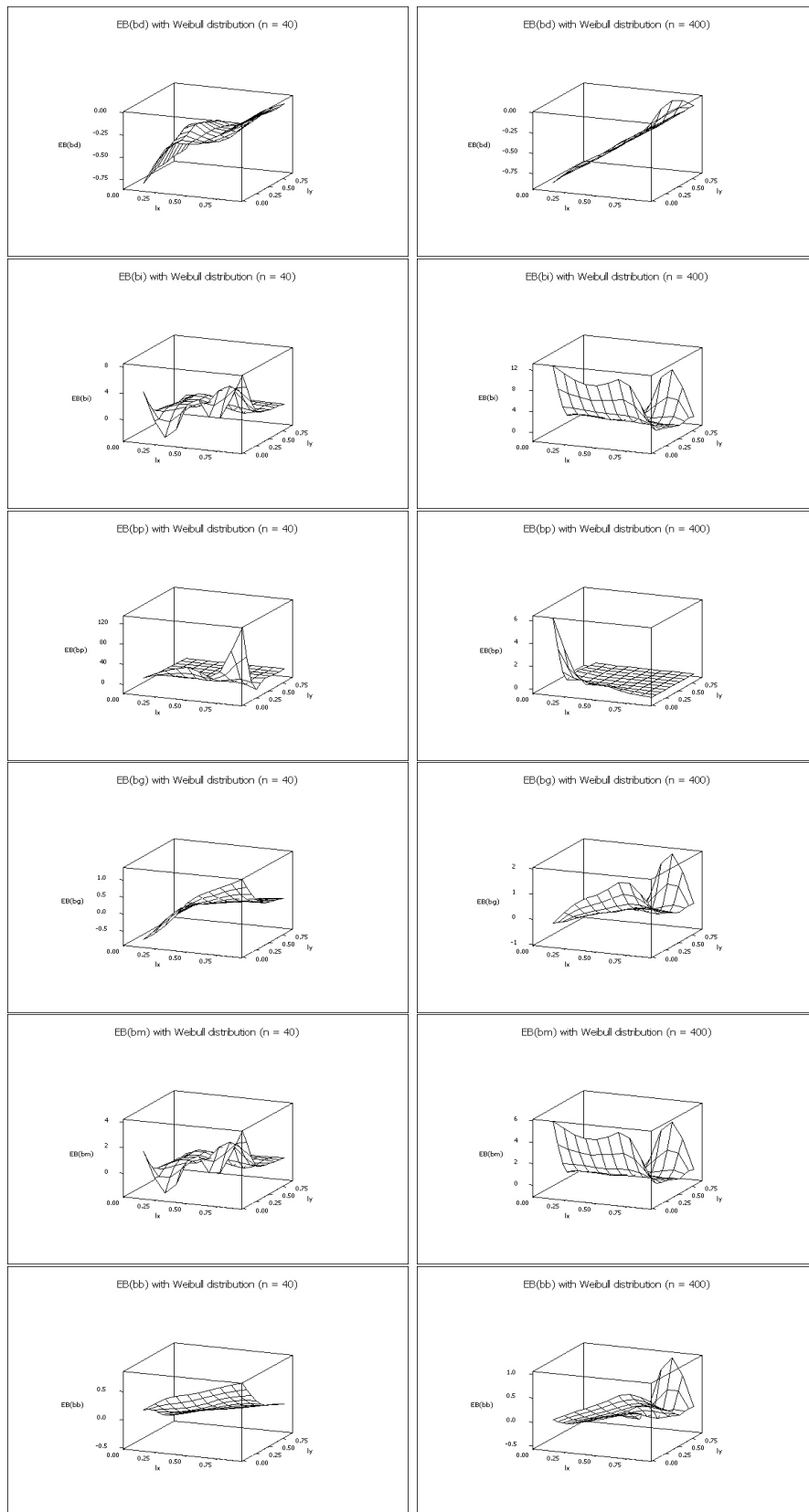

24

Figure 4: Empirical bias of estimators when measurement errors follow Weibull distribution

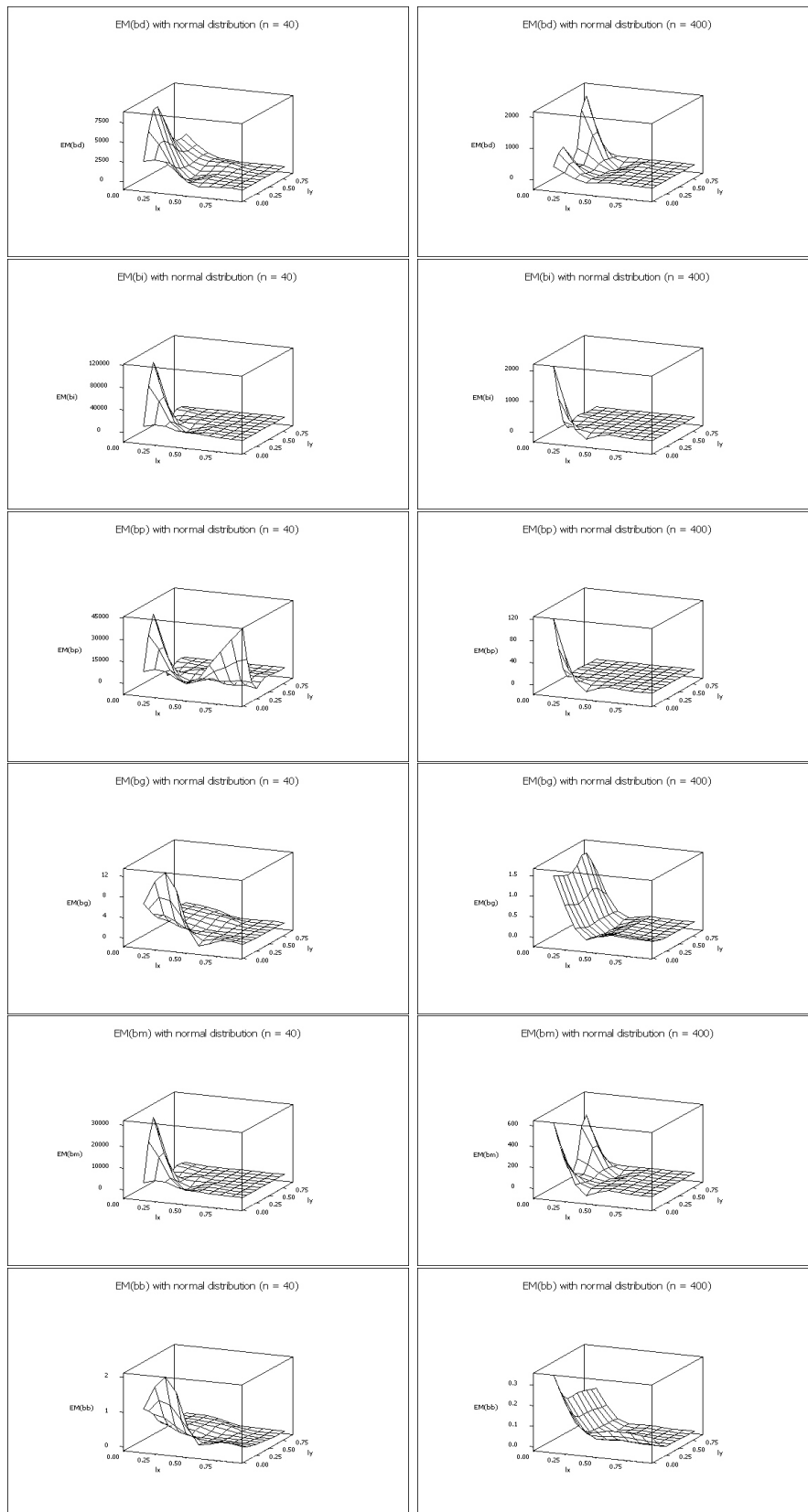

25

Figure 5: Empirical mean squared error of estimators when measurement errors follow normal distribution

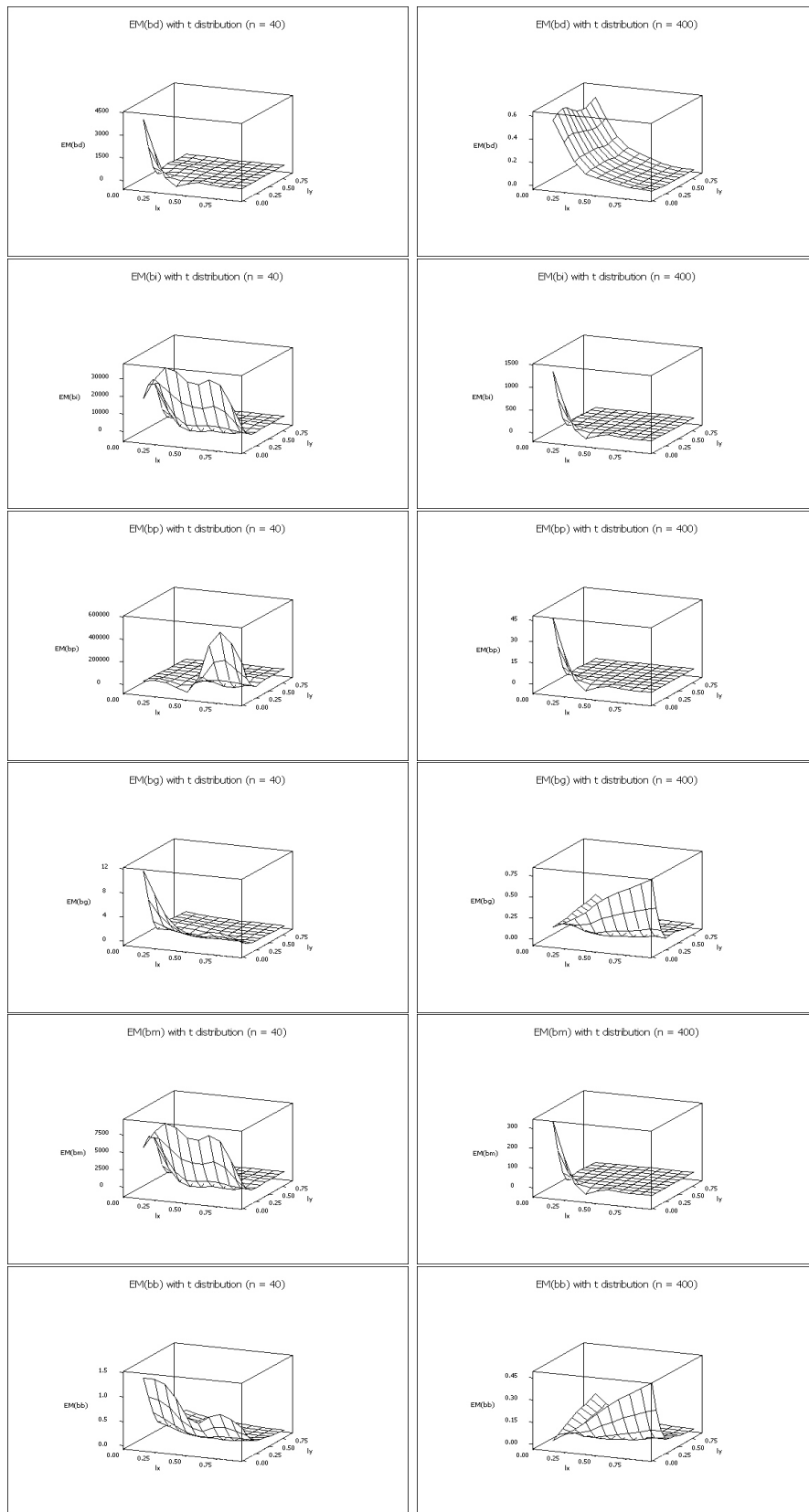

26

Figure 6: Empirical mean squared error of estimators when measurement errors follow t - distribution

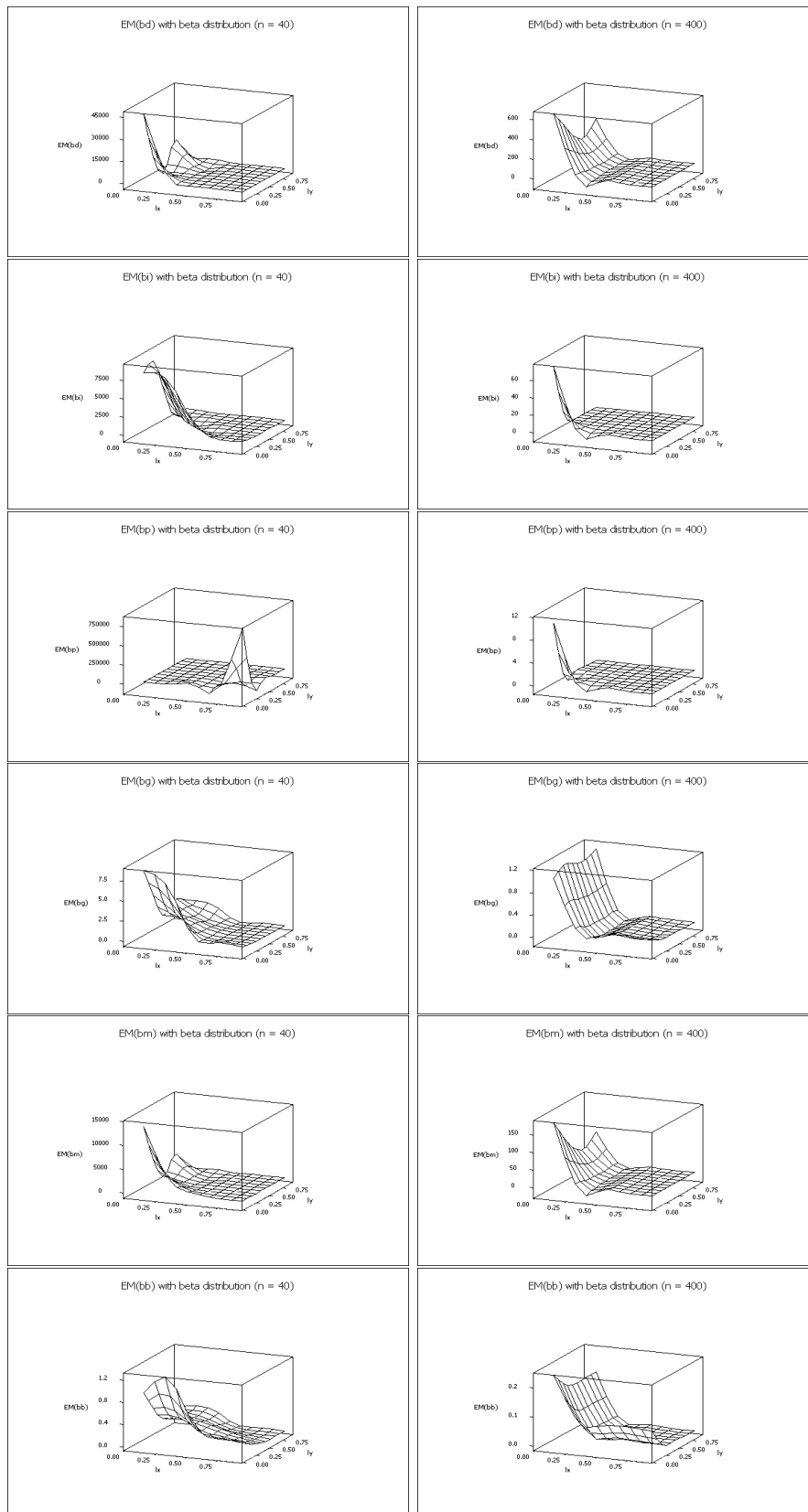

27

Figure 7: Empirical mean squared error of estimators when measurement errors follow beta distribution

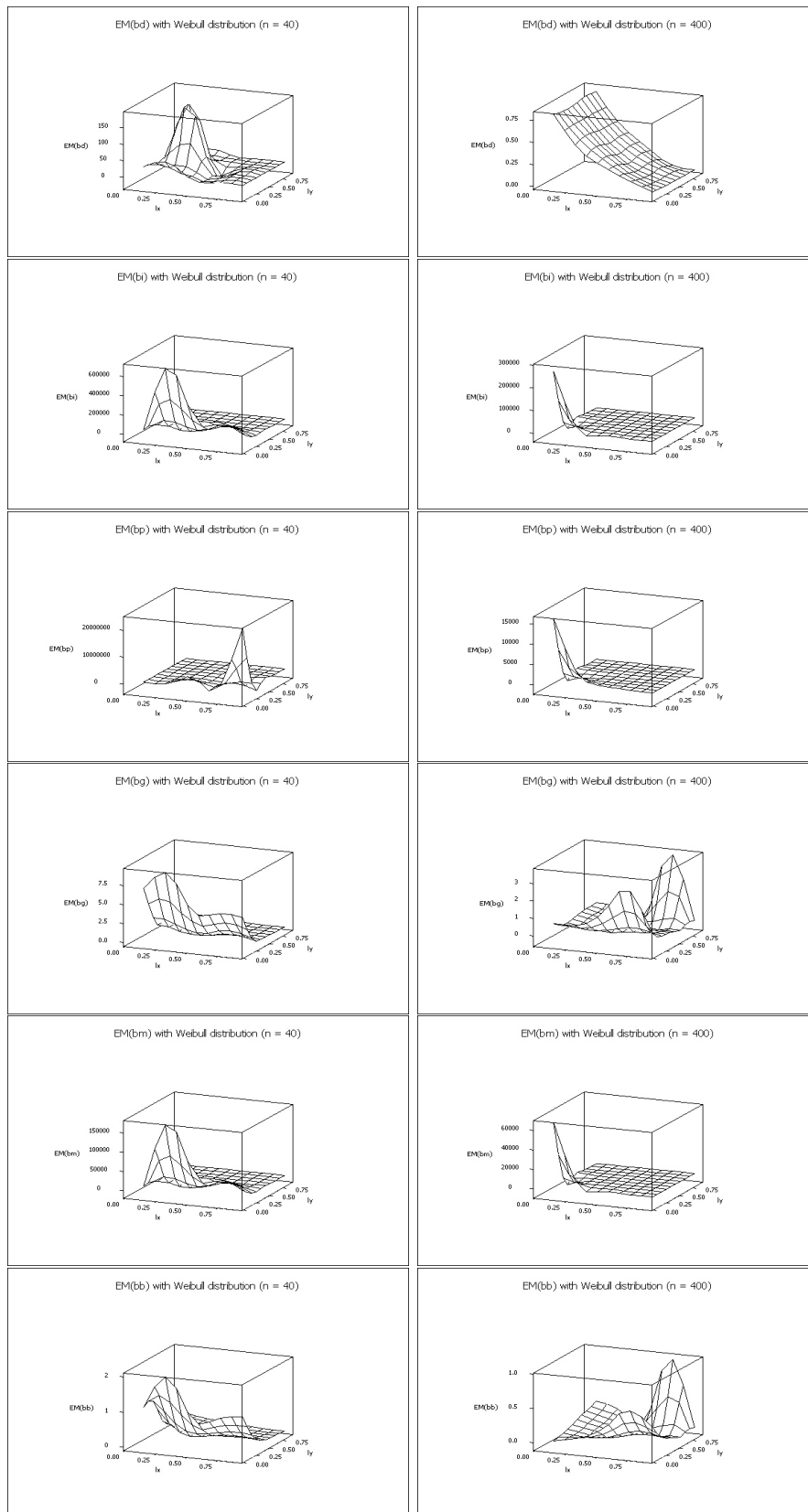

28
 Figure 8: Empirical mean squared error of estimators when measurement errors follow Weibull distribution

Table 1: Empirical bias and empirical mean squared error of estimators under Normal distribution with $n = 40$

λ_x	λ_y	EB(b_d)	EB(b_i)	EB(b_p)	EB(b_g)	EB(b_m)	EB(b_h)	EM(b_d)	EM(b_i)	EM(b_p)	EM(b_g)	EM(b_m)	EM(b_h)
0.1	0.1	2.3778	0.0970	2.9837	-0.1515	1.2374	0.1975	2338.3347	7264.9626	6709.6897	6.2713	2398.4482	1.0259
0.1	0.3	2.9533	2.8197	2.8159	-0.3068	2.8865	-0.0222	8372.1153	111120.0222	42061.1781	2.8358	29870.8681	0.6654
0.1	0.5	1.7780	-0.6190	0.6149	-0.2269	0.5795	-0.1179	5923.5753	3567.5583	93.0300	1.9777	2370.1402	0.2807
0.1	0.7	2.3664	-0.6878	0.4615	0.0995	0.8393	-0.0085	2802.5079	2678.2760	95.1404	2.1896	1365.6555	0.2606
0.1	0.9	2.1095	0.2171	0.6023	-0.0443	1.1633	-0.0990	2826.3566	340.8706	220.4229	1.8770	788.4409	0.2409
0.3	0.1	2.8708	0.4338	5.9250	0.1972	1.6523	0.5203	2251.0402	9980.3723	7099.3082	12.2690	3057.0210	1.9476
0.3	0.3	1.2964	0.1434	0.1897	0.1782	0.7199	0.1098	551.5361	18.9549	4.5883	1.5134	141.6754	0.3282
0.3	0.5	1.2066	0.0757	0.1019	0.2178	0.6412	0.1270	193.5423	7.6577	4.4940	1.1156	49.3896	0.2566
0.3	0.7	1.7229	0.0462	0.0541	0.2679	0.8846	0.1423	539.3231	0.3843	0.2092	1.6768	132.9626	0.2586
0.3	0.9	1.4246	0.0375	0.0402	0.2538	0.7311	0.1532	574.9005	0.0752	0.0734	1.4015	142.4724	0.2210
0.5	0.1	0.2370	1.2395	3.3103	0.2255	0.7383	0.2484	0.6897	2961.1664	3129.7889	0.5652	740.7227	0.3633
0.5	0.3	0.1369	0.0160	0.0648	0.0146	0.0765	0.0199	0.2907	9.8367	0.7767	0.1461	2.5301	0.1241
0.5	0.5	0.2153	-0.0013	0.0337	0.0501	0.1070	0.0410	10.2123	0.1400	0.0868	0.1738	2.5832	0.0995
0.5	0.7	1.0319	0.0385	0.0557	0.1801	0.5352	0.1161	495.7989	0.3371	0.2566	1.0050	123.4030	0.1862
0.5	0.9	0.1441	0.0195	0.0242	0.0684	0.0818	0.0639	0.3668	0.0309	0.0310	0.0742	0.1091	0.0606
0.7	0.1	0.1407	1.0427	6.4010	0.2252	0.5917	0.2246	0.2856	923.0087	23173.2076	0.4311	231.0029	0.2809
0.7	0.3	0.0872	0.1391	0.1757	0.0130	0.1132	0.0234	0.1468	41.0841	34.1450	0.1577	10.2917	0.1304
0.7	0.5	0.0516	-0.0271	0.0187	-0.0108	0.0123	-0.0077	0.0841	0.1464	0.0598	0.0744	0.0692	0.0688
0.7	0.7	0.0401	-0.0081	0.0094	0.0106	0.0160	0.0104	0.0481	0.0384	0.0290	0.0310	0.0303	0.0306
0.7	0.9	0.0322	0.0041	0.0089	0.0167	0.0182	0.0166	0.0222	0.0134	0.0129	0.0146	0.0141	0.0146
0.9	0.1	0.1475	0.7103	9.0688	0.1845	0.4289	0.1820	0.1935	33.1108	43389.9527	0.3114	8.5843	0.2369
0.9	0.3	0.0428	0.0333	0.0392	-0.0127	0.0381	-0.0031	0.0730	0.3900	0.0699	0.1263	0.1277	0.1074
0.9	0.5	0.0130	-0.0547	0.0048	-0.0389	-0.0209	-0.0344	0.0429	0.1352	0.0406	0.0660	0.0597	0.0602
0.9	0.7	0.0097	-0.0173	0.0027	-0.0059	-0.0038	-0.0058	0.0168	0.0252	0.0155	0.0170	0.0168	0.0169
0.9	0.9	0.0078	-0.0021	0.0026	0.0026	0.0029	0.0026	0.0060	0.0057	0.0053	0.0053	0.0053	0.0053

Table 2: Empirical bias and empirical mean squared error of estimators under normal distribution with $n = 400$

λ_x	λ_y	EB(b_{d1})	EB(b_i)	EB(b_p)	EB(b_g)	EB(b_m)	EB(b_b)	EM(b_d)	EM(b_i)	EM(b_p)	EM(b_g)	EM(b_m)	EM(b_b)
0.1	0.1	1.5263	0.8652	0.4645	0.1700	1.1958	0.1055	362.1555	2088.5915	117.7558	1.4587	612.3902	0.3387
0.1	0.3	1.6531	0.1151	0.0826	0.2166	0.8841	0.1038	781.7218	10.8039	8.1235	1.3126	198.1202	0.2025
0.1	0.5	1.5786	0.0334	0.0260	0.2310	0.8060	0.1078	292.5039	0.0727	0.0608	1.3400	73.2393	0.1875
0.1	0.7	1.8775	0.0211	0.0194	0.2305	0.9493	0.1148	2023.7957	0.0385	0.0363	1.5824	506.0309	0.1778
0.1	0.9	1.3156	0.0145	0.0139	0.2003	0.6651	0.1028	444.2833	0.0274	0.0270	1.0409	111.1333	0.1617
0.3	0.1	0.0607	0.1471	0.0449	0.0117	0.1039	0.0180	0.1466	0.9675	0.2044	0.1255	0.2490	0.1014
0.3	0.3	0.0648	0.0081	0.0151	0.0168	0.0365	0.0158	0.1098	0.0713	0.0335	0.0382	0.0847	0.0357
0.3	0.5	0.0566	0.0071	0.0100	0.0221	0.0319	0.0211	0.0788	0.0226	0.0166	0.0236	0.0274	0.0223
0.3	0.7	0.0575	0.0064	0.0082	0.0254	0.0320	0.0246	0.0659	0.0107	0.0100	0.0198	0.0225	0.0189
0.3	0.9	0.0524	0.0060	0.0066	0.0244	0.0292	0.0238	0.0533	0.0070	0.0069	0.0169	0.0187	0.0163
0.5	0.1	0.0202	0.1084	0.0213	0.0025	0.0643	0.0096	0.0537	0.4345	0.0465	0.1076	0.1141	0.0870
0.5	0.3	0.0115	-0.0033	0.0033	-0.0042	0.0041	-0.0039	0.0216	0.0489	0.0156	0.0190	0.0189	0.0186
0.5	0.5	0.0125	-0.0001	0.0031	0.0030	0.0062	0.0030	0.0158	0.0155	0.0089	0.0090	0.0092	0.0090
0.5	0.7	0.0160	0.0015	0.0036	0.0071	0.0088	0.0071	0.0125	0.0061	0.0052	0.0060	0.0061	0.0060
0.5	0.9	0.0181	0.0022	0.0030	0.0090	0.0102	0.0089	0.0127	0.0040	0.0039	0.0057	0.0059	0.0057
0.7	0.1	0.0160	0.1232	0.0181	0.0094	0.0696	0.0165	0.0384	0.4583	0.0365	0.1178	0.1228	0.0938
0.7	0.3	0.0030	-0.0095	0.0007	-0.0086	-0.0033	-0.0083	0.0103	0.0410	0.0095	0.0158	0.0153	0.0154
0.7	0.5	0.0028	-0.0038	0.0005	-0.0016	-0.0005	-0.0016	0.0049	0.0088	0.0042	0.0047	0.0047	0.0047
0.7	0.7	0.0043	-0.0009	0.0013	0.0013	0.0017	0.0013	0.0031	0.0030	0.0023	0.0023	0.0023	0.0023
0.7	0.9	0.0029	-0.0001	0.0004	0.0013	0.0014	0.0013	0.0020	0.0014	0.0013	0.0014	0.0014	0.0014
0.9	0.1	0.0132	0.0759	0.0136	-0.0042	0.0446	0.0046	0.0261	0.3563	0.0258	0.1052	0.0994	0.0845
0.9	0.3	0.0015	-0.0085	0.0010	-0.0068	-0.0035	-0.0066	0.0062	0.0290	0.0062	0.0117	0.0114	0.0115
0.9	0.5	-0.0001	-0.0057	-0.0007	-0.0036	-0.0029	-0.0036	0.0028	0.0073	0.0028	0.0037	0.0037	0.0037
0.9	0.7	0.0008	-0.0012	0.0003	-0.0003	-0.0002	-0.0003	0.0014	0.0020	0.0013	0.0014	0.0014	0.0014
0.9	0.9	0.0011	-0.0001	0.0005	0.0005	0.0005	0.0005	0.0007	0.0007	0.0006	0.0006	0.0006	0.0006

Table 3: Empirical bias and empirical mean squared error of estimators under t -distribution with $n = 40$

λ_x	λ_y	EB(b_d)	EB(b_i)	EB(b_p)	EB(b_g)	EB(b_m)	EB(b_b)	EM(b_d)	EM(b_i)	EM(b_p)	EM(b_g)	EM(b_m)	EM(b_b)
0.1	0.1	0.4000	-0.6089	4.9963	-0.5659	-0.1044	0.2049	3928.4291	17748.1352	12305.0360	11.3439	5424.3516	1.3467
0.1	0.3	-0.1568	-0.8486	2.7583	-0.4385	-0.5027	-0.0681	182.9615	24064.2121	7897.0124	1.4534	6062.5843	0.4561
0.1	0.5	-0.0277	0.7433	1.0337	-0.2052	0.3578	-0.1453	66.4330	2003.0079	1105.6039	0.7620	517.1782	0.2310
0.1	0.7	-0.0361	0.5129	0.6628	-0.2226	0.2384	-0.1852	67.7748	195.0094	103.4194	0.7345	65.6022	0.2099
0.1	0.9	-0.1017	0.2904	0.6990	-0.3298	0.0943	-0.2478	80.5722	146.9337	64.0038	0.7439	56.8242	0.2206
0.3	0.1	0.0263	3.2026	7.5230	0.2551	1.6144	0.4319	26.0959	36469.0970	11031.6554	3.8883	9124.3829	1.2039
0.3	0.3	-0.0610	0.7834	0.7090	0.0749	0.3612	0.0738	17.8776	2218.9915	620.2413	0.5545	559.2082	0.2233
0.3	0.5	0.0096	0.4394	0.1860	0.0088	0.2245	-0.0018	97.2623	36.6489	1.2790	0.5812	33.5527	0.1606
0.3	0.7	-0.0301	0.2575	0.1261	-0.0449	0.1137	-0.0542	25.3782	2.5789	0.9842	0.4175	7.0394	0.1430
0.3	0.9	-0.0512	0.0955	0.0703	-0.0693	0.0222	-0.0745	47.1431	0.7444	0.5626	0.2443	12.0026	0.0983
0.5	0.1	-0.1065	1.3143	7.5511	0.4802	0.6039	0.4450	0.4690	28970.6508	8322.1818	1.5639	7243.4382	0.5549
0.5	0.3	-0.1267	0.6676	0.1599	0.1152	0.2705	0.1007	0.1403	263.8139	37.7573	0.1424	65.9045	0.1134
0.5	0.5	-0.1476	0.5659	0.1242	0.0486	0.2091	0.0442	0.1959	55.2721	2.7793	0.1115	13.7622	0.0940
0.5	0.7	-0.1217	0.2266	0.0687	-0.0136	0.0525	-0.0161	2.7116	0.5931	0.3324	0.1408	0.8305	0.0820
0.5	0.9	-0.1464	0.0874	0.0431	-0.0583	-0.0295	-0.0570	0.2630	0.1396	0.0633	0.0690	0.1064	0.0588
0.7	0.1	-0.0641	2.8201	33.5894	0.7026	1.3780	0.5813	0.4678	30816.6456	500127.1361	2.3406	7704.7732	0.7491
0.7	0.3	-0.0751	0.7472	0.1427	0.2008	0.3360	0.1747	0.1003	38.6150	45.2990	0.1913	9.6392	0.1435
0.7	0.5	-0.0689	0.2463	0.0173	0.0622	0.0887	0.0593	0.0456	0.2148	0.0533	0.0482	0.0627	0.0451
0.7	0.7	-0.0974	0.1661	0.0206	0.0132	0.0344	0.0126	0.0545	0.1988	0.0984	0.0360	0.0602	0.0345
0.7	0.9	-0.0847	0.0498	0.0146	-0.0233	-0.0174	-0.0230	0.0337	0.0253	0.0204	0.0180	0.0178	0.0178
0.9	0.1	0.0085	3.7527	21.8519	0.6584	1.8806	0.5103	0.2075	6715.3378	258416.7557	1.0600	1678.1940	0.5277
0.9	0.3	-0.0202	0.7433	0.0135	0.2385	0.3615	0.2115	0.0707	2.5409	0.0781	0.1978	0.6287	0.1571
0.9	0.5	-0.0310	0.3975	0.0125	0.1369	0.1832	0.1280	0.0454	0.6067	0.0523	0.0893	0.1613	0.0787
0.9	0.7	-0.0455	0.2155	0.0090	0.0670	0.0850	0.0648	0.0316	0.1535	0.0356	0.0394	0.0480	0.0372
0.9	0.9	-0.0430	0.0592	0.0058	0.0051	0.0081	0.0051	0.0154	0.0212	0.0135	0.0118	0.0121	0.0117

Table 4: Empirical bias and empirical mean squared error of estimators under t -distribution with $n = 400$

λ_x	λ_y	EB(b_d)	EB(b_i)	EB(b_p)	EB(b_g)	EB(b_m)	EB(b_n)	EM(b_d)	EM(b_i)	EM(b_p)	EM(b_g)	EM(b_m)	EM(b_n)
0.1	0.1	-0.7279	3.4397	0.6754	-0.0217	1.3559	0.0058	0.5520	1309.4244	45.3695	0.1182	326.1755	0.0105
0.1	0.3	-0.7711	1.1649	0.1779	-0.3422	0.1969	-0.2215	0.6043	94.9929	4.6695	0.1330	23.4267	0.0580
0.1	0.5	-0.7229	0.3776	0.0485	-0.3994	-0.1727	-0.3182	0.5304	0.2780	0.0857	0.1674	0.0591	0.1072
0.1	0.7	-0.7018	0.1525	0.0293	-0.4236	-0.2747	-0.3602	0.4993	0.0674	0.0368	0.1856	0.0855	0.1342
0.1	0.9	-0.7338	0.0678	0.0268	-0.4757	-0.3330	-0.4062	0.5443	0.0401	0.0335	0.2317	0.1192	0.1689
0.3	0.1	-0.3870	2.8473	0.0488	0.4673	1.2302	0.3052	0.1792	11.9248	0.2407	0.2670	2.3967	0.1152
0.3	0.3	-0.4259	0.8179	0.0232	0.0072	0.1960	0.0053	0.1953	0.8242	0.0525	0.0150	0.0735	0.0109
0.3	0.5	-0.4300	0.3558	0.0113	-0.1277	-0.0371	-0.1164	0.1949	0.1677	0.0246	0.0245	0.0123	0.0204
0.3	0.7	-0.4076	0.1423	0.0090	-0.1808	-0.1327	-0.1714	0.1741	0.0337	0.0112	0.0381	0.0228	0.0341
0.3	0.9	-0.4365	0.0479	0.0053	-0.2345	-0.1943	-0.2239	0.1979	0.0107	0.0078	0.0596	0.0418	0.0541
0.5	0.1	-0.2183	2.7408	0.0147	0.6697	1.2613	0.4781	0.0741	8.8755	0.0525	0.5009	1.8963	0.2539
0.5	0.3	-0.2384	0.7684	0.0100	0.1522	0.2650	0.1369	0.0679	0.6884	0.0223	0.0367	0.0946	0.0295
0.5	0.5	-0.2373	0.3259	0.0049	0.0026	0.0443	0.0024	0.0632	0.1284	0.0111	0.0062	0.0093	0.0057
0.5	0.7	-0.2440	0.1516	0.0092	-0.0697	-0.0462	-0.0684	0.0651	0.1866	0.1581	0.0107	0.0447	0.0085
0.5	0.9	-0.2710	0.0492	0.0027	-0.1267	-0.1109	-0.1244	0.0786	0.0067	0.0039	0.0191	0.0151	0.0183
0.7	0.1	-0.1061	2.6604	0.0036	0.7776	1.2771	0.5856	0.0346	8.1520	0.0303	0.6587	1.8764	0.3686
0.7	0.3	-0.1197	0.7734	0.0045	0.2436	0.3268	0.2259	0.0225	0.6791	0.0116	0.0724	0.1284	0.0615
0.7	0.5	-0.1246	0.3450	0.0026	0.0831	0.1102	0.0808	0.0202	0.1380	0.0064	0.0123	0.0186	0.0116
0.7	0.7	-0.1229	0.1448	0.0018	0.0014	0.0110	0.0014	0.0181	0.0263	0.0034	0.0026	0.0028	0.0025
0.7	0.9	-0.1284	0.0437	0.0010	-0.0465	-0.0424	-0.0463	0.0188	0.0039	0.0018	0.0037	0.0033	0.0037
0.9	0.1	-0.0358	2.7099	-0.0015	0.8633	1.3370	0.6632	0.0226	8.3576	0.0230	0.8044	2.0235	0.4673
0.9	0.3	-0.0368	0.7489	0.0007	0.2933	0.3561	0.2773	0.0077	0.6298	0.0069	0.0983	0.1458	0.0870
0.9	0.5	-0.0398	0.3454	0.0003	0.1352	0.1528	0.1327	0.0048	0.1360	0.0036	0.0232	0.0292	0.0223
0.9	0.7	-0.0387	0.1433	0.0003	0.0480	0.0523	0.0478	0.0031	0.0243	0.0017	0.0041	0.0046	0.0041
0.9	0.9	-0.0365	0.0380	0.0000	0.0000	0.0007	0.0000	0.0020	0.0022	0.0007	0.0006	0.0006	0.0006

Table 5: Empirical bias and empirical mean squared error of estimators under Beta distribution with $n = 40$

λ_x	λ_y	EB(b_d)	EB(b_i)	EB(b_p)	EB(b_g)	EB(b_m)	EB(b_b)	EM(b_d)	EM(b_i)	EM(b_p)	EM(b_g)	EM(b_m)	EM(b_b)
0.1	0.1	5.2655	1.1574	2.7969	-0.3579	3.2115	0.1684	46304.3919	8272.0037	4736.4953	8.5796	13644.8190	0.9380
0.1	0.3	2.8097	-0.6414	1.0415	-0.1418	1.0842	-0.0312	10060.3234	8920.9060	1777.5758	4.3358	4746.2491	0.5213
0.1	0.5	1.1394	-1.4647	0.5000	-0.1775	-0.1627	-0.0948	237.9649	3864.7675	164.4038	1.5596	1026.4482	0.2585
0.1	0.7	3.3271	0.1468	0.2395	0.1152	1.7370	-0.0082	15718.1083	15.4934	10.2666	2.7677	3933.1623	0.2599
0.1	0.9	1.8838	0.2272	0.5418	0.0126	1.0555	-0.0674	1491.0642	228.2935	116.2753	1.9589	429.7760	0.2844
0.3	0.1	2.8707	-1.1305	5.1518	0.2723	0.8701	0.4333	5284.9159	7533.1344	6598.5107	6.7368	3207.2832	1.2258
0.3	0.3	2.0078	-0.0404	0.8306	0.1836	0.9837	0.1454	574.6469	3064.6533	218.6107	2.3353	910.1927	0.4805
0.3	0.5	1.3783	0.0498	0.0819	0.2190	0.7141	0.1172	277.2464	6.1661	0.5994	1.4043	71.0603	0.2766
0.3	0.7	1.1518	0.0377	0.0474	0.2282	0.5948	0.1396	201.7484	0.1395	0.1212	1.0174	50.6142	0.2345
0.3	0.9	1.8118	0.0442	0.0456	0.2802	0.9280	0.1503	1096.9120	0.1405	0.1359	1.8181	274.5244	0.2764
0.5	0.1	0.4147	0.7348	7.0371	0.2752	0.5748	0.3256	55.2063	2330.6869	27963.3944	1.0256	596.6866	0.5071
0.5	0.3	0.3138	0.1569	0.1802	0.0525	0.2354	0.0497	40.8950	65.4407	10.1117	0.3812	26.5916	0.1791
0.5	0.5	0.4393	0.0450	0.0676	0.0987	0.2422	0.0742	32.7403	0.4846	0.3054	0.3959	8.3608	0.1842
0.5	0.7	0.2224	0.0191	0.0378	0.0836	0.1208	0.0723	2.3698	0.0740	0.0632	0.1555	0.6515	0.0959
0.5	0.9	0.0981	0.0135	0.0175	0.0487	0.0558	0.0469	0.1470	0.0259	0.0258	0.0470	0.0596	0.0427
0.7	0.1	0.1679	0.7071	8.0981	0.2302	0.4375	0.2478	0.3583	226.7925	11200.6660	0.4882	56.8245	0.3064
0.7	0.3	0.0963	0.0671	0.1102	0.0109	0.0817	0.0201	0.1598	0.6401	13.5267	0.1439	0.2011	0.1216
0.7	0.5	0.0688	-0.0244	0.0245	-0.0036	0.0222	-0.0009	0.1102	0.1547	0.0678	0.0828	0.0819	0.0766
0.7	0.7	0.0375	-0.0033	0.0130	0.0136	0.0171	0.0135	0.0339	0.0285	0.0223	0.0236	0.0239	0.0234
0.7	0.9	0.0594	0.0067	0.0137	0.0298	0.0331	0.0294	0.0511	0.0214	0.0208	0.0272	0.0285	0.0267
0.9	0.1	0.1160	0.4909	22.5493	0.1761	0.3035	0.1732	0.1874	267.2856	831308.8534	0.2860	66.8838	0.2202
0.9	0.3	0.0360	-0.0175	0.0312	-0.0279	0.0093	-0.0182	0.0649	0.2490	0.0620	0.1067	0.0947	0.0917
0.9	0.5	0.0071	-0.0207	0.0042	-0.0088	-0.0068	-0.0086	0.0152	0.0270	0.0148	0.0176	0.0173	0.0174
0.9	0.7	0.0067	-0.0143	0.0020	-0.0049	-0.0038	-0.0049	0.0124	0.0173	0.0118	0.0127	0.0127	0.0127
0.9	0.9	0.0068	-0.0013	0.0026	0.0026	0.0028	0.0026	0.0046	0.0045	0.0042	0.0042	0.0043	0.0042

Table 6: Empirical bias and empirical mean squared error of estimators under Beta distribution with $n = 400$

λ_x	λ_y	EB(b_d)	EB(b_i)	EB(b_p)	EB(b_g)	EB(b_m)	EB(b_b)	EM(b_d)	EM(b_i)	EM(b_p)	EM(b_g)	EM(b_m)	EM(b_b)
0.1	0.1	1.3520	0.2701	0.2074	0.1430	0.8111	0.0858	643.1720	74.6640	10.7048	1.0202	179.3010	0.2383
0.1	0.3	1.3764	0.0503	0.0586	0.2002	0.7134	0.0992	463.3403	11.6918	0.2787	1.1657	118.8278	0.1869
0.1	0.5	1.3761	0.0355	0.0336	0.2170	0.7058	0.1169	287.8885	0.0616	0.0532	1.0820	72.0396	0.1676
0.1	0.7	1.2892	0.0208	0.0193	0.2078	0.6550	0.1066	231.2250	0.0388	0.0367	1.0450	57.8913	0.1676
0.1	0.9	1.3790	0.0148	0.0143	0.2152	0.6969	0.1075	349.9436	0.0298	0.0293	1.1352	87.5792	0.1697
0.3	0.1	0.0570	0.1204	0.0340	0.0054	0.0887	0.0119	0.1335	0.7804	0.0783	0.1102	0.2003	0.0900
0.3	0.3	0.0468	0.0097	0.0121	0.0131	0.0283	0.0127	0.0709	0.0555	0.0260	0.0282	0.0306	0.0271
0.3	0.5	0.0498	0.0074	0.0108	0.0206	0.0286	0.0200	0.0577	0.0210	0.0153	0.0198	0.0215	0.0192
0.3	0.7	0.0502	0.0069	0.0087	0.0228	0.0286	0.0221	0.0584	0.0113	0.0104	0.0185	0.0209	0.0176
0.3	0.9	0.0419	0.0051	0.0056	0.0196	0.0235	0.0192	0.0418	0.0067	0.0067	0.0142	0.0154	0.0138
0.5	0.1	0.0220	0.0805	0.0201	-0.0034	0.0513	0.0039	0.0537	0.3604	0.0455	0.0975	0.0976	0.0799
0.5	0.3	0.0101	-0.0067	0.0014	-0.0047	0.0017	-0.0045	0.0192	0.0369	0.0134	0.0155	0.0154	0.0152
0.5	0.5	0.0111	-0.0010	0.0025	0.0026	0.0051	0.0026	0.0129	0.0123	0.0074	0.0075	0.0076	0.0075
0.5	0.7	0.0115	0.0024	0.0038	0.0058	0.0070	0.0058	0.0093	0.0054	0.0045	0.0050	0.0050	0.0050
0.5	0.9	0.0120	0.0021	0.0026	0.0063	0.0071	0.0063	0.0080	0.0033	0.0032	0.0041	0.0042	0.0041
0.7	0.1	0.0142	0.0765	0.0146	-0.0074	0.0454	0.0014	0.0387	0.3675	0.0364	0.1058	0.1018	0.0854
0.7	0.3	0.0071	-0.0091	0.0035	-0.0064	-0.0010	-0.0061	0.0121	0.0387	0.0107	0.0155	0.0152	0.0152
0.7	0.5	0.0000	-0.0026	0.0015	-0.0002	-0.0013	-0.0002	0.0046	0.0070	0.0038	0.0040	0.0041	0.0040
0.7	0.7	0.0000	-0.0006	0.0017	0.0017	-0.0003	0.0017	0.0037	0.0037	0.0027	0.0027	0.0028	0.0027
0.7	0.9	0.0000	0.0011	0.0014	0.0021	0.0006	0.0021	0.0023	0.0016	0.0015	0.0016	0.0016	0.0016
0.9	0.1	0.0123	0.0394	0.0123	-0.0173	0.0259	-0.0077	0.0255	0.2996	0.0252	0.0966	0.0864	0.0787
0.9	0.3	0.0016	-0.0076	0.0012	-0.0063	-0.0030	-0.0061	0.0067	0.0294	0.0066	0.0121	0.0118	0.0119
0.9	0.5	0.0012	-0.0042	0.0006	-0.0023	-0.0015	-0.0023	0.0033	0.0082	0.0033	0.0042	0.0042	0.0042
0.9	0.7	0.0009	-0.0019	0.0003	-0.0007	-0.0005	-0.0007	0.0016	0.0023	0.0015	0.0016	0.0016	0.0016
0.9	0.9	0.0010	-0.0003	0.0003	0.0003	0.0004	0.0003	0.0007	0.0007	0.0006	0.0006	0.0006	0.0006

Table 7: Empirical bias and empirical mean squared error of estimators under Weibull distribution with $n = 40$

λ_x	λ_y	EB(b_d)	EB(b_t)	EB(b_p)	EB(b_g)	EB(b_m)	EB(b_b)	EM(b_d)	EM(b_t)	EM(b_p)	EM(b_g)	EM(b_m)	EM(b_b)
0.1	0.1	-0.8122	3.9127	8.7966	-0.8043	1.5503	0.1442	25.6226	31035.5446	18442.4441	6.8804	7766.3772	1.0942
0.1	0.3	-0.7371	0.2892	3.2244	-0.7178	-0.2240	0.0288	17.0762	11849.4585	2294.5147	1.9348	2967.1073	1.0393
0.1	0.5	-0.7209	-0.1061	1.7567	-0.6664	-0.4135	-0.1577	9.9143	10574.6823	855.5451	0.9675	2646.3800	0.2953
0.1	0.7	-0.6989	-0.6934	0.9913	-0.6270	-0.6962	-0.2531	8.4228	2723.2379	107.3739	0.7076	683.3381	0.2665
0.1	0.9	-0.6905	-0.1297	1.0436	-0.6019	-0.4101	-0.3384	3.6964	1715.6361	859.6314	0.5840	429.9333	0.2511
0.3	0.1	-0.3763	-2.5092	29.2024	-0.2611	-1.4428	0.3942	45.1631	687119.0396	421952.3963	9.0152	171796.7400	1.9657
0.3	0.3	-0.3314	1.0886	3.4926	-0.0158	0.3786	0.0904	33.4634	25961.4080	2905.1746	1.1701	6498.9085	0.3792
0.3	0.5	-0.2589	1.2488	0.9121	-0.1016	0.4950	-0.0540	186.0305	2777.4751	400.3262	0.8307	740.6952	0.1767
0.3	0.7	-0.3030	1.2767	0.9627	-0.1977	0.4869	-0.1408	30.4664	1531.5509	890.6140	0.4564	390.0479	0.1593
0.3	0.9	-0.3457	0.0514	0.2388	-0.2593	-0.1472	-0.2226	15.8133	379.5753	5.2286	0.3256	98.8977	0.1419
0.5	0.1	-0.3205	3.3212	35.9728	0.5246	1.5004	0.5192	0.9836	248088.9276	3100364.3772	4.4997	62023.7518	0.8952
0.5	0.3	-0.3432	1.8725	3.0529	0.2381	0.7647	0.2075	0.5371	9307.0241	4330.2500	0.7016	2326.7145	0.2646
0.5	0.5	-0.3319	1.0640	0.3364	0.0520	0.3661	0.0467	0.3382	54.9207	22.3179	0.1669	13.5842	0.1111
0.5	0.7	-0.3401	0.4311	0.1006	-0.0762	0.0455	-0.0640	0.2504	4.1501	0.3995	0.0899	1.0234	0.0711
0.5	0.9	-0.3629	0.2300	0.1008	-0.1781	-0.0665	-0.1592	1.0595	0.6802	0.3434	0.1344	0.3905	0.0945
0.7	0.1	-0.1990	0.9558	31.2168	0.8961	0.3784	0.6602	0.5273	179084.0967	471185.6583	4.4997	44773.9236	0.9512
0.7	0.3	-0.2911	5.0109	5.9963	0.4825	2.3599	0.3684	0.3724	85978.9099	8540.4828	1.3779	21493.6318	0.3942
0.7	0.5	-0.2344	0.5334	0.1774	0.1867	0.1495	0.1522	0.1538	4973.5203	4.1037	0.1831	1243.5473	0.1204
0.7	0.7	-0.2141	0.3993	0.0430	0.0215	0.0926	0.0192	0.1020	0.4737	0.1101	0.0513	0.0984	0.0456
0.7	0.9	-0.1993	0.1089	0.0253	-0.0665	-0.0452	-0.0642	0.0771	0.0533	0.0348	0.0278	0.0252	0.0264
0.9	0.1	-0.0585	7.8730	128.3777	1.2418	3.9073	0.7973	0.3770	84824.8918	23638686.5236	4.3029	21205.8033	1.1002
0.9	0.3	-0.0688	2.5312	2.2487	0.5983	1.2312	0.4467	0.1252	372.3352	5326.9066	0.7143	92.8393	0.3744
0.9	0.5	-0.0566	0.6524	0.0090	0.2192	0.2979	0.2002	0.0420	0.8881	0.0483	0.1161	0.2118	0.0966
0.9	0.7	-0.0781	0.3857	0.0108	0.1167	0.1538	0.1106	0.0339	0.3105	0.0374	0.0518	0.0750	0.0470
0.9	0.9	-0.0756	0.0913	0.0032	0.0023	0.0079	0.0023	0.0179	0.0269	0.0132	0.0108	0.0111	0.0107

Table 8: Empirical bias and empirical mean squared error of estimators under Weibull distribution with $n = 400$

λ_x	λ_y	EB(b_d)	EB(b_i)	EB(b_p)	EB(b_g)	EB(b_m)	EB(b_b)	EM(b_d)	EM(b_i)	EM(b_p)	EM(b_g)	EM(b_m)	EM(b_b)
0.1	0.1	-0.8864	12.4597	6.0750	-0.2405	5.7867	0.0018	0.7969	263189.7613	15841.6610	0.5658	65791.8951	0.0032
0.1	0.3	-0.8763	2.8304	0.5789	-0.4109	0.9771	-0.1834	0.7719	1202.6556	66.3332	0.1922	299.5651	0.0416
0.1	0.5	-0.8792	1.1264	0.1872	-0.5304	0.1236	-0.3111	0.7755	77.6619	5.8955	0.2877	19.0993	0.1046
0.1	0.7	-0.8958	0.6251	0.1433	-0.6152	-0.1354	-0.3989	0.8040	4.9867	1.0687	0.3820	1.1588	0.1666
0.1	0.9	-0.8879	0.1761	0.0648	-0.6497	-0.3559	-0.4793	0.7897	0.2064	0.1466	0.4244	0.1674	0.2340
0.3	0.1	-0.6438	9.8753	1.1512	0.6809	4.6158	0.2433	0.4418	19719.6941	2832.6520	0.6230	4926.4105	0.0798
0.3	0.3	-0.6935	2.8016	0.1440	0.0123	1.0541	0.0042	0.4918	37.5530	0.4694	0.0232	8.4808	0.0074
0.3	0.5	-0.6749	1.0020	0.0398	-0.2111	0.1636	-0.1524	0.4626	1.2511	0.1025	0.0552	0.0814	0.0294
0.3	0.7	-0.6722	0.4253	0.0212	-0.3254	-0.1235	-0.2645	0.4575	0.2394	0.0379	0.1120	0.0283	0.0742
0.3	0.9	-0.6622	0.1112	0.0120	-0.3923	-0.2755	-0.3444	0.4434	0.0298	0.0152	0.1581	0.0806	0.1216
0.5	0.1	-0.4683	9.7818	0.5429	1.1903	4.6568	0.4665	0.2578	584.6675	347.8373	1.5564	143.5431	0.2567
0.5	0.3	-0.5004	2.5788	0.0607	0.3019	1.0392	0.1883	0.2649	7.8801	0.1404	0.1212	1.3595	0.0477
0.5	0.5	-0.4546	0.8969	0.0233	0.0075	0.2212	0.0055	0.2156	0.9178	0.0424	0.0115	0.0754	0.0080
0.5	0.7	-0.4878	0.4375	0.0113	-0.1472	-0.0252	-0.1301	0.2449	0.2261	0.0224	0.0282	0.0097	0.0220
0.5	0.9	-0.4699	0.1079	0.0053	-0.2363	-0.1810	-0.2222	0.2264	0.0200	0.0073	0.0596	0.0362	0.0525
0.7	0.1	-0.2977	10.4927	0.1674	1.6654	5.0975	0.7015	0.1345	204.1324	98.5231	2.9239	49.0966	0.5492
0.7	0.3	-0.2869	2.3044	0.0164	0.5143	1.0088	0.3740	0.0962	5.9311	0.0411	0.2959	1.1603	0.1549
0.7	0.5	-0.2788	0.9416	0.0109	0.1766	0.3314	0.1538	0.0856	0.9825	0.0209	0.0432	0.1339	0.0325
0.7	0.7	-0.3071	0.1216	0.0035	-0.1198	-0.0928	-0.1163	0.0987	0.0200	0.0044	0.0171	0.0113	0.0161
0.7	0.9	-0.0866	8.5121	0.0050	1.8540	4.2128	0.9472	0.0483	84.4480	0.0505	3.5807	20.5557	0.9512
0.9	0.1	-0.1023	2.4765	0.0026	0.7487	1.1871	0.5767	0.0235	6.7334	0.0171	0.5968	1.5491	0.3495
0.9	0.3	-0.1049	1.0732	0.0016	0.3565	0.4842	0.3211	0.0173	1.2541	0.0087	0.1405	0.2605	0.1128
0.9	0.5	-0.0894	0.3841	0.0011	0.1214	0.1474	0.1182	0.0107	0.1620	0.0036	0.0187	0.0266	0.0177
0.9	0.7	-0.1024	0.1155	0.0005	0.0004	0.0066	0.0003	0.0120	0.0157	0.0017	0.0013	0.0014	0.0013
0.9	0.9	-0.1037	0.1179	0.0009	0.0007	0.0071	0.0007	0.0123	0.0164	0.0017	0.0014	0.0015	0.0014