

Malakhov, Alexey; Vohra, Rakesh V.

Working Paper

Single and multi-dimensional optimal auctions: a network approach

Discussion Paper, No. 1397

Provided in Cooperation with:

Kellogg School of Management - Center for Mathematical Studies in Economics and Management Science, Northwestern University

Suggested Citation: Malakhov, Alexey; Vohra, Rakesh V. (2004) : Single and multi-dimensional optimal auctions: a network approach, Discussion Paper, No. 1397, Northwestern University, Kellogg School of Management, Center for Mathematical Studies in Economics and Management Science, Evanston, IL

This Version is available at:

<https://hdl.handle.net/10419/31166>

Standard-Nutzungsbedingungen:

Die Dokumente auf EconStor dürfen zu eigenen wissenschaftlichen Zwecken und zum Privatgebrauch gespeichert und kopiert werden.

Sie dürfen die Dokumente nicht für öffentliche oder kommerzielle Zwecke vervielfältigen, öffentlich ausstellen, öffentlich zugänglich machen, vertreiben oder anderweitig nutzen.

Sofern die Verfasser die Dokumente unter Open-Content-Lizenzen (insbesondere CC-Lizenzen) zur Verfügung gestellt haben sollten, gelten abweichend von diesen Nutzungsbedingungen die in der dort genannten Lizenz gewährten Nutzungsrechte.

Terms of use:

Documents in EconStor may be saved and copied for your personal and scholarly purposes.

You are not to copy documents for public or commercial purposes, to exhibit the documents publicly, to make them publicly available on the internet, or to distribute or otherwise use the documents in public.

If the documents have been made available under an Open Content Licence (especially Creative Commons Licences), you may exercise further usage rights as specified in the indicated licence.

Single and Multi-Dimensional Optimal Auctions - A Network Approach*

Alexey Malakhov and Rakesh V. Vohra

Department of Managerial Economics and Decision Sciences
Kellogg School of Management
Northwestern University
Evanston IL 60208, USA

December 2004

Abstract

This paper highlights connections between the discrete and continuous approaches to optimal auction design with single and multi-dimensional types. We provide an interpretation of an optimal auction design problem in terms of a linear program that is an instance of a parametric shortest path problem on a lattice. We also solve some cases explicitly in the discrete framework.

JEL Classification: C61, C70, D44

Keywords: Auctions, Networks, Linear Programming

*The research was supported in part by the NSF grant ITR IIS-0121678.

1 Introduction

The problem of identifying an auction design that maximizes the auctioneers expected revenue (optimal auction) is in general difficult (see for example Ronen and Saberi (2002)). An obvious difficulty is the fact that there are a multiplicity of parameters to play with. For example, should payment depend on the bidders identity? Should one employ a reserve price? Should one subsidize some bidders? Does it pay to screen bidders before hand? There are a multitude of design parameters to set. It is not clear how one searches through all these parameters to find the setting that best achieves them.

Under the assumption of independent private values, the revelation principle of Myerson (1981) allows one, without loss of generality, to restrict attention to direct revelation mechanisms. When the types of agents were continuous and one-dimensional Myerson used the revelation principle to determine the optimal auction. Myerson's (1981) approach has become a staple in the auction design literature. However, the approach cannot be easily extended to deal with multi-dimensional types (see the review by Rochet and Stole (2003)).

Most efforts for solving the optimal auction problem with multi-dimensional types have assumed a continuous type space. In this paper we study auctions with multi-dimensional types that are discrete. This has the advantage of transparency of analysis, and it also allows us to approach the problem from an intuitive network perspective. We interpret optimal auction payments as being determined by shortest paths on a network representing bidders types. This approach highlights the connections between optimal mechanism design and the problem of finding a shortest path in a lattice, as well as linear programming. It clarifies the nature of the difficulties inherent in the multi-dimensional optimal auction design problem, and makes clear which cases are solvable and which are not.

This paper offers a comparison between the optimal auction problem with continuous types and with discrete types. We will examine the optimal auction problem in one and multi-dimensional settings, providing a network interpretation of existing results, such as Myerson's (1981) one-dimensional optimal auction design problem, and Wilson's (1993) problem of a monopolist facing consumers with two-dimensional types. Our approach also provides a new result for a particular case when types are two-dimensional.

The paper is organized as follows. The next section provides a general setup and describes a motivating example. Section 3 is devoted to the case of one-dimensional types and its connection to Myerson (1981). In this section we give a new perspective on the ironing procedure. A general

analysis of multi-dimensional optimal auctions is provided in Section 4. Analyses of particular solvable cases are performed in Sections 5 and 6. Section 7 concludes.

2 Setup and Motivating Example

Following Myerson we invoke the revelation principle. The model and notation used are described below.

1. Agents and auctioneer are risk neutral.
2. \mathcal{F} is the set of feasible allocations of the resources amongst the agents and the auctioneer.
3. $T = \{t_1, t_2, \dots, t_m\}$ is a finite set of an agent's types (possibly multi-dimensional). A collection of types one for each (of n agents) will be called a profile t . Let T^n be the set of all profiles. A profile involving only $n - 1$ agents will be denoted t^{n-1} .
4. If $a \in \mathcal{F}$ and a bidder has type t_i she assigns monetary value $v(a|t_i)$ to the allocation $a \in \mathcal{F}$.
5. Uncertainty about how the valuations of the bidders is captured assuming that types are independent draws from a common distribution that is commonly known. This is the common prior assumption. Let f_i be the probability that a bidder has type t_i .
6. The probability of a profile $t^{n-1} \in T^{n-1}$ being realized is $\pi(t^{n-1})$.

One could easily include costs for the seller into the setup, but it changes nothing essential in the arguments and clutters the notation. In a departure from the auction theory literature we assume a discrete type space.

By the revelation principle we can restrict attention to direct revelation mechanisms. Each agent is asked to announce her type. The auctioneer, as a function of the announcements, decides what element of \mathcal{F} to pick and what payments each agent will make.

Let P_i be the expected payment that an agent who announces type t_i must make. An allocation rule assigns to each member of T^n an element of \mathcal{F} .¹ If \mathbf{a} is an allocation rule, write $\mathbf{a}_i(t)$ to denote the the allocation to a type t_i under profile t . The expected utility of an agent with type t_i under

¹Strictly speaking one should allow an allocation rule to be randomized. Given risk neutrality, we omit this possibility. To account for it requires introducing additional notation that is subsequently not used.

this rule will be (under the assumption that agents announce truthfully)

$$E_{t^{n-1}}[v(\mathbf{a}_i[t_i, t^{n-1}]|t_i)] = \sum_{t^{n-1} \in T^{n-1}} v(\mathbf{a}_i[t_i, t^{n-1}]|t_i)\pi(t^{n-1}).$$

The expected utility of agent with type t_i announcing t_j ($\neq t_i$) under allocation rule \mathbf{A} is

$$E_{t^{n-1}}[v(\mathbf{a}_j[t_j, t^{n-1}]|t_i)] = \sum_{t^{n-1} \in T^{n-1}} v(\mathbf{a}_j[t_j, t^{n-1}]|t_i)\pi(t^{n-1}).$$

To ensure that an agent will report truthfully we impose (Bayesian) incentive compatibility (IC): for each agent with type t_i :

$$E_{t^{n-1}}[v(\mathbf{a}_i[t_i, t^{n-1}]|t_i)] - P_i \geq E_{t^{n-1}}[v(\mathbf{a}_j[t_j, t^{n-1}]|t_i)] - P_j \quad \forall t_i, t_j \in T.$$

To ensure that each agent has the incentive to participate we impose the individual rationality (IR) constraint:

$$E_{t^{n-1}}[v(\mathbf{a}_i[t_i, t^{n-1}]|t_i)] - P_i \geq 0 \quad \forall t_i \in T.$$

If we add a dummy type, t_0 which assigns utility 0 to all allocations, and set $P_0 = 0$, we can fold the IR constraint into the IC constraint.² So, from now on T contains the dummy type t_0 .

The auctioneer's problem is to maximize expected revenue subject to IC. Expected revenue (normalized for population) is $\sum_{i=0}^m f_i P_i$. Fix an allocation rule \mathbf{a} and let

$$R(\mathbf{a}) = \max_{P_i} \sum_{i=0}^m f_i P_i$$

$$\text{s.t. } E_{t^{n-1}}[v(\mathbf{a}_i[t_i, t^{n-1}]|t_i)] - P_i \geq E_{t^{n-1}}[v(\mathbf{a}_j[t_j, t^{n-1}]|t_i)] - P_j \quad \forall t_i, t_j \in T.$$

Call this program $LP_{\mathbf{a}}$. If $LP_{\mathbf{a}}$ is infeasible set $R(\mathbf{a}) = -\infty$. Thus the auctioneer's problem is to find the allocation rule \mathbf{a} that maximizes $R(\mathbf{a})$.

One way to solve this optimization problem is to fix the allocation rule \mathbf{a} . Then we can rewrite the IC constraint as follows:

$$P_i - P_j \leq E_{t^{n-1}}[v(\mathbf{a}_i[t_i, t^{n-1}]|t_i)] - E_{t^{n-1}}[v(\mathbf{a}_j[t_j, t^{n-1}]|t_i)] \quad \forall i \neq j.$$

If there is a feasible solution to this system of inequalities then we can find payments that implement \mathbf{a} in an incentive compatible way.

²It is sometimes common to require that the *actual* payoff be non-negative rather than the expected payoff as we have done here. This stronger condition is called ex-post individual rationality.

To understand this inequality system it helps to flip to its dual. The dual is a network flow problem that can be described in the following way. Introduce one node for each type (the node corresponding to the dummy type will be the source) and to each directed edge (j, i) , assign a length of $E_{t^{n-1}}[v(\mathbf{a}_i[t_i, t^{n-1}]|t_i)] - E_{t^{n-1}}[v(\mathbf{a}_j[t_j, t^{n-1}]|t_i)]$. Each P_i corresponds to the length of the shortest path from the source to vertex i . For fixed \mathbf{a} , the optimization problem reduces to determining the shortest path tree in this network (union of all shortest paths from source to all nodes).³

2.1 Motivating Example

Consider the allocation of one good among two agents with types $\{0, 1, 2\}$, here 0 is the dummy type. Let $f_1 = f_2 = 1/2$ and $\pi(1) = \pi(2) = 1/2$ be the probabilities. Choose as the allocation rule the following: assign the object to the agent with highest type, in case of ties randomize the allocation ‘50-50’. The possible allocations are: agent 1 wins, agent 2 wins, agent 1 and 2 get 1/2 of the item, seller keeps it. For the valuations we have: an agent of type t_i who wins the item values it at t_i ; if he tied with his competitor and gets only a half he derives value $t_i/2$ if finally he loses or the seller keeps it, he gets value 0. Now to the computation of expected utility when honest. If $t_1 = 1$ then

$$E_{t^{n-1}}[v(\alpha[t_i, t^{n-1}]|t_i)] = \sum_{t^1 \in \{0, 1, 2\}} v(\alpha[t_i, t^1]|t_i)\pi(t^1) = \frac{1}{4},$$

and is equal to $\frac{3}{2}$ if $t_i = 2$.

Similarly we obtain for $E_{t^{n-1}}[v(\alpha[t, t^{n-1}]|t_i)]$:

$t_i \setminus t_j$	0	1	2
0	0	0	0
1	0	$\frac{1}{4}$	$\frac{3}{4}$
2	0	$\frac{1}{2}$	$\frac{3}{2}$

So we obtain for the optimization problem

$$\begin{aligned} \max \quad & \frac{1}{2}P_1 + \frac{1}{2}P_2 \\ \text{s.t.} \quad & P_1 - P_0 \leq \frac{1}{4}, \quad P_0 - P_1 \leq 0, \quad P_0 - P_2 \leq 0, \\ & P_2 - P_0 \leq \frac{3}{2}, \quad P_2 - P_1 \leq 1, \quad P_1 - P_2 \leq -\frac{1}{2}, \\ & P_0 = 0. \end{aligned}$$

³The reader unfamiliar with Network Flows may consult Ahuja, Maganati and Orlin (1993).

The resulting shortest path problem is depicted dashed in figure 1. Reading off the shortest path distances to t_1, t_2 yields $P_1 = 1/4$ and $P_2 = 5/4$. So the auctioneer can realize revenue of $3/4$ with this allocation rule.

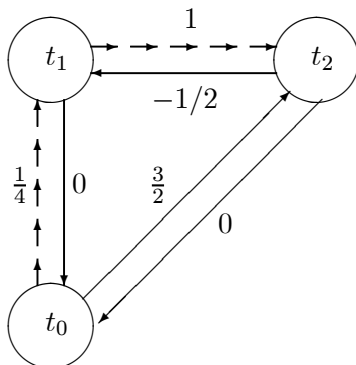

Figure 1

If the network has a negative cycle, the dual problem is unbounded, which means the original primal problem is infeasible. Thus, there is no set of payments to make the allocation \mathbf{a} incentive compatible. To summarize, given an allocation rule we have a way of checking whether it can be implemented in an incentive compatible way.

Naively, one could fix an allocation rule \mathbf{a} , then solve the inequality system and repeat. The problem is that the set of allocation rules need not be finite or even countable! Thus, unless one is prepared to make additional assumptions about the structure of the problem, the optimal auction will be difficult to identify. The rest of the paper is dedicated to solving the optimal auction problem in one and multi-dimensional settings from the point of view that auction payments are determined by shortest paths through a network representing agents' types.

3 The One Good (Multi-Unit) Case

We consider first the case of a seller with K units of an indivisible good who is selling it to n buyers with constant marginal valuations. The marginal valuations are private information.⁴

If \mathbf{a} is an allocation rule, write \mathcal{A}_i to be the (expected) quantity of the good that an agent with type t_i receives. The approach taken is to identify inequalities that the \mathcal{A}_i 's must satisfy. This will yield a relaxation of the underlying optimization problem with the \mathcal{A}_i 's as decision variables. Subsequently we identify an allocation rule that will generate the expected allocations identified in the solution to the relaxation.

⁴This case is discussed in Rochet and Stole (2003).

IC implies:

$$v(\mathcal{A}_i|i) - P_i \geq v(\mathcal{A}_j|i) - P_j.$$

We associate a network with this collection of IC constraints. Introduce a vertex i for each type i . Between every ordered pair of vertices (j, i) a directed edge of length $v(\mathcal{A}_i|i) - v(\mathcal{A}_j|i)$. The allocation rule will be incentive compatible iff. this network has no negative length cycle. if this network has no negative length cycles we can choose the P_i 's to be the length of the path from an arbitrarily chosen root vertex, r , to vertex i in the shortest path tree rooted at r . If in addition we want the IR constraint to hold, we would choose the root, r to be the vertex corresponding to the dummy type t_0 .

Assuming \mathbf{a} is incentive compatible, the cycle $i \rightarrow j \rightarrow i$ must have non-negative length. This observation gives us our first result.

Theorem 1 *An allocation rule that is incentive compatible must be monotonic. That is if $r \leq s$ then $\mathcal{A}_r \leq \mathcal{A}_s$.*

Proof. Suppose $r \leq s$ but $\mathcal{A}_r > \mathcal{A}_s$. Then, incentive compatibility implies that

$$v(\mathcal{A}_r|r) - v(\mathcal{A}_s|r) \geq P_r - P_s.$$

Increasing differences implies that

$$v(\mathcal{A}_r|r) - v(\mathcal{A}_s|r) \leq v(\mathcal{A}_r|s) - v(\mathcal{A}_s|s).$$

Hence

$$v(\mathcal{A}_r|s) - v(\mathcal{A}_s|s) \geq P_r - P_s,$$

i.e. $v(\mathcal{A}_r|s) - P_r \geq v(\mathcal{A}_s|s) - P_s$, violating incentive compatibility. ■

If $i \geq j$ we refer to

$$v(\mathcal{A}_i|i) - P_i \geq v(\mathcal{A}_j|i) - P_j$$

as a downward IC constraint. If $i < j$ it is called an upward IC constraint. Next we show that ‘adjacent’ IC constraints suffice. This also follows from the absence of negative cycles. If the network has no negative length cycles, then the length of the edge from i to $i + 2$ must be at least as large as the length of $(i, i + 1)$ plus the length of $(i + 1, i + 2)$.

Theorem 2 *Suppose that v satisfies increasing differences. All IC constraints are implied by the following:*

$$v(\mathcal{A}_i|i) - P_i \geq v(\mathcal{A}_{i-1}|i) - P_{i-1} \quad \forall i = 1, \dots, m \quad (\text{IC}_i^d)$$

$$v(\mathcal{A}_i|i) - P_i \geq v(\mathcal{A}_{i+1}|i) - P_{i+1} \quad \forall i = 1, \dots, m-1 \quad (\text{IC}_i^u)$$

Proof. To show why only the adjacent downward IC constraints are sufficient, we show that the following pair of inequalities:

$$v(\mathcal{A}_i|i) - P_i \geq v(\mathcal{A}_{i-1}|i) - P_{i-1}$$

$$v(\mathcal{A}_{i-1}|i-1) - P_{i-1} \geq v(\mathcal{A}_{i-2}|i-1) - P_{i-2}$$

imply $v(\mathcal{A}_i|i) - P_i \geq v(\mathcal{A}_{i-2}|i) - P_{i-2}$. The rest will follow by induction.

Adding the given pair of inequalities yields:

$$v(\mathcal{A}_i|i) - P_i + v(\mathcal{A}_{i-1}|i-1) \geq v(\mathcal{A}_{i-1}|i) + v(\mathcal{A}_{i-2}|i-1) - P_{i-2}.$$

Rearranging this:

$$v(\mathcal{A}_i|i) - P_i \geq [v(\mathcal{A}_{i-1}|i) - v(\mathcal{A}_{i-2}|i)] - [v(\mathcal{A}_{i-1}|i-1) - v(\mathcal{A}_{i-2}|i-1)] + v(\mathcal{A}_{i-2}|i) - P_{i-2}.$$

By increasing differences and monotonicity of the allocation rule:

$$[v(\mathcal{A}_{i-1}|i) - v(\mathcal{A}_{i-2}|i)] - [v(\mathcal{A}_{i-1}|i-1) - v(\mathcal{A}_{i-2}|i-1)] \geq 0,$$

and this yields

$$v(\mathcal{A}_i|i) - P_i \geq v(\mathcal{A}_{i-2}|i) - P_{i-2}.$$

Almost identical argument show that only the adjacent upward IC constraints are sufficient.

This follows from the fact that the following pair of inequalities:

$$v(\mathcal{A}_{i+1}|i) - v(\mathcal{A}_i|i) \leq P_{i+1} - P_i$$

$$v(\mathcal{A}_{i+2}|i+1) - v(\mathcal{A}_{i+1}|i+1) \leq P_{i+2} - P_{i+1}$$

when added together imply that

$$v(\mathcal{A}_{i+2}|i) - v(\mathcal{A}_i|i) + [v(\mathcal{A}_{i+2}|i+1) - v(\mathcal{A}_{i+1}|i+1)] - [v(\mathcal{A}_{i+2}|i) - v(\mathcal{A}_{i+1}|i)] \leq P_{i+2} - P_i,$$

and hence by increasing differences and monotonicity of the allocation rule:

$$v(\mathcal{A}_{i+2}|i) - v(\mathcal{A}_i|i) \leq P_{i+2} - P_i$$

The rest follows by induction. ■

In view of the above, our network can be depicted as shown in figure 2.

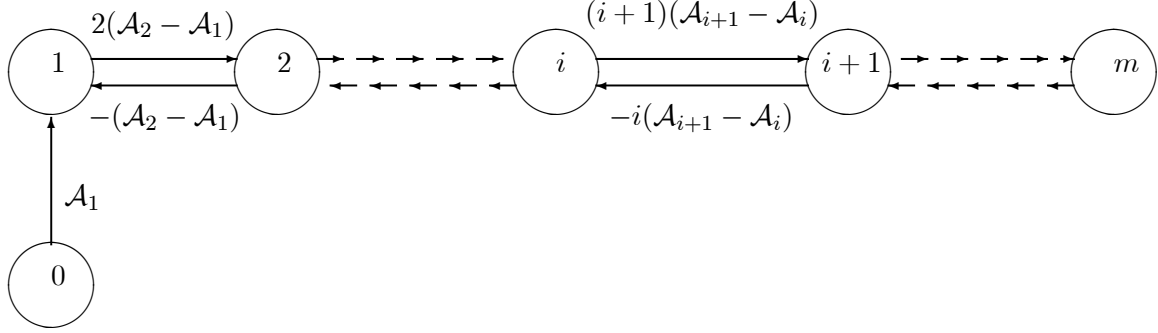

Figure 2

Notice that this network has no negative length cycles if and only if all the cycles on adjacent pairs of vertices are non-negative. Specifically,

$$v(\mathcal{A}_i|i) - v(\mathcal{A}_{i-1}|i) + v(\mathcal{A}_{i-1}|i-1) - v(\mathcal{A}_i|i-1) \geq 0$$

implies that

$$v(\mathcal{A}_i|i) - v(\mathcal{A}_j|i) \geq v(\mathcal{A}_i|i-1) - v(\mathcal{A}_{i-1}|i-1).$$

By increasing differences, this last inequality can hold only if $\mathcal{A}_i \geq \mathcal{A}_{i-1}$. That is, the allocation rule must be monotonic. We thus conclude that \mathbf{a} is incentive compatible if and only if \mathbf{a} is monotonic.

Suppose now that \mathbf{a} is incentive compatible. We know that the our network of figure 2 has no negative length cycles. It is easy to see that the shortest path tree rooted at dummy vertex ‘0’ must be $0 \rightarrow 1 \rightarrow 2 \rightarrow \dots \rightarrow m$. Algebraically, we have set $\mathcal{A}_0 = 0$, and $P_0 = 0$ for the dummy type and

$$P_i = \sum_{r=1}^i [v(\mathcal{A}_r|r) - v(\mathcal{A}_{r-1}|r)]. \quad (1)$$

Notice that $P_i - P_{i-1} = v(\mathcal{A}_i|i) - v(\mathcal{A}_{i-1}|i)$ for the above expected payment schedule, hence all downward IC constraints are satisfied and bind, i.e.

$$v(\mathcal{A}_i|i) - P_i = v(\mathcal{A}_{i-1}|i) - P_{i-1} \quad \forall i = 1, \dots, m.$$

It is easy to see that the upward IC constraints all hold, but for completeness we provide the argument.

Lemma 1 *If either the downward constraint (IC_i^d) or the upward constraint (IC_{i-1}^u) binds, then the other one is satisfied.*

Proof. If the downward adjacent IC_i^d constraint binds, then

$$v(\mathcal{A}_i|i) - v(\mathcal{A}_{i-1}|i) = P_i - P_{i-1}.$$

Then by increasing differences and monotonicity of the allocation rule:

$$v(\mathcal{A}_i|i-1) - v(\mathcal{A}_{i-1}|i-1) \leq P_i - P_{i-1},$$

which means that the corresponding upward constraint IC_{i-1}^u is satisfied.

If the upward adjacent IC_{i-1}^u constraint binds, then

$$v(\mathcal{A}_i|i-1) - v(\mathcal{A}_{i-1}|i-1) = P_i - P_{i-1}.$$

Then by increasing differences and monotonicity of the allocation rule:

$$v(\mathcal{A}_i|i) - v(\mathcal{A}_{i-1}|i) \geq P_i - P_{i-1},$$

which means that the corresponding downward constraint IC_i^d is satisfied. ■

We now summarize our conclusions.

Theorem 3 *For any monotonic allocation rule \mathbf{a} there exists an expected payment schedule $\{P_i\}_{i=0}^m$, such that all the adjacent IC constraints are satisfied.*

Proof. Set $\mathcal{A}_r = 0$, and $P_0 = 0$ for the dummy type. Then set

$$P_i = \sum_{r=1}^i [v(\mathcal{A}_r|r) - v(\mathcal{A}_{r-1}|r)].$$

Notice that $P_i - P_{i-1} = v(\mathcal{A}_i|i) - v(\mathcal{A}_{i-1}|i)$ for the above expected payment schedule $\{P_i\}_{i=0}^m$, hence all (IC^d) are satisfied and bind, i.e.

$$v(\mathcal{A}_i|i) - P_i = v(\mathcal{A}_{i-1}|i) - P_{i-1} \quad \forall i = 1, \dots, m.$$

Hence Lemma 1 gives us that all (IC^u) are satisfied, and thus by Theorem 2 the allocation rule \mathbf{a} is incentive compatible. ■

3.1 A Formulation

If \mathbf{a} is the allocation rule and t a profile of types denote by $\mathbf{a}_i(t)$ the allocation to a type t_i . Then

$$\mathcal{A}_i = \sum_{t^{n-1} \in T^{n-1}} \mathbf{a}_i[t_i, t^{n-1}] \pi(t^{n-1}).$$

Let $n_i(t)$ be the number of agents with type t_i . The problem of finding the optimal auction can be formulated as:

$$Z_1 = \max_{\{\mathbf{a}\}} \sum_{i=0}^m n f_i P_i \quad (OPT1)$$

$$\text{s.t. } v(\mathcal{A}_i|i) - P_i \geq v(\mathcal{A}_{i-1}|i) - P_{i-1} \quad \forall i = 1, \dots, m \quad (IC_i^d)$$

$$v(\mathcal{A}_i|i) - P_i \geq v(\mathcal{A}_{i+1}|i) - P_{i+1} \quad \forall i = 1, \dots, m-1 \quad (IC_i^u)$$

$$0 \leq \mathcal{A}_1 \leq \dots \leq \mathcal{A}_i \leq \dots \leq \mathcal{A}_m \quad (M)$$

$$\mathcal{A}_i = \sum_{t^{n-1} \in T^{n-1}} \mathbf{a}_i[t_i, t^{n-1}] \pi(t^{n-1}) \quad (A)$$

$$\sum_i n_i(t) \mathbf{a}_i[t_i, t^{n-1}] \leq K \quad \forall t \in T^n \quad (C)$$

An upper bound on each P_i is the length of the shortest path from the dummy node ‘0’ to vertex i in the network of figure 2. This is proved formally below.

Lemma 2 *All downward constraints (IC_i^d) bind in a solution to the $[OPT1]$ problem.*

Proof. First, notice that at an optimal solution of the $[OPT1]$ problem either (IC_i^d) or (IC_{i-1}^u) must bind for $\forall i$, since otherwise we can either increase payments, or reduce allocations, thus achieving more revenue. If (IC_i^d) binds, it gives

$$P_i^d = v(\mathcal{A}_i|i) - v(\mathcal{A}_{i-1}|i) + P_{i-1}. \quad (P^d)$$

Binding (IC_{i-1}^u) gives

$$P_i^u = v(\mathcal{A}_i|i-1) - v(\mathcal{A}_{i-1}|i-1) + P_{i-1}. \quad (P^u)$$

then increasing differences and monotonicity of the allocation rule imply $P_i^d \geq P_i^u$, i.e. that higher revenue is achieved with (IC_i^d) constraints binding. ■

The essence of the previous result is that once the allocation rule is chosen, equation (1) pins down the payments necessary to ensure incentive compatibility. Our problem reduces to finding the optimal allocation rule.

Given equation (1), $Z_1 = \sum_{i=1}^m n f_i \sum_{r=1}^i [v(\mathcal{A}_r|r) - v(\mathcal{A}_{r-1}|r)]$. Write $F(i) = \sum_{r=1}^i f_r$ then $F(m) = 1$. Then

$$Z_1 = \sum_{i=1}^m n \{ f_i v(\mathcal{A}_i|i) + (1 - F(i)) [v(\mathcal{A}_i|i) - v(\mathcal{A}_i|i+1)] \}.$$

We interpret $v(\mathcal{A}_i|m+1)$ to be zero.

Let

$$\mu(\mathcal{A}_i) = v(\mathcal{A}_i|i) - \frac{1 - F(i)}{f_i} [v(\mathcal{A}_i|i+1) - v(\mathcal{A}_i|i)].$$

The function μ is what Myerson calls the virtual valuation.

Problem [OPT1] becomes

$$\begin{aligned} Z_1 &= \max_{\{\mathbf{a}\}} \sum_{i=1}^m n f_i \mu(\mathcal{A}_i) \\ \text{s.t. } &0 \leq \mathcal{A}_1 \leq \dots \leq \mathcal{A}_i \leq \dots \leq \mathcal{A}_m \\ \mathcal{A}_i &= \sum_{t^{n-1} \in T^{n-1}} \mathbf{a}_i[t_i, t^{n-1}] \pi(t^{n-1}) \\ \sum_i n_i(t) \mathbf{a}_i[t_i, t^{n-1}] &\leq K \quad \forall t \in T^n \end{aligned}$$

3.2 The Myerson Case

Myerson (1981) makes the following additional assumptions:

1. $v(q|i) = iq$, and
2. $\frac{1-F(i)}{f_i}$ is non-decreasing in i .

This second assumption is the monotone hazard condition. With these additional assumptions $\mu(\mathcal{A}_i) = \mathcal{A}_i \left(i - \frac{1-F(i)}{f_i} \right)$. Then

$$\begin{aligned} Z_1 &= \max_{\{\mathbf{a}\}} \sum_{i=1}^m f_i \mathcal{A}_i \left(i - \frac{1-F(i)}{f_i} \right) \\ \text{s.t. } &0 \leq \mathcal{A}_1 \leq \dots \leq \mathcal{A}_i \leq \dots \leq \mathcal{A}_m \\ \mathcal{A}_i &= \sum_{t^{n-1} \in T^{n-1}} \mathbf{a}_i[t_i, t^{n-1}] \pi(t^{n-1}) \\ \sum_i n_i(t) \mathbf{a}_i[t_i, t^{n-1}] &\leq K \quad \forall t \in T^n \end{aligned}$$

We can rewrite this program to read:

$$\begin{aligned} &\max_{\{\mathbf{a}\}} \sum_i \sum_{t^{n-1} \in T^{n-1}} n f_i \mathbf{a}_i[t_i, t^{n-1}] \left(i + \frac{1-F(i)}{f_i} \right) \pi(t^{n-1}) \\ \text{s.t. } &0 \leq \sum_{t^{n-1} \in T^{n-1}} \mathbf{a}_1[t_1, t^{n-1}] \pi(t^{n-1}) \leq \dots \leq \sum_{t^{n-1} \in T^{n-1}} \mathbf{a}_m[t_m, t^{n-1}] \pi(t^{n-1}) \leq K \\ &\sum_i n_i(t) \mathbf{a}_i[t_i, t^{n-1}] \leq K \quad \forall t \in T^n \end{aligned}$$

If we ignore the monotonicity constraints, this problem can be decomposed into $|T^n|$ subproblems one for each profile of types:

$$\begin{aligned} \max_{\{\mathbf{a}\}} \sum_i n_i(t) \left(i - \frac{1 - F(i)}{f_i} \right) \mathbf{a}_i(t) \\ \text{s.t. } \sum_i n_i(t) \mathbf{a}_i(t) \leq K \end{aligned}$$

This is an instance of a continuous knapsack problem. Its solution well known. Select any index $r \in \arg \max_{i: n_i(t) > 0} \left\{ \frac{n_i(t)(i - \frac{1 - F(i)})}{n_i(t) f_i} \right\}$ and set $a_r(t) = K/n_r(t)$. The monotone hazard condition ensures that the largest index is always chosen. Thus the solution to the program is monotonic, i.e. $\mathbf{a}_{i+1}(t) \geq \mathbf{a}_i(t)$ for all i and profiles t . It follows from this that the ignored monotonicity constraints on expected allocations are satisfied.

The above analysis naturally yields the revenue equivalence result of auction theory.

Theorem 4 *All incentive compatible allocation rules that result in the same equilibrium expected allocation schedule $\{\mathcal{A}_i\}_{i=0}^m$ generate the same expected revenue for the seller.*

Proof. Recall that the expected payment P_i is determined through the length of the shortest path from the dummy node ‘0’ to vertex i in the network, and is given by (1) as

$$P_i = \sum_{r=1}^i [r \mathcal{A}_r - r \mathcal{A}_{r-1}].$$

Notice that the length of the shortest path and hence the expected payment is uniquely defined by the equilibrium expected allocations $\{\mathcal{A}_i\}_{i=0}^m$. Therefore we conclude that all incentive compatible allocation rules that result in the same equilibrium expected allocation schedule $\{\mathcal{A}_i\}_{i=0}^m$ generate the same expected payments $\{P_i\}_{i=1}^m$, and hence the same expected revenue for the seller. ■

The monotonicity constraints are useful because they allow us to restrict the space of possible allocation rules. However, their presence prevents us from decomposing the optimization problem into separate problems over profiles. The hazard rate condition is one sufficient condition for such a decomposition to be possible.

3.3 Ironing

Here we discuss how to solve problem when the monotone hazard condition does not hold. Recall that our problem is

$$Z = \max_{\{\mathbf{a}\}} \sum_i \sum_{t^{n-1} \in T^{n-1}} n f_i \mathbf{a}_i[t_i, t^{n-1}] \left(i + \frac{1 - F(i)}{f_i} \right) \pi(t^{n-1})$$

$$\begin{aligned} \text{s.t. } \quad & \sum_{t^{n-1} \in T^{n-1}} \mathbf{a}_i[t_i, t^{n-1}] \pi(t^{n-1}) - \sum_{t^{n-1} \in T^{n-1}} \mathbf{a}_{i+1}[t_{i+1}, t^{n-1}] \pi(t^{n-1}) \leq 0 \quad \forall i = 0, \dots, m-1 \\ & \sum_i n_i(t) \mathbf{a}_i[t_i, t^{n-1}] \leq K \quad \forall t \in T^n \end{aligned}$$

Here we interpret $a_0[t_0, t^{n-1}]$ to be zero for all t^{n-1} .

We will examine a Lagrangian relaxation associated with relaxing constraints of the form:

$$\sum_{t^{n-1} \in T^{n-1}} \mathbf{a}_i[t_i, t^{n-1}] \pi(t^{n-1}) - \sum_{t^{n-1} \in T^{n-1}} \mathbf{a}_{i+1}[t_{i+1}, t^{n-1}] \pi(t^{n-1}) \leq 0 \quad \forall i = 0, \dots, m-1.$$

Let λ_i be the multiplier associated with the i^{th} such constraint. The Lagrangian dual will be

$$\begin{aligned} Z(\lambda) = & \max_{\{\mathbf{a}\}} \sum_i \sum_{t^{n-1} \in T^{n-1}} n f_i \mathbf{a}_i[t_i, t^{n-1}] \left(i + \frac{1 - F(i)}{f_i} \right) \pi(t^{n-1}) - \\ & - \sum_{i=0}^m \lambda_i \left[\sum_{t^{n-1} \in T^{n-1}} \mathbf{a}_i[t_i, t^{n-1}] \pi(t^{n-1}) - \sum_{t^{n-1} \in T^{n-1}} \mathbf{a}_{i+1}[t_{i+1}, t^{n-1}] \pi(t^{n-1}) \right] \\ \text{s.t. } & \sum_i n_i(t) \mathbf{a}_i[t_i, t^{n-1}] \leq K \quad \forall t \in T^n \end{aligned}$$

To make the indices line up we take $\lambda_m = 0$.

A rearrangement yields

$$\begin{aligned} Z(\lambda) = & \max_{\{\mathbf{a}\}} \sum_{i=1}^m \sum_{t^{n-1} \in T^{n-1}} n f_i \mathbf{a}_i[t_i, t^{n-1}] \left(i + \frac{1 - F(i)}{f_i} - \frac{\lambda_i}{f_i} + \frac{\lambda_{i-1}}{f_i} \right) \pi(t^{n-1}) \\ \text{s.t. } & \sum_i n_i(t) \mathbf{a}_i[t_i, t^{n-1}] \leq K \quad \forall t \in T^n \end{aligned}$$

This problem is decomposable into one subproblem for each profile $t \in T^n$ as follows:

$$\begin{aligned} g(t, \lambda) = & \max_{\{\mathbf{a}\}} \sum_i n_i(t) \left(i - \frac{1 - F(i)}{f_i} - \frac{\lambda_i}{f_i} + \frac{\lambda_{i-1}}{f_i} \right) \mathbf{a}_i(t) \\ \text{s.t. } & \sum_i n_i(t) \mathbf{a}_i(t) \leq K \end{aligned}$$

This is also a continuous knapsack problem and it is easy to see that

$$g(t, \lambda) = \max \left\{ 0, K \max_{i: n_i(t) > 0} \left(i - \frac{1 - F(i)}{f_i} - \frac{\lambda_i}{f_i} + \frac{\lambda_{i-1}}{f_i} \right) \right\}.$$

Further $Z(\lambda) = \sum_{t \in T^n} g(t, \lambda) \pi(t)$. Now $Z = \min_{\lambda \geq 0} Z(\lambda)$. We can formulate $\min_{\lambda \geq 0} Z(\lambda)$ as a linear program as follows:

$$\min_{\lambda_0, \dots, \lambda_m} \sum_{t \in T^n} \pi(t) W_t \tag{IP}$$

$$\text{s.t. } W_t \geq \left(i - \frac{1 - F(i)}{f_i} - \frac{\lambda_i}{f_i} + \frac{\lambda_{i-1}}{f_i} \right) \quad \forall t \in T^n, \forall n_i(t) > 0$$

$$W_t \geq 0 \quad \forall t \in T^n$$

$$\lambda_i \geq 0 \quad i = 1, \dots, m$$

$$\lambda_m = 0$$

Let λ^* be the optimal solution to the above (IP) problem. We refer to

$$i - \frac{1 - F(i)}{f_i} - \frac{\lambda_i^*}{f_i} + \frac{\lambda_{i-1}^*}{f_i}$$

as type i 's *ironed* virtual valuation.

Theorem 5 *There exists an optimal solution to (IP) where the ironed virtual valuations are monotonic.*

Proof. Call the support of a profile t the set of $i \in \{1, \dots, m\}$ such that $n_i(t) > 0$. If two profiles t and t' have the same support then it is easy to see that there is an optimal solution to (IP) such that $W_t = W_{t'}$. This observation allows us to reformulate (IP) using different variables. For any $S \subseteq \{1, \dots, m\}$ let $\phi(S)$ denote the probability of a profile with support S . Then (IP) can be rewritten as

$$\min_{\lambda_0, \dots, \lambda_m} \sum_S \phi(S) H(S) \tag{IP'}$$

$$\text{s.t. } H(S) \geq i - \frac{1 - F(i)}{f_i} - \frac{\lambda_i}{f_i} + \frac{\lambda_{i-1}}{f_i} \quad \forall S, \forall i \in S \tag{2}$$

$$H(S) \geq 0 \quad \forall S$$

$$\lambda_i \geq 0 \quad i = 1, \dots, m$$

$$\lambda_m = 0$$

Denote $h_i^* = i - \frac{1 - F(i)}{f_i} - \frac{\lambda_i^*}{f_i} + \frac{\lambda_{i-1}^*}{f_i}$ for all i where λ^* is an optimal solution to the (IP') problem above.

Suppose for a contradiction that there is no optimal solution λ^* to (IP') where $\{h_i^*\}_{i=0}^m$ are monotonic. Denote the discrepancy of an optimal solution λ^* to (IP') by $\sum_i \max\{h_{i-1}^* - h_i^*, 0\}$. Amongst all optimal solutions to (IP') pick the one that has the smallest discrepancy. If the discrepancy is zero, we are done. So, suppose not. Therefore there exists at least one j , such that $h_{j-1}^* > h_j^*$. If there exist more than one j such that $h_{j-1}^* > h_j^*$, choose the largest j , for which $h_{j-1}^* > h_j^*$.

First, consider the case when there exists at least one $l \geq j$, such that $h_j^* < h_{l+1}^*$. If there exist more than one such l , choose the smallest l , for which $h_j^* < h_{l+1}^*$.⁵

We construct a contradiction by considering a new set of $\{\lambda'_i\}_{i=0}^m$, such that

$$\begin{aligned}\lambda'_{j-1} &= \lambda_{j-1}^* + \varepsilon, \\ \lambda'_i &= \lambda_i^* - \varepsilon \quad \forall i \in [j, l], \\ \lambda'_i &= \lambda_i^* \quad \forall i \in [1, j-2] \cup [l+1, m].\end{aligned}$$

Denote $h'_i = i - \frac{1-F(i)}{f_i} - \frac{\lambda'_i}{f_i} + \frac{\lambda'_{i-1}}{f_i}$ for all i . This change results in the following changes to the values of $\{h_i^*\}_{i=0}^m$:

$$\begin{aligned}h'_{j-1} &= h_{j-1}^* - \frac{\varepsilon}{f_{j-1}}, \\ h'_j &= h_j^* + 2\frac{\varepsilon}{f_j}, \\ h'_{l+1} &= h_{l+1}^* - \frac{\varepsilon}{f_{l+1}}, \\ h'_i &= h_i^* \quad \forall i \notin \{j-1, j, l+1\}.\end{aligned}$$

Denote the change in the (IP') problem objective function from changing λ^* to λ' by ΔZ . Consider the sets S , for which $H(S)$ are affected by this change (recall that $H(S)$ reflects the highest value of the right hand side in (2)).

For $\varepsilon > 0$ sufficiently small, decreasing h_{j-1}^* by $\frac{\varepsilon}{f_{j-1}}$ affects $H(S)$ only if $j-1 \in S$ and $h_k^* < h_{j-1}^*$ for all $k \in S \setminus \{j-1\}$. Similarly the decrease of h_{l+1}^* by $\frac{\varepsilon}{f_{l+1}}$ affects $H(S)$ if $l+1 \in S$ and $h_k^* < h_{l+1}^*$ for all $k \in S \setminus \{l+1\}$. So the corresponding affected sets S are of the form:

$$\begin{aligned}\{j-1 \in S \text{ and } h_k^* < h_{j-1}^* \text{ for all } k \in S \setminus \{j-1\}\}, \\ \{l+1 \in S \text{ and } h_k^* < h_{l+1}^* \text{ for all } k \in S \setminus \{l+1\}\}.\end{aligned}$$

For $\varepsilon > 0$ sufficiently small, increasing h_j^* by $2\frac{\varepsilon}{f_j}$ affects $H(S)$ only if $j \in S$ and $h_k \leq h_j$ for all $k \in S \setminus \{j\}$. So the sets S affected by the upward change in h_j^* are of the form:

$$\{j \in S \text{ and } h_k^* \leq h_j^* \text{ for all } k \in S \setminus \{j\}\}.$$

Let

$$\begin{aligned}P_j^* &= \Pr(S : j \in S, h_k^* \leq h_j^* \quad \forall k \in S \setminus \{j\}), \\ P_{j-1}^* &= \Pr(S : j-1 \in S, h_k^* < h_{j-1}^* \quad \forall k \in S \setminus \{j-1\}), \\ P_{l+1}^* &= \Pr(S : l+1 \in S, h_k^* < h_{l+1}^* \quad \forall k \in S \setminus \{l+1\}).\end{aligned}$$

⁵It is possible that $l = j$.

Then

$$\begin{aligned} P_j^* &= f_j \Pr(n-1 \text{ draws from } \{1, \dots, m\} \text{ and all have } h_k^* \leq h_j^*), \\ P_{j-1}^* &= f_{j-1} \Pr(n-1 \text{ draws from } \{1, \dots, m\} \text{ and all have } h_k^* < h_{j-1}^*), \\ P_{l+1}^* &= f_{l+1} \Pr(n-1 \text{ draws from } \{1, \dots, m\} \text{ and all have } h_k^* < h_{l+1}^*). \end{aligned}$$

Let

$$\begin{aligned} \Pr(h_j^*) &= \Pr(n-1 \text{ draws from } \{1, \dots, m\} \text{ and all have } h_k^* \leq h_j^*), \\ \Pr(h_{j-1}^*) &= \Pr(n-1 \text{ draws from } \{1, \dots, m\} \text{ and all have } h_k^* < h_{j-1}^*), \\ \Pr(h_{l+1}^*) &= \Pr(n-1 \text{ draws from } \{1, \dots, m\} \text{ and all have } h_k^* < h_{l+1}^*). \end{aligned}$$

From the choice of j and l we have that $h_j^* < h_{j-1}^*$, and $h_j^* < h_{l+1}^*$. Hence we deduce that

$$\begin{aligned} \Pr(h_j^*) &\leq \Pr(h_{j-1}^*), \\ \Pr(h_j^*) &\leq \Pr(h_{l+1}^*). \end{aligned}$$

The change in the objective function ΔZ is:

$$\Delta Z \leq 2\varepsilon \Pr(h_j^*) - \varepsilon \Pr(h_{j-1}^*) - \varepsilon \Pr(h_{l+1}^*).$$

Hence $\Delta Z \leq 0$, and we conclude that λ' is also an optimal solution to (IP') . Computing the change in discrepancy from λ^* to λ' we observe that $\max\{h_{j-2} - h_{j-1}, 0\}$ can increase by at most ε/f_{j-1} , the term $\max\{h_{j-1} - h_j, 0\}$ goes down by $\varepsilon/f_{j-1} + 2\varepsilon/f_j$, the term $\max\{h_j - h_{j+1}, 0\}$ goes up by $2\varepsilon/f_j$, and the term $\max\{h_l - h_{l+1}, 0\}$ goes down by ε/f_{l+1} . The contribution to discrepancy from other terms is unchanged.⁶ Notice that the discrepancy changes by $\varepsilon/f_{j-1} - (\varepsilon/f_{j-1} + 2\varepsilon/f_j) + 2\varepsilon/f_j - \varepsilon/f_{l+1} < 0$, contradicting our choice of λ^* as the one with the smallest discrepancy.

Now consider the case when there is no $l \geq j$, such that $h_j^* < h_{l+1}^*$. This implies that $h_j^* = h_{j+1}^* = \dots = h_m^*$.⁷

We construct a contradiction by considering a new set of $\{\lambda'_i\}_{i=0}^m$, such that

$$\begin{aligned} \lambda'_i &= \lambda_i^* + \varepsilon \quad \forall i \in [j-1, m-1], \\ \lambda'_i &= \lambda_i^* \quad \forall i \notin [j-1, m-1]. \end{aligned}$$

⁶Notice that in the case when $l = j$, the term $\max\{h_j - h_{j+1}, 0\}$ is also unchanged for a small enough $\varepsilon > 0$.

⁷It is possible that $j = m$.

Denote $h'_i = i - \frac{1-F(i)}{f_i} - \frac{\lambda'_i}{f_i} + \frac{\lambda'_{i-1}}{f_i}$ for all i . This change results in the following changes to the values of $\{h_i^*\}_{i=0}^m$:

$$\begin{aligned} h'_{j-1} &= h_{j-1}^* - \frac{\varepsilon}{f_{j-1}}, \\ h'_m &= h_m^* + \frac{\varepsilon}{f_m}, \\ h'_i &= h_i^* \quad \forall i \notin \{j-1, m\}. \end{aligned}$$

Denote the change in the (IP') problem objective function from changing λ^* to λ' by ΔZ . Consider the sets S for which $H(S)$ are affected by this change (recall that $H(S)$ reflects the highest value of the right hand side in (2)).

For $\varepsilon > 0$ sufficiently small, decreasing h_{j-1}^* by $\frac{\varepsilon}{f_{j-1}}$ affects $H(S)$ only if $j-1 \in S$ and $h_k^* < h_{j-1}^*$ for all $k \in S \setminus \{j-1\}$. So the sets S affected by the downward change in h_{j-1}^* are of the form:

$$\{j-1 \in S \text{ and } h_k^* < h_{j-1}^* \text{ for all } k \in S \setminus \{j-1\}\}.$$

For $\varepsilon > 0$ sufficiently small, increasing h_m^* by $\frac{\varepsilon}{f_m}$ affects $H(S)$ only if $m \in S$ and $h_k^* \leq h_m^*$ for all $k \in S \setminus \{m\}$. So the sets S affected by the upward change in h_m^* are of the form:

$$\{m \in S \text{ and } h_k^* \leq h_m^* \text{ for all } k \in S \setminus \{m\}\}.$$

Let

$$\begin{aligned} P_{j-1}^* &= \Pr(S : j-1 \in S, h_k^* < h_{j-1}^* \quad \forall k \in S \setminus \{j-1\}), \\ P_m^* &= \Pr(S : m \in S, h_k^* \leq h_m^* \quad \forall k \in S \setminus \{m\}). \end{aligned}$$

Then

$$\begin{aligned} P_{j-1}^* &= f_{j-1} \Pr(n-1 \text{ draws from } \{1, \dots, m\} \text{ and all have } h_k^* < h_{j-1}^*), \\ P_m^* &= f_m \Pr(n-1 \text{ draws from } \{1, \dots, m\} \text{ and all have } h_k^* \leq h_m^*). \end{aligned}$$

Let

$$\begin{aligned} \Pr(h_{j-1}^*) &= \Pr(n-1 \text{ draws from } \{1, \dots, m\} \text{ and all have } h_k^* < h_{j-1}^*), \\ \Pr(h_m^*) &= \Pr(n-1 \text{ draws from } \{1, \dots, m\} \text{ and all have } h_k^* \leq h_m^*). \end{aligned}$$

Since $h_j^* < h_{j-1}^*$ and $h_j^* = h_m^*$ we deduce that

$$\Pr(h_m^*) \leq \Pr(h_{j-1}^*).$$

The change in the objective function ΔZ is:

$$\Delta Z \leq \varepsilon Pr(h_m^*) - \varepsilon Pr(h_{j-1}^*) \leq 0.$$

This contradicts the optimality of λ^* if $\Delta Z < 0$, or implies that λ' is also an optimal solution to (IP') if $\Delta Z = 0$. In the latter case, we compute the change in discrepancy from λ^* to λ' . Notice that $\max\{h_{j-2} - h_{j-1}, 0\}$ can increase by at most ε/f_{j-1} , and the term $\max\{h_{j-1} - h_j, 0\}$ goes down by $\varepsilon/f_{j-1} + \varepsilon/f_j$. The contribution to discrepancy from other terms is unchanged. Hence the discrepancy changes by $\varepsilon/f_{j-1} - (\varepsilon/f_{j-1} + \varepsilon/f_j) = -\varepsilon/f_j < 0$, contradicting our choice of λ^* as the optimal solution with the smallest discrepancy.

As we see, both possibilities for a choice of an optimal solution λ^* the (IP') problem with the smallest positive discrepancy lead to contradictions with the optimality of λ^* . Therefore, there exists an optimal solution to (IP) with the monotonic ironed virtual valuations $\{h_i^*\}_{i=0}^m$. ■

We can now repeat the analysis of Section 3.2 with the virtual valuations replaced by the ironed virtual valuations.

3.4 Comparison with Continuous Approach

Consider Myerson's (1981) approach in the case of a seller with K units of a divisible good who is selling it to n buyers with independent private valuations $v(q|i) = iq$, where buyers' types i are distributed on a continuous interval $[\underline{i}, \bar{i}]$ according to the pdf function $f(i)$. The central idea of Myerson's (1981) approach is the use of the indirect buyers utility function $U(i) = i\mathcal{A}_i - P_i$. We can then rewrite IC constraints using the indirect utility function as

$$U(i) \geq i\mathcal{A}_{i'} - P_{i'} \quad \forall i, i', \quad (3)$$

$$U(i') \geq i'\mathcal{A}_i - P_i \quad \forall i, i'. \quad (4)$$

Combining (3) and (4) gives

$$(i - i')\mathcal{A}_{i'} \leq U(i) - U(i') \leq (i - i')\mathcal{A}_i, \quad (5)$$

which implies that \mathcal{A}_i and $U(i)$ are non-decreasing. The monotonicity of \mathcal{A}_i implies that it is a.e. continuous. Thus, rewriting (5) as

$$\mathcal{A}_{i'} \leq \frac{U(i) - U(i')}{i - i'} \leq \mathcal{A}_i,$$

and taking limits as $i' \rightarrow i$ at points where \mathcal{A}_i is continuous, we conclude that $U'(i) = \mathcal{A}_i$ a.e., which in turn immediately gives absolute continuity of $U(i)$, and hence

$$U(i) = U(\underline{i}) + \int_{\underline{i}}^i \mathcal{A}_v dv,$$

and

$$P_i = i\mathcal{A}_i - \int_{\underline{i}}^i \mathcal{A}_v dv - U(\underline{i}). \quad (6)$$

The expression (6) is a continuous analog of the discrete expression (1), and can be interpreted as if the payment P_i was set by following a continuous path from the outside option, that is given by the indirect utility for the lowest type \underline{i} , to type i through a continuous set (or graph) $[\underline{i}, \bar{i}]$. It is important to observe that this path represents the shortest path consistent with binding IC constraints along the way (in the continuous case, we can interpret that IC constraints for a buyer of type i do bind in an infinitesimal neighborhood of i). Fortunately, there is only one possible direction for the shortest path between the lowest possible type, and type i in one dimension, i.e. the path that goes through all intermediate types between the lowest possible type, and type i , and there is absolutely no conceptual difference between continuous and discrete approaches. In the multi-dimensional case there are significant differences between the continuous and discrete approaches.

Ironing in the model of discrete types is conceptually similar, but computationally easier than in the continuous type model. The continuous type case requires the solution of a Hamiltonian problem, in the discrete case a linear program.

4 Multi-Dimensional Types

4.1 Continuous Approach Overview

Consider the case when buyers have multi-dimensional types $i = \{i_1, \dots, i_D\}$, which are distributed on Ω , a convex compact subset of \mathbf{R}_+^D , with a density function $f(t)$ being continuous on Ω with $\text{supp}(f) = \Omega$. Buyers' private valuations given by $v(\mathbf{a}|i) = i \cdot \mathbf{a} = \sum_{j=1}^D i_j \mathbf{a}_j$, where allocations $\mathbf{a} = \{\mathbf{a}_1, \dots, \mathbf{a}_D\}$ belong to \mathbf{R}^D . Denoting the expected allocations and payment for the buyer of type i in a direct mechanism as $\mathcal{A}_i = \{\mathcal{A}_1, \dots, \mathcal{A}_D\}$ and P_i respectively, we can write down the indirect utility function as $U(i) = i \cdot \mathcal{A}_i - P_i$. As with one-dimensional types, we can rewrite the

IC constraints using the indirect utility function as

$$U(i) \geq i\mathcal{A}_{i'} - P_{i'} \quad \forall i, i', \quad (7)$$

$$U(i') \geq i'\mathcal{A}_i - P_i \quad \forall i, i'. \quad (8)$$

Combining (7) and (8) gives

$$(i - i')\mathcal{A}_{i'} \leq U(i) - U(i') \leq (i - i')\mathcal{A}_i, \\ \mathcal{A}_{i'} \leq \frac{U(i) - U(i')}{i - i'} \leq \mathcal{A}_i. \quad (9)$$

If $U(i)$ were differentiable a.e., then taking limits in (9) as $\Delta(i' - i)_d \rightarrow 0$ in each dimension d , immediately yields that $\nabla U(i) = \mathcal{A}_i$, and

$$U(i) = U(\underline{i}) + \int_l \mathcal{A}_v dv, \quad (10)$$

$$P_i = i\mathcal{A}_i - \int_l \mathcal{A}_v dv - U(\underline{i}). \quad (11)$$

for any path l in Ω connecting any two types \underline{i} and i . Hence the choice of the path to type i through Ω in order to determine the payment P_i does not matter if in the case of multi-dimensional continuous types, if the indirect utility function $U(i)$ is differentiable.

Notice that we do not need differentiability of $U(i)$ to obtain partial derivatives *a.e.*, and to form the gradient. Indeed, taking limits in (9) as $(i' - i)_d \rightarrow 0$ in each dimension d , yields $\nabla U(i) = \mathcal{A}_i$. Unfortunately, even the existence of partial derivatives, does not guarantee differentiability of $U(i)$ in the multi-dimensional case,⁸ hence the expression (11) can not be viewed as a multi-dimensional analog of (6). A general representation of rationalizable preferences in terms of the indirect utility function was provided by Rochet (1987), and reformulated in terms of incentive-compatible allocations for the study of optimal mechanisms in Rochet and Choné (1998) as follows:

There exist expected allocation and price schedules such that the IC constraints are satisfied for a.e. i if and only if

1. $\mathcal{A}_i = \nabla U(i)$ for a.e. i in Ω ,
2. U is convex and continuous on Ω .

Notice that $\mathcal{A}_i = \nabla U(i)$ does not imply differentiability of $U(i)$, hence the only analog for expression (10) is

$$P_i = i \cdot \nabla U(i) - U(i). \quad (12)$$

⁸See Example 1 in Krishna and Perry (2000) for a nondifferentiable indirect utility function.

The closest analog to the expression (6) in the multi-dimension context is given in Krishna and Perry (2000) as a payoff equivalence result that states that an IC mechanism's indirect utility function $U(i)$ is determined by \mathcal{A}_i up to an additive constant, i.e.

$$U(i) = U(\underline{i}) + \int_0^1 \mathcal{A}_{ri+(1-r)\underline{i}}(i - \underline{i})dr. \quad (13)$$

The above expression gives

$$P_i = i\mathcal{A}_i - \int_0^1 \mathcal{A}_{ri+(1-r)\underline{i}}(i - \underline{i})dr - U(\underline{i}). \quad (14)$$

The expression (14) is a multi-dimensional analog of the discrete expression (6), and can be interpreted as if the payment P_i was set by following a straight path from a type \underline{i} , where IR constraint binds to type i through Ω . Unfortunately, there is no direct analog to the above approach in the discrete multi-dimensional case. The reason for that lies in the fact that although the payment P_i for a particular allocation scheme is given by the shortest path⁹ towards the vertex i , there is no analog to the gradient of the indirect utility function in the multi-dimensional discrete case. Indeed, the incremental indirect utility $\Delta U(i)$ at the vertex i is determined by the edge (i', i) originating in one of adjacent vertices i' , along which the IC constraint binds. This binding IC constraint also gives the direction of the increase in the indirect utility, but this direction can not be averaged out to form an average direction of the indirect utility increase (i.e. the indirect utility gradient) due to the discrete nature of this direction.

This logic shows that the indirect utility approach does not work in the discrete multi-dimensional case, and that we have to rely on an enumeration of all the binding IC constraints and the corresponding shortest paths through the multi-dimensional lattice in order to find a solution to the optimal auction problem.¹⁰ The general discrete approach naturally leads to the revenue equivalence result, since participants' payments are given by shortest paths lengths, hence the seller's expected revenue in any incentive compatible mechanism is uniquely given by the allocation schedule. Notice that the revenue equivalence result is not obvious in the multi-dimensional continuous case.

⁹Notice that the IC constraints bind along the shortest path, which can be interpreted as having the shortest path at each vertex follows the direction of the IC constraint that binds at that vertex.

¹⁰It is interesting to note similarities of the most general approach to incentive compatible allocation rules in the discrete and continuous multidimensional cases. Both our analysis in the discrete case, and Rochet (1987) in the continuous case characterize incentive compatible allocation rules through the absence of a negative cycle in the network.

Solving for an optimal mechanism in a multi-dimensional environment is a hard problem in either the discrete or continuous case. Not surprisingly, many results in which there is an explicit solution to a multi-dimensional optimal mechanism rely on some properties of the problem that can either reduce it to a one-dimensional case (Wilson (1993)), or help with reducing the set of available options in (Maskin (2002)). In Sections 5 and 6 we examine specific cases when it is possible to reduce available options, and simplify the multi-dimensional analysis in the discrete framework.

4.2 Discrete Approach

The problem of finding an optimal auction when types are multi-dimensional is considered to be hard problem in the sense that no ‘closed form’ solution of the types found in the one-dimensional case are possible. In this section we highlight the main difficulty is in extending previous results to the multi-dimensional case. It turns out that the difficulties present themselves in two dimensions. We concentrate on that case.

Denote a bidders type as (i, j) , where $i \in \{1, \dots, I\}$, and $j \in \{1, \dots, J\}$ without the loss of generality. Let f_{ij} be the probability that an agent has type (i, j) . These bidders may obtain various quantities of a homogeneous good. Each agent has a utility $v(q|i, j)$ from getting q units of the good. Also assume that $v(q|i, j)$ satisfies increasing differences. That is, if $q' \geq q$ and $(i', j') \geq (i, j)$ then

$$v(q'|i', j') - v(q|i', j') \geq v(q'|i, j) - v(q|i, j).$$

Denote by \mathcal{A}_{ij} the expected amount assigned to an agent who reports (i, j) . Then the following is true:

Theorem 6 *Any incentive compatible allocation rule must be monotonic. That is for all $(i, j) \geq (i', j')$ we have $\mathcal{A}_{ij} \geq \mathcal{A}_{i'j'}$.*

Proof. Similar to the proof of Theorem 1. First show monotonicity for (i, j) vs. (i, j') then for (i, j) vs. (i', j') . ■

We have 6 types of IC constraints that are displayed for $(i, j) < (i', j')$ in figure 3 below:

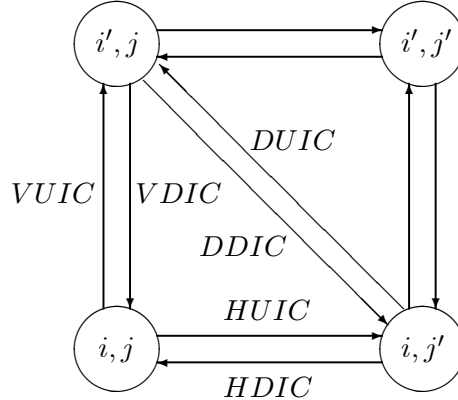

Figure 3

1. Horizontal Upward IC (HUIC)

Type (i, j) reporting (i', j) where $i' > i$:

$$v(\mathcal{A}_{i,j}|i, j) - P_{i,j} \geq v(\mathcal{A}_{i',j}|i, j) - P_{i',j}.$$

2. Horizontal Downward IC (HDIC)

Type (i, j) reporting (i', j) where $i' < i$:

$$v(\mathcal{A}_{i,j}|i, j) - P_{i,j} \geq v(\mathcal{A}_{i',j}|i, j) - P_{i',j}.$$

3. Vertical Upward IC (VUIC)

Type (i, j) reporting (i, j') where $j' > j$:

$$v(\mathcal{A}_{i,j}|i, j) - P_{i,j} \geq v(\mathcal{A}_{i,j'}|i, j) - P_{i,j'}.$$

4. Vertical Downward IC (VDIC)

Type (i, j) reporting (i, j') where $j' < j$:

$$v(\mathcal{A}_{i,j}|i, j) - P_{i,j} \geq v(\mathcal{A}_{i,j'}|i, j) - P_{i,j'}.$$

5. Diagonal Upward IC (DDIC)

Type (i, j) reporting (i', j') where $i' > i$ and $j' < j$:

$$v(\mathcal{A}_{i,j}|i, j) - P_{i,j} \geq v(\mathcal{A}_{i',j'}|i, j) - P_{i',j'}.$$

6. Diagonal Downward IC (DUIC)

Type (i, j) reporting (i', j') where $i' < i$ and $j' > j$:

$$v(\mathcal{A}_{i,j}|i, j) - P_{i,j} \geq v(\mathcal{A}_{i',j'}|i, j) - P_{i',j'}.$$

The new wrinkle that multi-dimensionality adds are the diagonal IC constraints. The reader will notice the omission of diagonal IC constraints relating type (i, j) with type $(i', j') \geq (i, j)$. This is because they are implied by a combination of the horizontal and vertical IC constraints. This is shown below. Consider the following diagonal IC constraints

$$v(\mathcal{A}_{i+1,j+1}|i+1, j+1) - P_{i+1,j+1} \geq v(\mathcal{A}_{i,j}|i+1, j+1) - P_{i,j}. \quad (15)$$

To see that the above ‘diagonal’ downward IC constraint is implied by the horizontal and vertical adjacent downward IC constraints consider:

$$v(\mathcal{A}_{i+1,j+1}|i+1, j+1) - P_{i+1,j+1} \geq v(\mathcal{A}_{i,j+1}|i+1, j+1) - P_{i,j+1}$$

and

$$v(\mathcal{A}_{i,j+1}|i, j+1) - P_{i,j+1} \geq v(\mathcal{A}_{i,j}|i, j+1) - P_{i,j}.$$

Adding these two inequalities together yields:

$$v(\mathcal{A}_{i+1,j+1}|i+1, j+1) - P_{i+1,j+1} + v(\mathcal{A}_{i,j+1}|i, j+1) \geq v(\mathcal{A}_{i,j+1}|i+1, j+1) + v(\mathcal{A}_{i,j}|i, j+1) - P_{i,j}.$$

Rearranging:

$$\begin{aligned} & v(\mathcal{A}_{i+1,j+1}|i+1, j+1) - v(\mathcal{A}_{i,j}|i+1, j+1) - [P_{i+1,j+1} - P_{i,j}] \geq \\ & \geq [v(\mathcal{A}_{i,j+1}|i+1, j+1) - v(\mathcal{A}_{i,j}|i+1, j+1)] - [v(\mathcal{A}_{i,j+1}|i, j+1) - v(\mathcal{A}_{i,j}|i, j+1)]. \end{aligned}$$

The increasing differences property and the monotonicity of the allocation imply that

$$[v(\mathcal{A}_{i,j+1}|i+1, j+1) - v(\mathcal{A}_{i,j}|i+1, j+1)] - [v(\mathcal{A}_{i,j+1}|i, j+1) - v(\mathcal{A}_{i,j}|i, j+1)] \geq 0,$$

and hence we have that

$$v(\mathcal{A}_{i+1,j+1}|i+1, j+1) - v(\mathcal{A}_{i,j}|i+1, j+1) \geq P_{i+1,j+1} - P_{i,j}$$

which is equivalent to (15), and thus proves the the adjacent diagonal downward constraint follows the horizontal and vertical adjacent in 1D downward constraints. The rest, i.e. all possible non-adjacent downward constraints, follow from a simple induction. Notice that the argument did not rely on a specific functional form of v .

A similar argument applies to the diagonal IC constraint:

$$v(\mathcal{A}_{i,j}|i, j) - P_{i,j} \geq v(\mathcal{A}_{i+1,j+1}|i, j) - P_{i+1,j+1}. \quad (16)$$

The above diagonal IC constraint is implied by the following horizontal and vertical adjacent upward IC constraints:

$$v(\mathcal{A}_{i+1,j}|i+1, j) - P_{i+1,j} \geq v(\mathcal{A}_{i+1,j+1}|i+1, j) - P_{i+1,j+1}$$

and

$$v(\mathcal{A}_{i,j}|i, j) - P_{ij} \geq v(\mathcal{A}_{i+1,j}|i, j) - P_{i+1,j}.$$

Adding these two inequalities together yields:

$$v(\mathcal{A}_{i,j}|i, j) - v(\mathcal{A}_{i+1,j+1}|i+1, j) + v(\mathcal{A}_{i+1,j}|i+1, j) - v(\mathcal{A}_{i+1,j}|i, j) \geq P_{ij} - P_{i+1,j+1}.$$

Rearranging:

$$\begin{aligned} & v(\mathcal{A}_{i,j}|i, j) - v(\mathcal{A}_{i+1,j+1}|i, j) - [P_{ij} - P_{i+1,j+1}] \geq \\ & \geq [v(\mathcal{A}_{i+1,j+1}|i+1, j) - v(\mathcal{A}_{i+1,j}|i+1, j)] - [v(\mathcal{A}_{i+1,j+1}|i, j) - v(\mathcal{A}_{i+1,j}|i, j)]. \end{aligned}$$

The increasing differences property and the monotonicity of the allocation imply that

$$[v(\mathcal{A}_{i+1,j+1}|i+1, j) - v(\mathcal{A}_{i+1,j}|i+1, j)] - [v(\mathcal{A}_{i+1,j+1}|i, j) - v(\mathcal{A}_{i+1,j}|i, j)] \geq 0,$$

and hence we have that

$$v(\mathcal{A}_{i,j}|i, j) - v(\mathcal{A}_{i+1,j+1}|i, j) \geq P_{ij} - P_{i+1,j+1}$$

which is equivalent to (16).

As in the one-dimensional case we have:

Theorem 7 *Only the adjacent downward constraints w.r.t. $(i+1, j)$ and (i, j) and w.r.t $(i, j+1)$ and (i, j) matter out of all horizontal and vertical downward constraints. Only the adjacent upward constraints w.r.t. (i, j) and $(i+1, j)$, w.r.t. (i, j) and $(i, j+1)$ matter out of all horizontal and vertical upward constraints.*

The theorem does not hold for the DDIC and DUIC constraints.

Theorem 8 *If an adjacent HDIC or VDIC constraint binds, the corresponding adjacent upward IC constraint is redundant.*

Proof. Given that the corresponding downward adjacent IC constraint binds, i.e. then upward IC constraints are redundant. Indeed, if

$$v(\mathcal{A}_{i+1,j}|i+1, j) - v(\mathcal{A}_{i,j}|i+1, j) = P_{i+1,j} - P_{i,j},$$

then by increasing differences and monotonicity of the allocation rule:

$$v(\mathcal{A}_{i+1,j}|i, j) - v(\mathcal{A}_{i,j}|i, j) \leq P_{i+1,j} - P_{i,j},$$

which is the corresponding upward constraint $v(\mathcal{A}_{i,j}|i, j) - P_{i,j} \geq v(\mathcal{A}_{i+1,j}|i, j) - P_{i+1,j}$. So the corresponding adjacent upward IC constraint is redundant. The argument is exactly the same in w.r.t. the j dimension. ■

Notice that when an adjacent HDIC constraint does not bind, the corresponding adjacent HUIIC constraint is not automatically satisfied, and may have a bite. Also notice that some of the adjacent downward IC constraints would be slack since not all edges would likely to be used in optimal (i.e. shortest) paths to all vertices.

4.3 Non-redundancy of Diagonal IC's

The difficulty that multi-dimensional types introduces is in the diagonal IC's. Their presence makes it difficult to pin down the path in the underlying network that determines $P_{i,j}$ for each (i, j) . One might hope that they are redundant. They are not. This can be seen by examining the adjacent DUIIC constraint:

$$v(\mathcal{A}_{i+1,j}|i+1, j) - P_{i+1,j} \geq v(\mathcal{A}_{i,j+1}|i+1, j) - P_{i,j+1}.$$

It can be rewritten as

$$v(\mathcal{A}_{i+1,j}|i+1, j) - v(\mathcal{A}_{i,j+1}|i+1, j) \geq P_{i+1,j} - P_{i,j+1}.$$

Perhaps it can be replicated by following the path $(i+1, j) \rightarrow (i, j) \rightarrow (i, j+1)$, i.e. by adding the following:

$$\begin{aligned} v(\mathcal{A}_{i+1,j}|i+1, j) - P_{i+1,j} &\geq v(\mathcal{A}_{i,j}|i+1, j) - P_{i,j}, \\ v(\mathcal{A}_{i,j}|i, j) - P_{i,j} &\geq v(\mathcal{A}_{i,j+1}|i, j) - P_{i,j+1}. \end{aligned}$$

This yields:

$$v(\mathcal{A}_{i+1,j}|i+1, j) - v(\mathcal{A}_{i,j}|i+1, j) + v(\mathcal{A}_{i,j}|i, j) - v(\mathcal{A}_{i,j+1}|i, j) \geq P_{i+1,j} - P_{i,j+1}.$$

Rearranging:

$$\begin{aligned} &v(\mathcal{A}_{i+1,j}|i+1, j) - v(\mathcal{A}_{i,j+1}|i+1, j) - [P_{i+1,j} - P_{i,j+1}] \geq \\ &\geq [v(\mathcal{A}_{i,j+1}|i, j) - v(\mathcal{A}_{i,j}|i, j)] - [v(\mathcal{A}_{i,j+1}|i+1, j) - v(\mathcal{A}_{i,j}|i+1, j)]. \end{aligned}$$

>From monotonicity and increasing differences applied to the last term:

$$[v(\mathcal{A}_{i,j+1}|i, j) - v(\mathcal{A}_{i,j}|i, j)] - [v(\mathcal{A}_{i,j+1}|i+1, j) - v(\mathcal{A}_{i,j}|i+1, j)] \leq 0. \quad (17)$$

If we could show that the left hand side of (17) was identically equal to 0, then the DUIC constraint would be redundant.

Another attempt could be made by following the path $(i+1, j) \rightarrow (i+1, j+1) \rightarrow (i, j+1)$, i.e. by adding the following:

$$\begin{aligned} v(\mathcal{A}_{i+1,j}|i+1, j) - P_{i+1,j} &\geq v(\mathcal{A}_{i+1,j+1}|i+1, j) - P_{i+1,j+1}, \\ v(\mathcal{A}_{i+1,j+1}|i+1, j+1) - P_{i+1,j+1} &\geq v(\mathcal{A}_{i,j+1}|i+1, j+1) - P_{i,j+1}. \end{aligned}$$

This gives

$$v(\mathcal{A}_{i+1,j}|i+1, j) - v(\mathcal{A}_{i+1,j+1}|i+1, j) + v(\mathcal{A}_{i+1,j+1}|i+1, j+1) - v(\mathcal{A}_{i,j+1}|i+1, j+1) \geq P_{i+1,j} - P_{i,j+1}.$$

Rearrangement produces

$$\begin{aligned} &v(\mathcal{A}_{i+1,j}|i+1, j) - v(\mathcal{A}_{i,j+1}|i+1, j) - [P_{i+1,j} - P_{i,j+1}] \geq \\ &\geq [v(\mathcal{A}_{i+1,j+1}|i+1, j) - v(\mathcal{A}_{i,j+1}|i+1, j)] - [v(\mathcal{A}_{i+1,j+1}|i+1, j+1) - v(\mathcal{A}_{i,j+1}|i+1, j+1)]. \end{aligned}$$

Again, by monotonicity and increasing differences

$$[v(\mathcal{A}_{i+1,j+1}|i+1, j) - v(\mathcal{A}_{i,j+1}|i+1, j)] - [v(\mathcal{A}_{i+1,j+1}|i+1, j+1) - v(\mathcal{A}_{i,j+1}|i+1, j+1)] \leq 0. \quad (18)$$

If we could show that the left hand side of (18) was identically equal to 0, then the DUIC constraint would be redundant.

A similar analysis holds for the DDIC constraints.

5 Capacitated Bidders

We now examine the problem of finding the revenue maximizing auction when bidders have constant marginal valuations as well as capacity constraints. Both the marginal values and capacity constraints are private information to the bidders.

A bidder's type consists of two numbers a and b . The first is the maximum amount they are willing to pay for each unit. The second, b , called her capacity, is the largest number of units she

seeks. Units beyond the b^{th} are worthless. If such an agent is assigned q units, she derives a utility of $a(q, b)^-$. The seller has Q units to sell.

Let the range of a be $R = \{1, 2, \dots, r\}$ and the range of b be $K = \{1, \dots, k\}$. Let f_{ij} be the probability that an agent has type (i, j) . The value that an agent of type (i, j) assigns to q units will be written $v(q|i, j) = i(q, j)^-$. Observe that $v(q|i, j)$ satisfies increasing differences. That is, if $q' \geq q$ and $(i', j') \geq (i, j)$ then

$$v(q'|i', j') - v(q|i', j') \geq v(q'|i, j) - v(q|i, j).$$

Without loss of generality we can assume that the amount assigned to an agent who reports type (i, j) will be at most j . If \mathcal{A}_{ij} is the **expected** amount assigned to an agent who reports (i, j) then because this agent receives at most j in any allocation, her expected payoff is $i\mathcal{A}_{ij}$.

The crucial assumption we make is that no bidder can inflate his capacity but can shade it down. In other words the auctioneer can verify, partially, the claims made by a bidder. This raises two questions. The first, is this plausible? Second, does it make the problem trivial.

In the selling context, which is what we have assumed, the assumption is odd. However, in a procurement setting it may not be. Consider a procurement auction where the auctioneer wishes to procure Q units from bidders with constant marginal costs and limited capacity. Both the marginal cost and capacity is the private information of the bidder. However, no bidder will inflate her capacity when bidding because of the huge penalties associated with not being able to fulfill the order. Equivalently, we may suppose that that the designer can verify that claims that exceed capacity are false.

Does limiting bidders to underreporting their capacities make the problem trivial? No. Consider the standard uniform price auction. This popular auction form is vulnerable to bidders underreporting their capacities. So, it is by no means obvious how to design an auction to cure this.

Let \mathcal{A}_{ij} denote the expected allocation that an agent who reports type (i, j) will receive in some direct mechanism and P_{ij} her expected payment.

5.1 The No-Inflation Assumption

In the discrete case, solving the optimal auction problem in 2-D requires finding binding IC constraints and identifying shortest paths through a two-dimensional lattice for all possible set of allocations. Potentially we may have to enumerate all possible collections of binding IC constraints.

Below we show that the no-inflation assumption allows us to simplify the analysis by removing some of the diagonal IC constraints, thus making the 2-D problem solvable by allowing us to pin down shortest paths through the 2-D lattice.

Recall that we can ignore diagonal IC constraints of the form:

$$v(\mathcal{A}_{kk}|k, k) - P_{kk} \geq v(\mathcal{A}_{jj}|k, k) - P_{jj}.$$

We now invoke the assumption that no bidder is permitted to inflate their capacity. With this assumption we can ignore IC constraints of the form:

$$v(\mathcal{A}_{ij}|i, j) - P_{ij} \geq v(\mathcal{A}_{i',j'}|i, j) - P_{i',j'}$$

where $j' > j$.

To see why consider the following IC constraint:

$$v(\mathcal{A}_{i,j+k}|i, j+k) - P_{i,j+k} \geq v(\mathcal{A}_{i+r,j}|i, j+k) - P_{i+r,j}.$$

When we substitute in our expression for v we obtain:

$$i\mathcal{A}_{i,j+k} - P_{i,j+k} \geq i\mathcal{A}_{i+r,j} - P_{i+r,j}. \quad (19)$$

We show that it is implied by the addition of the following vertical and horizontal IC constraints:

$$v(\mathcal{A}_{i,j+k}|i, j+k) - P_{i,j+k} \geq v(\mathcal{A}_{i,j}|i, j+k) - P_{i,j}, \quad (20)$$

$$v(\mathcal{A}_{i,j}|i, j) - P_{i,j} \geq v(\mathcal{A}_{i+r,j}|i, j) - P_{i+r,j}. \quad (21)$$

Adding (20) and (21) yields:

$$v(\mathcal{A}_{i,j+k}|i, j+k) - P_{i,j+k} + v(\mathcal{A}_{i,j}|i, j) \geq v(\mathcal{A}_{i,j}|i, j+k) + v(\mathcal{A}_{i+r,j}|i, j) - P_{i+r,j}. \quad (22)$$

Substitute in our expression for v :

$$i\mathcal{A}_{i,j+k} - P_{i,j+k} + i\mathcal{A}_{i,j} \geq i\mathcal{A}_{i,j} + i\mathcal{A}_{i+r,j} - P_{i+r,j}.$$

Cancelling common terms yields (19). There is no similar argument for eliminating a diagonal IC associated with bidders allowed to exaggerate their capacities. This is because in the inequalities we manipulate have a term of the form $v(\mathcal{A}_{ij}|i, j-k)$. Since \mathcal{A}_{ij} could exceed $j-k$ it is not true that $v(\mathcal{A}_{ij}|i, j-k) = i\mathcal{A}_{ij}$. Summarizing, the only IC constraints that matter are the adjacent HUIC, HDIC and DDIC.

5.2 A Formulation

Let t denote an n agent profile of types and t^{n-1} an $n - 1$ agent profile of types. Denote by $\mathbf{a}_{ij}[t]$ the *actual* allocation that a type (i, j) will receive under allocation rule \mathcal{A} when the announced profile is t . In the case when type (i, j) does not appear in the profile t we take $\mathbf{a}_{ij}[t] = 0$. We will have cause to study how the allocation for an agent with a given type, (i, j) say, will change when the types of the other $n - 1$ agents change. In these cases we will write $\mathbf{a}_{ij}(t)$ and $\mathbf{a}_{ij}[(i, j), t^{n-1}]$. Then $\mathcal{A}_{ij} = \sum_{t^{n-1}} \pi(t^{n-1}) \mathbf{a}_{ij}(t^{n-1})$ where $\pi(t^{n-1})$ is the probability of profile t^{n-1} being realized and the sum is over all possible profiles. Let $n_{ij}(t)$ denote the fraction of bidders in the profile t with type (i, j) .

We can now formulate the problem of finding the revenue maximizing allocation as a linear program in the following way. We drop all diagonal IC constraints as well as all the upward vertical and horizontal IC constraints. The HUIC constraints are the only ones we have not shown to be redundant. However, Theorem 8 ensures that HUIC will be satisfied. The problem we study is [OPT3] is:

$$\begin{aligned}
Z_3 &= \max_{P_{ij}} \sum_{i \in R} \sum_{j \in K} f_{ij} P_{ij} \\
\text{s.t. } & v(\mathcal{A}_{ij}|i, j) - P_{ij} \geq v(\mathcal{A}_{i-1,j}|i, j) - P_{i-1,j} \\
& v(\mathcal{A}_{ij}|i, j) - P_{ij} \geq v(\mathcal{A}_{i,j-1}|i, j) - P_{i,j-1} \\
& \mathcal{A}_{ij} \geq \mathcal{A}_{i'j'} \quad \forall (i, j) \geq (i', j') \\
& \mathcal{A}_{ij} = \sum_{t^{n-1}} \pi(t^{n-1}) \mathbf{a}_{ij}[(i, j), t^{n-1}] \quad \forall (i, j) \\
& \sum_{i \in R} \sum_{j \in K} n n_{ij}(t) \mathbf{a}_{ij}[t] \leq Q \quad \forall t \\
& \mathbf{a}_{ij}[t] \leq j \quad \forall i, j \quad \forall t
\end{aligned}$$

Now we describe a network representation of this linear program. Fix the \mathcal{A}_{ij} 's. For each type (i, j) introduce a vertex including the dummy type $(0, 0)$. For each pair $(i, j), (i + 1, j)$ introduce a directed edge from (i, j) to $(i + 1, j)$ with length $v(\mathcal{A}_{i+1,j}|i + 1, j) - v(\mathcal{A}_{ij}|i + 1, j) = (i + 1)\mathcal{A}_{i+1,j} - (i + 1)\mathcal{A}_{ij}$. Similarly a directed edge from (i, j) to $(i, j + 1)$ of length $i\mathcal{A}_{i,j+1} - i\mathcal{A}_{ij}$. Then P_{ij} will be the length of the shortest path from the dummy type $(0, 0)$ to (i, j) . We show that the shortest path from $(1, 1)$ to (i, j) is $(1, 1) \rightarrow (1, 2) \rightarrow (1, 3) \dots \rightarrow (1, j) \rightarrow (2, j) \dots \rightarrow (i, j)$.

Theorem 9

$$P_{ij} = v(\mathcal{A}_{ij}|i, j) - \sum_{r=1}^{i-1} [v(\mathcal{A}_{rj}|r+1, j) - v(\mathcal{A}_{rj}|r, j)] = \sum_{r=1}^i r(\mathcal{A}_{rj} - \mathcal{A}_{r-1,j}) - \mathcal{A}_{11} + P_{11}.$$

Proof. It suffices to show that the shortest path from $(1, 1)$ to (i, j) is straight up and across. The proof is by induction. It is clearly true for vertices $(1, 2)$ and $(2, 1)$. Consider the vertex $(2, 2)$. The length of $(1, 1) \rightarrow (2, 1) \rightarrow (2, 2)$ is

$$2\mathcal{A}_{22} - 2\mathcal{A}_{21} + 2\mathcal{A}_{21} - 2\mathcal{A}_{11} + P_{11} = 2\mathcal{A}_{22} - 2\mathcal{A}_{11} + P_{11}.$$

The length of the path $(1, 1) \rightarrow (1, 2) \rightarrow (2, 2)$ is

$$2\mathcal{A}_{22} - 2\mathcal{A}_{1,2} + \mathcal{A}_{1,2} - \mathcal{A}_{11} + P_{11} = 2\mathcal{A}_{22} - \mathcal{A}_{12} - \mathcal{A}_{11} + P_{11}.$$

The difference in length between the first and the second path is

$$(2\mathcal{A}_{22} - 2\mathcal{A}_{11}) - (2\mathcal{A}_{22} - \mathcal{A}_{12} - \mathcal{A}_{11}) = \mathcal{A}_{12} - \mathcal{A}_{11} \geq 0,$$

where the last inequality follows by monotonicity of the \mathcal{A} 's.

Now suppose the claim is true for all vertices (i, j) where $i, j \leq n-1$. The shortest path from $(1, 1)$ to $(1, n)$ is clearly up the top. A similar argument to the previous one shows that the shortest path from $(1, 1)$ to $(2, n)$ is also up the top and across. Consider now vertex $(3, n)$. There are two candidates for a shortest path from $(1, 1)$ to $(3, n)$. One is $(1, 1) \rightarrow (1, n-1) \rightarrow (3, n-1) \rightarrow (3, n)$. This path has length

$$3\mathcal{A}_{3n} - 3\mathcal{A}_{3,n-1} + 3\mathcal{A}_{3,n-1} - 3\mathcal{A}_{2,n-1} + 2\mathcal{A}_{2,n-1} - 2\mathcal{A}_{1,n-1} + P_{1,n-1} = 3\mathcal{A}_{3n} - \mathcal{A}_{2,n-1} - 2\mathcal{A}_{1,n-1} + P_{1,n-1}.$$

The other path, $(1, 1) \rightarrow (1, n) \rightarrow (3, n)$ has length

$$3\mathcal{A}_{3n} - 3\mathcal{A}_{2n} + 2\mathcal{A}_{2n} - 2\mathcal{A}_{1,n} + \mathcal{A}_{1,n} - \mathcal{A}_{1,n-1} + P_{1,n-1} = 3\mathcal{A}_{3n} - \mathcal{A}_{2n} - \mathcal{A}_{1,n} - \mathcal{A}_{1,n-1} + P_{1,n-1}.$$

The difference in length between the first and second path is

$$\mathcal{A}_{2n} + \mathcal{A}_{1n} + \mathcal{A}_{1,n-1} - \mathcal{A}_{2,n-1} - 2\mathcal{A}_{1,n-1} = \mathcal{A}_{2n} + \mathcal{A}_{1n} - \mathcal{A}_{2,n-1} - \mathcal{A}_{1,n-1} \geq 0.$$

Again the last inequality follows by monotonicity of the a 's.

Proceeding inductively in this way we can establish the claim for vertices of the form (i, n) where $i \leq n-1$ and for (n, j) where $j \leq n-1$. It remains then to prove the claim for vertex (n, n) . One path is $(1, n-1) \rightarrow (n, n-1) \rightarrow (n, n)$ and has length

$$n\mathcal{A}_{nn} - n\mathcal{A}_{n,n-1} + n\mathcal{A}_{n,n-1} - n\mathcal{A}_{n-1,n-1} + (n-1)\mathcal{A}_{n-1,n-1} - (n-1)\mathcal{A}_{n-2,n-1} + \dots + P_{1,n-1}$$

$$= n\mathcal{A}_{nn} - \mathcal{A}_{n-1,n-1} - \mathcal{A}_{n-2,n-1} - \dots + P_{1,n-1}.$$

The length of the other path, $(1, 1) \rightarrow (1, n) \rightarrow (n, n)$ is

$$n\mathcal{A}_{nn} - n\mathcal{A}_{n-1,n} + (n-1)\mathcal{A}_{n-1,n} - (n-1)\mathcal{A}_{n-2,n} + \dots + \mathcal{A}_{1n} - \mathcal{A}_{1,n-1} + P_{1,n-1}.$$

Again, by the monotonicity of the \mathcal{A} 's the second path is shorter than the first. ■

Let $F_j(r) = \sum_{t=1}^r f_{tj}$. Then for each j we have

$$\sum_{i=1}^n \{f_{ij}v(\mathcal{A}_{ij}|i, j) + (1 - F_j(i))[v(\mathcal{A}_{ij}|i, j) - v(\mathcal{A}_{ij}|i+1, j)]\} = \sum_{i=1}^n f_{ij}\mu(\mathcal{A}_{ij})$$

where

$$\mu(\mathcal{A}_{ij}) = v(\mathcal{A}_{ij}|i, j) + \frac{1 - F_j(i)}{f_{ij}}[v(\mathcal{A}_{ij}|i, j) - v(\mathcal{A}_{ij}|i+1, j)].$$

Following Myerson, we can think of this as the virtual valuation conditional on wanting to consume at most j units. The particular functional form of v allows us to write:

$$\mu(\mathcal{A}_{ij}) = \mathcal{A}_{ij} \left(i - \frac{1 - F_j(i)}{f_{ij}} \right).$$

Our optimization problem becomes:

$$\begin{aligned} Z_3 &= \max_{\{\mathbf{a}\}} \sum_i \sum_j f_{ij} \mathcal{A}_{ij} \left(i - \frac{1 - F_j(i)}{f_{ij}} \right) \\ &\text{s.t. } \mathcal{A}_{ij} \geq \mathcal{A}_{i'j'} \quad \forall (i, j) \geq (i', j') \\ \mathcal{A}_{ij} &= \sum_{t^{n-1}} \pi(t^{n-1}) \mathbf{a}_{ij}[(i, j), t^{n-1}] \quad \forall (i, j) \\ \sum_{i \in R} \sum_{j \in K} n n_{ij}(t) \mathbf{a}_{ij}[t] &\leq Q \quad \forall t \\ \mathbf{a}_{ij}[t] &\leq j \quad \forall i, j \quad \forall t \end{aligned}$$

Substituting out the \mathcal{A}_{ij} variables yields:

$$\begin{aligned} Z_3 &= \max_{\{\mathbf{a}\}} \sum_i \sum_j f_{ij} \sum_{t^{n-1}} \pi(t^{n-1}) \mathbf{a}_{ij}[(i, j), t^{n-1}] \left(i - \frac{1 - F_j(i)}{f_{ij}} \right) \\ \text{s.t. } \sum_{t^{n-1}} \pi(t^{n-1}) \mathbf{a}_{ij}[(i, j), t^{n-1}] &\geq \sum_{t^{n-1}} \pi(t^{n-1}) \mathbf{a}_{i'j'}[(i', j'), t^{n-1}] \quad \forall (i, j) \geq (i', j') \\ \sum_{i \in R} \sum_{j \in K} n n_{ij}(t) \mathbf{a}_{ij}[(i, j), t^{n-1}] &\leq Q \quad \forall t \\ \mathbf{a}_{ij}[t] &\leq j \quad \forall i, j \quad \forall t \end{aligned}$$

If we ignore the monotonicity condition $\sum_{t^{n-1}} Pr(t^{n-1}) \mathbf{a}_{ij}[(i, j), t^{n-1}] \geq \sum_{t^{n-1}} Pr(t^{n-1}) \mathbf{a}_{i'j'}[(i', j'), t^{n-1}]$, the optimization problem reduces to a collection of optimization problems one for each profile t :

$$\begin{aligned} Z^3(t) &= n \max_{\{\mathbf{a}\}} \sum_i \sum_j n_{ij}(t) \mathbf{a}_{ij}[t] \left(i - \frac{1 - F_j(i)}{f_{ij}} \right) \\ \text{s.t.} \quad & \sum_{i \in R} \sum_{j \in K} n n_{ij}(t) \mathbf{a}_{ij}[t] \leq Q \\ & \mathbf{a}_{ij}[t] \leq j \quad \forall i, j \end{aligned}$$

This is an instance of a continuous knapsack problem with upper bound constraints on the variables which is easy to solve. Basically, select the pair (i, j) which maximizes $i - \frac{1 - F_j(i)}{f_{ij}}$ and increase \mathbf{a}_{ij} units it reaches its upper bound or the supply is exhausted, whichever comes first. If the supply is not exhausted repeat.

If we assume a monotone hazard condition of the form:

$$i - \frac{1 - F_j(i)}{f_{ij}} \geq i' - \frac{1 - F_{j'}(i')}{f_{i'j'}} \quad \forall (i, j) \geq (i', j').$$

The resulting solution would satisfy the omitted monotonicity constraint.

6 Wilson's Case

One case where it is possible to find the optimal paths is in a discrete 2D analog of a continuous model first solved by Wilson (1993, Chapter 13). In Wilson's model customers are uniformly distributed on $\Omega = \{t \in R_+^2, t_1 + t_2 \leq 1\}$, with utility $v(q|t) = q \cdot t$, and the seller has the cost $C(q) = \frac{\|q\|^2}{2}$. The objective is to maximize the seller's profit in a direct mechanism,

$$\max_{q, P} \int_{\Omega} P(t) - C(q(t)) dt \quad (\text{OPT-W})$$

$$\text{s.t. } v(q(t)|t) - P(t) \leq v(q(s)|t) - P(s) \quad \forall t, s \in \Omega \quad (\text{IC})$$

The solution to Wilson's problem is given by

$$q^*(t) = \frac{1}{2} \max \left(0, 3 - \frac{1}{\|t\|^2} \right) t. \quad (23)$$

6.1 Discrete Approach to the Problem

Let's solve the [OPT-W] problem in discrete polar coordinates using the network representation.

Consider a discrete grid in polar coordinates (r, φ) , i.e.

$$\begin{aligned} t_1 &= r \cos \varphi, \\ t_2 &= r \sin \varphi. \end{aligned}$$

where $r \in \{r_1, \dots, r_n\}$, where $r_i = \frac{i}{n}$ and $\varphi \in \{0, \frac{\pi}{2k}, \frac{2\pi}{2k}, \dots, \frac{\pi}{2}\}$. Consider the direct mechanism approach with the allocation schedule given by

$$\begin{aligned} q_1(r, \varphi) &= R(r, \varphi) \cos \theta(r, \varphi), \\ q_2(r, \varphi) &= R(r, \varphi) \sin \theta(r, \varphi). \end{aligned}$$

The IC constraints then are

$$\begin{aligned} &R(r, \varphi) \cos \theta(r, \varphi) r \cos \varphi + R(r, \varphi) \sin \theta(r, \varphi) r \sin \varphi - P(r, \varphi) \geq \\ &\geq R(r', \varphi') \cos \theta(r', \varphi') r \cos \varphi + R(r', \varphi') \sin \theta(r', \varphi') r \sin \varphi - P(r', \varphi'). \end{aligned}$$

The cost function is given by

$$C(q) = \frac{R(r, \varphi)^2}{2}.$$

Our approach will be to conjecture that the optimal paths must be radial and then compute an optimal allocation for such a conjecture. This amounts to relaxing some of the IC constraints. We complete the argument by showing that the solution found satisfies the IC constraints that were relaxed.

Lemma 3 *If a payment $P(r_i, \varphi)$ is determined by a radial path $(0, \varphi) \longrightarrow (r_1, \varphi) \longrightarrow \dots \longrightarrow (r_i, \varphi)$, then the optimal allocations are given by*

$$\begin{aligned} q_1(r_i, \varphi) &= R(r_i, \varphi) \cos \varphi, \\ q_2(r_i, \varphi) &= R(r_i, \varphi) \sin \varphi, \end{aligned}$$

and the profit-maximizing payment $P(r_i, \varphi)$ is given by

$$P(r_i, \varphi) = \sum_{j=1}^i [r_j R(r_j, \varphi) - r_j R(r_{j-1}, \varphi)]. \quad (24)$$

Proof. The proof is done by induction in $r_i \in \{r_1, \dots, r_{n+1}\}$.

First, consider the case of $i = 1$, and $\varphi_j \in \{0, \frac{\pi}{2k}, \frac{2\pi}{2k}, \dots, \frac{\pi}{2}\}$.

If the payment is set through a radial path, i.e. $(0, \varphi_j) \longrightarrow (r_1, \varphi_j)$, then

$$P(r_1, \varphi_j) = R(r_1, \varphi_j) \cos \theta(r_1, \varphi_j) (r_1 \cos \varphi_j) + R(r_1, \varphi_j) \sin \theta(r_1, \varphi_j) (r_1 \sin \varphi_j),$$

and the profit is

$$\Pi_j = R(r_1, \varphi_j) \cos \theta(r_1, \varphi_j) (r_1 \cos \varphi_j) + R(r_1, \varphi_j) \sin \theta(r_1, \varphi_j) (r_1 \sin \varphi_j) - \frac{1}{2}R^2(r_1, \varphi_j).$$

Notice that the above profit along the path is maximized in θ when $\theta(r, \varphi_j) = \varphi_j$ (indeed, it does not affect the cost, while maximizing the revenue), hence

$$\begin{aligned} q_1(r_1, \varphi_j) &= R(r_1, \varphi_j) \cos \varphi_j, \\ q_2(r_1, \varphi_j) &= R(r_1, \varphi_j) \sin \varphi_j, \\ \Pi_j &= r_1 R(r_1, \varphi_j) - \frac{1}{2}R^2(r_1, \varphi_j), \end{aligned}$$

and

$$P(r_1, \varphi_j) = r_1 R(r_1, \varphi_j).$$

Now let's do the transition from i to $i + 1$. Assuming that

$$\begin{aligned} q_1(r_i, \varphi_j) &= R(r_i, \varphi_j) \cos \varphi_j, \\ q_2(r_i, \varphi_j) &= R(r_i, \varphi_j) \sin \varphi_j, \end{aligned}$$

$$P(r_i, \varphi) = \sum_{j=1}^i r_j R(r_j, \varphi) - r_j R(r_{j-1}, \varphi),$$

and that $P(r_{i+1}, \varphi_j)$ is determined by the path $(0, \varphi_j) \longrightarrow \dots \longrightarrow (r_i, \varphi_j) \longrightarrow (r_{i+1}, \varphi_j)$, we conclude

$$\begin{aligned} P(r_{i+1}, \varphi_j) &= R(r_{i+1}, \varphi_j) \cos \theta(r_{i+1}, \varphi_j) (r_{i+1} \cos \varphi_j) + R(r_{i+1}, \varphi_j) \sin \theta(r_{i+1}, \varphi_j) (r_{i+1} \sin \varphi_j) - \\ &\quad - r_{i+1} R(r_i, \varphi_j) + P(r_i, \varphi_j), \end{aligned}$$

and the profit along the path is

$$\begin{aligned} \Pi_j &= R(r_{i+1}, \varphi_j) \cos \theta(r_{i+1}, \varphi_j) (r_{i+1} \cos \varphi_j) + R(r_{i+1}, \varphi_j) \sin \theta(r_{i+1}, \varphi_j) (r_{i+1} \sin \varphi_j) - \\ &\quad - r_{i+1} R(r_i, \varphi_j) + P(r_i, \varphi_j) - \frac{1}{2}R^2(r_{i+1}, \varphi_j) + \end{aligned}$$

$$+ \sum_{l=0}^i \left[P(r_l, \varphi_j) - \frac{1}{2} R^2(r_l, \varphi_j) \right]$$

By the same argument as in the case of r_1 , we conclude that the above profit is maximized when $\theta(r_{i+1}, \varphi_j) = \varphi_j$, hence

$$\begin{aligned} q_1(r_{i+1}, \varphi_j) &= R(r_{i+1}, \varphi_j) \cos \varphi_j, \\ q_2(r_{i+1}, \varphi_j) &= R(r_{i+1}, \varphi_j) \sin \varphi_j, \end{aligned}$$

and

$$P(r_{i+1}, \varphi) = \sum_{j=1}^{i+1} r_j R(r_j, \varphi) - r_j R(r_{j-1}, \varphi). \quad \blacksquare$$

Lemma 4 *If all profit-maximizing payments $P(r_i, \varphi)$ are determined by radial paths $(0, \varphi) \longrightarrow (r_1, \varphi) \longrightarrow \dots \longrightarrow (r_i, \varphi)$, then optimal allocations are given by*

$$q_1(r_i, \varphi) = R(r_i) \cos \varphi, \quad (25)$$

$$q_2(r_i, \varphi) = R(r_i) \sin \varphi, \quad (26)$$

and payments $P(r_i, \varphi)$ do not depend on φ , i.e.

$$P(r_i, \varphi) = P(r_i) = \sum_{j=1}^i [r_j R(r_j) - r_j R(r_{j-1})]. \quad (27)$$

Proof. The proof is done by induction in $r_i \in \{r_1, \dots, r_{n+1}\}$.

First, consider the case of $i = 1$, and $\varphi \in \{0, \frac{\pi}{2k}, \frac{2\pi}{2k}, \dots, \frac{\pi}{2}\}$.

If the payments are set through radial paths, i.e. $(0, \varphi) \longrightarrow (r_1, \varphi)$, then Lemma 3 gives

$$q_1(r_1, \varphi) = R(r_1, \varphi) \cos \varphi,$$

$$q_2(r_1, \varphi) = R(r_1, \varphi) \sin \varphi,$$

$$P(r_1, \varphi) = r_1 R(r_1, \varphi),$$

and the profit is

$$\Pi = \sum_{j=0}^k r_1 R(r_1, \varphi_j) - \frac{1}{2} \sum_{j=0}^k R^2(r_1, \varphi_j).$$

Notice that the above profit is maximized in $R(r_1, \varphi)$ when

$$R(r_1, \varphi_j) = R(r_1) = \frac{1}{k+1} \sum_{j=1}^k R(r_1, \varphi_j), \quad (28)$$

since the allocation rule determined by (28) does not affect the revenue, while minimizing the cost..Hence

$$\begin{aligned} q_1(r_1, \varphi_j) &= R(r_1) \cos \varphi_j, \\ q_2(r_1, \varphi_j) &= R(r_1) \sin \varphi_j, \\ \Pi &= \sum_{j=0}^k r_1 R(r_1) - \frac{1}{2} \sum_{j=0}^k R^2(r_1), \end{aligned}$$

and

$$P(r_1, \varphi) = r_1 R(r_1).$$

Now let's do the transition from i to $i + 1$. By the assumption of induction we have that

$$\begin{aligned} q_1(r_i, \varphi_j) &= R(r_i) \cos \varphi_j, \\ q_2(r_i, \varphi_j) &= R(r_i) \sin \varphi_j, \\ P(r_i, \varphi) &= \sum_{j=1}^i r_j R(r_j) - r_j R(r_{j-1}). \end{aligned}$$

The assumption that $P(r_{i+1}, \varphi)$ is determined by the path $(0, \varphi) \longrightarrow \dots \longrightarrow (r_i, \varphi) \longrightarrow (r_{i+1}, \varphi)$, along with Lemma 3 give

$$\begin{aligned} q_1(r_{i+1}, \varphi) &= R(r_{i+1}, \varphi) \cos \varphi, \\ q_2(r_{i+1}, \varphi) &= R(r_{i+1}, \varphi) \sin \varphi, \\ P(r_{i+1}, \varphi_i) &= r_{i+1} R(r_{i+1}, \varphi_i) - r_{i+1} R(r_i) + P(r_i), \end{aligned}$$

and the profit is

$$\begin{aligned} \Pi &= \sum_{l=0}^i \left[\sum_{j=0}^k P(r_l, \varphi) - \frac{1}{2} \sum_{j=0}^k R^2(r_l, \varphi_j) \right] + \\ &+ \sum_{j=0}^k [r_{i+1} R(r_{i+1}, \varphi_j) - r_{i+1} R(r_i, \varphi_j) + P(r_i, \varphi_j)] - \frac{1}{2} \sum_{j=0}^k R^2(r_{i+1}, \varphi_j). \end{aligned}$$

By the same argument as in the case of r_1 , we conclude that the above profit is maximized when

$$R(r_{i+1}, \varphi_j) = R(r_{i+1}) = \frac{1}{k+1} \sum_{j=1}^k R(r_{i+1}, \varphi_j),$$

hence

$$\begin{aligned} q_1(r_{i+1}, \varphi_j) &= R(r_{i+1}) \cos \varphi_j, \\ q_2(r_{i+1}, \varphi_j) &= R(r_{i+1}) \sin \varphi_j, \end{aligned}$$

and

$$P(r_i, \varphi) = P(r_i) = \sum_{j=1}^i [r_j R(r_j) - r_j R(r_{j-1})]. \quad \blacksquare$$

Lemma 5 *All profit-maximizing payments $P(r_i, \varphi)$ are determined by radial paths*

$$(0, \varphi) \longrightarrow (r_1, \varphi) \longrightarrow \dots \longrightarrow (r_i, \varphi).$$

Proof. The proof is done by induction in r_n .

First, consider the case of $i = 1$, and $\varphi \in \{0, \frac{\pi}{2k}, \frac{2\pi}{2k}, \dots, \frac{\pi}{2}\}$. Denote payments that are determined by radial paths $(0, \varphi) \longrightarrow (r_1, \varphi)$ as $P_r(r_1, \varphi)$, and payments that are determined by nonradial paths $(0, \varphi') \longrightarrow (r_1, \varphi') \longrightarrow (r_1, \varphi)$ as $P_{nr}(r_1, \varphi)$. Then

$$P_r(r_1, \varphi) = R(r_1, \varphi) \cos \theta(r_1, \varphi) (r_1 \cos \varphi) + R(r_1, \varphi) \sin \theta(r_1, \varphi) (r_1 \sin \varphi), \quad (29)$$

and

$$\begin{aligned} P_{nr}(r_1, \varphi) &= R(r_1, \varphi) \cos \theta(r_1, \varphi) (r_1 \cos \varphi) + R(r_1, \varphi) \sin \theta(r_1, \varphi) (r_1 \sin \varphi) - \\ &- R(r_1, \varphi') \cos \theta(r_1, \varphi') (r_1 \cos \varphi) - R(r_1, \varphi') \sin \theta(r_1, \varphi') (r_1 \sin \varphi) + P_r(r_1, \varphi'). \end{aligned}$$

Lemma 3 gives that $P_r(r_1, \varphi') = r_1 R(r_1, \varphi')$, hence

$$\begin{aligned} P_{nr}(r_1, \varphi) &= R(r_1, \varphi) \cos \theta(r_1, \varphi) (r_1 \cos \varphi) + R(r_1, \varphi) \sin \theta(r_1, \varphi) (r_1 \sin \varphi) - \\ &- R(r_1, \varphi') \cos \theta(r_1, \varphi') (r_1 \cos \varphi) - R(r_1, \varphi') \sin \theta(r_1, \varphi') (r_1 \sin \varphi) + r_1 R(r_1, \varphi'). \end{aligned} \quad (30)$$

Combining (29) and (30) we obtain

$$P_{nr}(r_1, \varphi) = P_r(r_1, \varphi) + r_1 R(r_1, \varphi') (1 - \cos \theta(r_1, \varphi') \cos \varphi - \sin \theta(r_1, \varphi') \sin \varphi).$$

Finally, since $\cos \theta \cos \varphi + \sin \theta \sin \varphi < 1$ for $\forall \theta \neq \varphi$, we conclude that

$$P_{nr}(r_1, \varphi) \geq P_r(r_1, \varphi),$$

which proves that the radial path is the shorter one, and since payments are determined by shortest paths, profit-maximizing payments $P(r_1, \varphi)$ are determined by radial paths.

Now let's do the transition from i to $i + 1$. Assuming that $P(r_i, \varphi)$ are determined by radial paths by Lemma 4 we have

$$q_1(r_i, \varphi_j) = R(r_i) \cos \varphi_j, \quad (31)$$

$$q_2(r_i, \varphi_j) = R(r_i) \sin \varphi_j, \quad (32)$$

$$P(r_i, \varphi) = P(r_i) = \sum_{j=1}^i [r_j R(r_j) - r_j R(r_{j-1})]. \quad (33)$$

We now need to show that the payment $P_r(r_{i+1}, \varphi)$, determined by the radial path $(r_i, \varphi) \rightarrow (r_{i+1}, \varphi)$ is smaller than payments $P_{nr1}(r_{i+1}, \varphi)$ and $P_{nr2}(r_{i+1}, \varphi)$, that are determined by paths $(r_i, \varphi') \rightarrow (r_{i+1}, \varphi') \rightarrow (r_{i+1}, \varphi)$ and $(r_i, \varphi') \rightarrow (r_{i+1}, \varphi)$ respectively. Then using (31), (32), and (33), and without assuming anything about allocations at (r_{i+1}, φ) , we get

$$\begin{aligned} P_r(r_{i+1}, \varphi) &= R(r_{i+1}, \varphi) \cos \theta(r_{i+1}, \varphi) (r_{i+1} \cos \varphi) + R(r_{i+1}, \varphi) \sin \theta(r_{i+1}, \varphi) (r_{i+1} \sin \varphi) \\ &\quad - r_{i+1} R(r_i) + P_r(r_i). \end{aligned} \quad (34)$$

For the $P_{nr1}(r_{i+1}, \varphi)$ we have

$$\begin{aligned} P_{nr1}(r_{i+1}, \varphi) &= R(r_{i+1}, \varphi) \cos \theta(r_{i+1}, \varphi) (r_{i+1} \cos \varphi) + R(r_{i+1}, \varphi) \sin \theta(r_{i+1}, \varphi) (r_{i+1} \sin \varphi) - \\ &\quad - R(r_{i+1}, \varphi') \cos \theta(r_{i+1}, \varphi') (r_{i+1} \cos \varphi) - R(r_{i+1}, \varphi') \sin \theta(r_{i+1}, \varphi') (r_{i+1} \sin \varphi) + P_r(r_{i+1}, \varphi'). \end{aligned} \quad (35)$$

Now notice that for the $P_{nr1}(r_{i+1}, \varphi)$ to be determined by the shortest path, $P_r(r_{i+1}, \varphi')$ must be determined by the radial path, hence by Lemma 3

$$P_r(r_{i+1}, \varphi') = r_{i+1} R(r_{i+1}, \varphi') - r_{i+1} R(r_i) + P_r(r_i). \quad (36)$$

Combining (35) and (36) we obtain

$$\begin{aligned} P_{nr1}(r_{i+1}, \varphi) &= R(r_{i+1}, \varphi) \cos \theta(r_{i+1}, \varphi) (r_{i+1} \cos \varphi) + R(r_{i+1}, \varphi) \sin \theta(r_{i+1}, \varphi) (r_{i+1} \sin \varphi) - \\ &\quad - R(r_{i+1}, \varphi') \cos \theta(r_{i+1}, \varphi') (r_{i+1} \cos \varphi) - R(r_{i+1}, \varphi') \sin \theta(r_{i+1}, \varphi') (r_{i+1} \sin \varphi) + \\ &\quad + r_{i+1} R(r_{i+1}, \varphi') - r_{i+1} R(r_i) + P_r(r_i). \end{aligned} \quad (37)$$

Finally, (34) and (37) give

$$P_{nr1}(r_{i+1}, \varphi) = P_r(r_{i+1}, \varphi) + r_{i+1} R(r_{i+1}, \varphi') (1 - \cos \theta(r_{i+1}, \varphi') \cos \varphi - \sin \theta(r_{i+1}, \varphi') \sin \varphi),$$

and since $\cos \theta \cos \varphi + \sin \theta \sin \varphi < 1$ for $\forall \theta \neq \varphi$, we conclude that

$$P_{nr1}(r_{i+1}, \varphi) \geq P_r(r_{i+1}, \varphi). \quad (38)$$

For the $P_{nr2}(r_{i+1}, \varphi)$ we have

$$\begin{aligned} P_{nr1}(r_{i+1}, \varphi) &= R(r_{i+1}, \varphi) \cos \theta(r_{i+1}, \varphi) (r_{i+1} \cos \varphi) + R(r_{i+1}, \varphi) \sin \theta(r_{i+1}, \varphi) (r_{i+1} \sin \varphi) - \\ &\quad - R(r_i, \varphi') \cos \theta(r_i, \varphi') (r_{i+1} \cos \varphi) - R(r_i, \varphi') \sin \theta(r_i, \varphi') (r_{i+1} \sin \varphi) + P_r(r_i, \varphi'). \end{aligned} \quad (39)$$

Then using (31), (32), and (33), and without assuming anything about allocations at (r_{i+1}, φ) , we get

$$\begin{aligned} P_{nr1}(r_{i+1}, \varphi) &= R(r_{i+1}, \varphi) \cos \theta(r_{i+1}, \varphi) (r_{i+1} \cos \varphi) + R(r_{i+1}, \varphi) \sin \theta(r_{i+1}, \varphi) (r_{i+1} \sin \varphi) - \\ &\quad - r_{i+1} R(r_i) + P_r(r_i). \end{aligned} \quad (40)$$

Finally, (34) and (40) give

$$P_{nr1}(r_{i+1}, \varphi) = P_{nr1}(r_{i+1}, \varphi). \quad (41)$$

This inequality (38) and equality (40) prove that the radial path is the shortest one, and since payments are determined by shortest paths, all profit-maximizing payments $P(r_{i+1}, \varphi)$ are determined by radial paths. ■

Theorem 10 *Optimal allocations are given by*

$$\begin{aligned} q_1(r_i, \varphi) &= R(r_i) \cos \varphi, \\ q_2(r_i, \varphi) &= R(r_i) \sin \varphi, \end{aligned}$$

and payments $P(r_i, \varphi)$ do not depend on φ , i.e.

$$P(r_i, \varphi) = P(r_i) = \sum_{j=1}^i [r_j R(r_j) - r_j R(r_{j-1})].$$

Proof. Follows from Lemmas 4 and 5. ■

Theorem 10 allows us to successfully solve Wilson's optimization problem in polar coordinates. The uniform probability density function changes from $f(t_1, t_2) = \frac{4}{\pi}$ to $f(r, \varphi) = 2r$ in continuous case, and to $f(i) = \frac{2i}{n(n+1)}$ and $F(i) = \frac{i(i+1)}{n(n+1)}$ in discrete case after the switch to the polar coordinates.

The problem [OPT-W] is now reduced to a standard one-dimensional profit maximization problem, which can be successfully solve by following Myerson's (1981) approach in a discrete case. Recall the general expression for the virtual valuation:

$$\mu(\mathcal{A}_i) = v(\mathcal{A}_i|i) - \frac{1 - F(i)}{f_i} [v(\mathcal{A}_i|i + 1) - v(\mathcal{A}_i|i)],$$

which in our case looks like

$$\mu(R(i)) = R(i) \frac{i}{n} - \frac{1 - F(i)}{f(i)} \left[R(i) \frac{i+1}{n} - R(i) \frac{i}{n} \right],$$

$$\mu(R(i)) = R(i) \left(\frac{i}{n} - \frac{1 - F(i)}{nf(i)} \right).$$

Hence the profit maximizing problem could be written as

$$\Pi = \max_{\{R(i)\}_{i=1}^n} \sum_{i=1}^n f(i) \left[R(i) \left(\frac{i}{n} - \frac{1 - F(i)}{nf(i)} \right) - C(R(i)) \right],$$

and can be solved type by type in the following formulation:

$$\begin{aligned} \max_{R(i)} R(i) \left(\frac{i}{n} - \frac{1 - F(i)}{nf(i)} \right) - C(R(i)), \\ \max_{R(i)} R(i) \left(\frac{i}{n} - \frac{1 - \frac{i(i+1)}{n(n+1)}}{\frac{2i}{(n+1)}} \right) - \frac{R^2(i)}{2}. \end{aligned} \quad (\text{OPT-W}')$$

Solving [OPT-W'] we obtain the expression for the optimal choice of $R(i)$:

$$\begin{aligned} R(i) &= \max \left(0, \frac{2i^2 + i(i+1) - n(n+1)}{2in} \right), \\ R(i) &= \frac{n+1}{2i} \max \left(0, \frac{2i}{n+1} r_i + \frac{i+1}{n+1} r_i - 1 \right). \end{aligned} \quad (42)$$

The expression (42) is the exact discrete analog of Wilson's continuous solution to [OPT-W] given by (23).

7 Conclusion

In this paper we study auctions in a multi-dimensional type space with discrete types. This has the advantage of transparency of analysis, and it also allows one to approach the problem from an intuitive graph theoretic perspective. This approach highlights the connections between optimal

mechanism design and the problem of finding a shortest path in a lattice, as well as linear programming. It clarifies the nature of the difficulties inherent in the multi-dimensional optimal auction design, and makes clear which cases are solvable and which are not.

We offer a graph theoretic perspective on existing results, such as Myerson's (1981) one-dimensional optimal auction design problem along with the ironing procedure, and Wilson's (1993) problem for a monopolist to design optimal quantity/allocation schedules for two-dimensional consumer types. Our approach also provides new results for two-dimensional auctions with capacitated bidders under the no-inflation assumption.

References

- [1] Ahuja, R., Magananti, T. and Orlin, J. (1993) *Network Flows*, New Jersey, Prentice Hall.
- [2] Krishna, V. and Perry, M. (2000), 'Efficient Mechanism Design,' *working paper*, Pennsylvania State University and The Hebrew University of Jerusalem.
- [3] Maskin, E. S.(2002), 'How to Reduce Greenhouse Gas Emissions: An Application of Auction Theory,' *Northwestern University - Nancy Schwartz Memorial Lecture*.
- [4] Myerson, R. (1981), 'Optimal Auction Design,' *Mathematics of Operations Research*, 6: 58-73.
- [5] Rochet, J. C. (1987), 'A Necessary and Sufficient Condition for Rationalizability in a Quasi-Linear Context,' *Journal of Mathematical Economics*, 16: 191-200.
- [6] Rochet, J. C. and Choné, P. (1998), 'Ironing, Sweeping, and Multidimensional Screening,' *Econometrica*, 66: 783-826.
- [7] Rochet, J. C. and Stole, L. A. (2003), 'The Economics of Multidimensional Screening,' in *Advances in Economics and Econometrics: Theory and Applications, Eighth World Congress*, ed. M. Dewatripont, L. P. Hansen and S. J. Turnovsky, Cambridge: Cambridge University Press.
- [8] Ronen, A. and Saberi, A. (2002), 'Optimal Auctions are Hard,' in *Proceedings of the 43rd Annual IEEE Symposium on Foundations of Computer Science*, Vancouver, Canada.
- [9] Wilson, R. (1993), *Non Linear Pricing*, Oxford: Oxford University Press.